



## Shearing Technology for Marine Drilling

# Shearing Technology for Marine Drilling

A critical component of any drilling program is the ability to shear tubular and seal the well to prevent blowouts. As tubular grades have evolved to greater sizes and strengths, some components of the drill string, such as tool joints and drill collars, have been considered non-shearable. A perpetual industry challenge is the development of technology that meets increasing shearing demands, while also meeting existing system concerns such as space constraints, handling equipment capacities, and wellhead strengths.

As a leader in shearing innovation, our shearing ram and bonnet technology have been expertly designed to meet shearing requirements. With continued focus on technology development, Cameron is building on our current shearing and sealing technologies to offer a shear ram that cuts off-center tool joints and seals the well.

# Shearing Rams

The BroadShear\* off-center, tool joint shear ram is the industry's only ram to shear what was previously considered non-shearable, including the hard banding on tool joints.

## Key Benefits:

1. The ability to shear hard banding on tool joints
2. Reliable off-center shearing

In a series of rigorous tests, a single set of the new BroadShear rams successfully sheared various drill string components seven times. These tests included through the pin/box, through the hard banding, as well as two off-center tests.

In a separate test, another set of the rams successfully sheared off-center in a demonstration for the Bureau of Safety and Environmental Enforcement (BSEE).



*Shear through the pin/box*



*Shear through the hard banding*

### Specifications:

Dimensions, in	22 w x 11½ h x 25 l (each)
Weight, lb [kg]	1,152 [522] per set
Third-party qualification	DNV and ABS

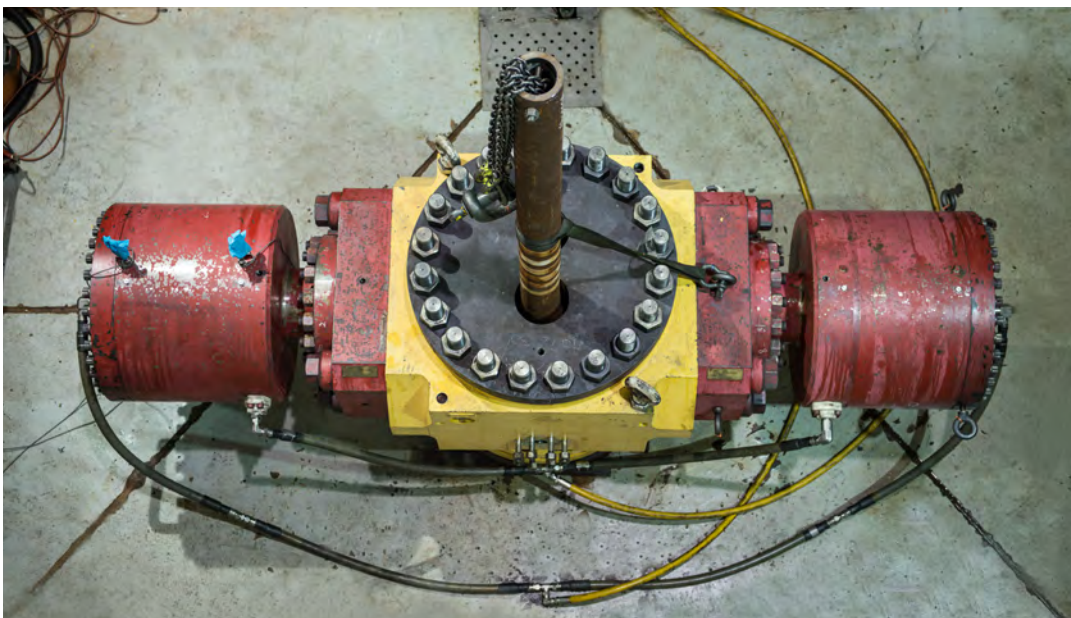

*Off-center shear test setup*

# Shearing and Sealing Rams

Field-proven CDVS-II shearing and sealing ram can shear and seal on braided cable, coiled tubing, strong pipe, and casing.

## Key Benefits:

1. The ability to shear and seal 10¾ in. OD 60.7 ppf C110 casing
2. Reliable sealing elastomers and operation

The CDVS-II rams have been operating in the field since 2014.

The CDVS-II rams have a unique foldover pocket for the sheared lower section. This allows the rams to close and seal.

Our proprietary elastomer compound ensures a reliable seal. All Cameron elastomers are manufactured with strict quality control adherence and traceability.

---

### Specifications:

Temperature rating	30 degF to 350 degF
Dimensions, in	22 w x 11½ h x 17½ l (each)
Weight, lb [kg]	1,176 [533] per set
Third-party qualification	DNV and ABS

---

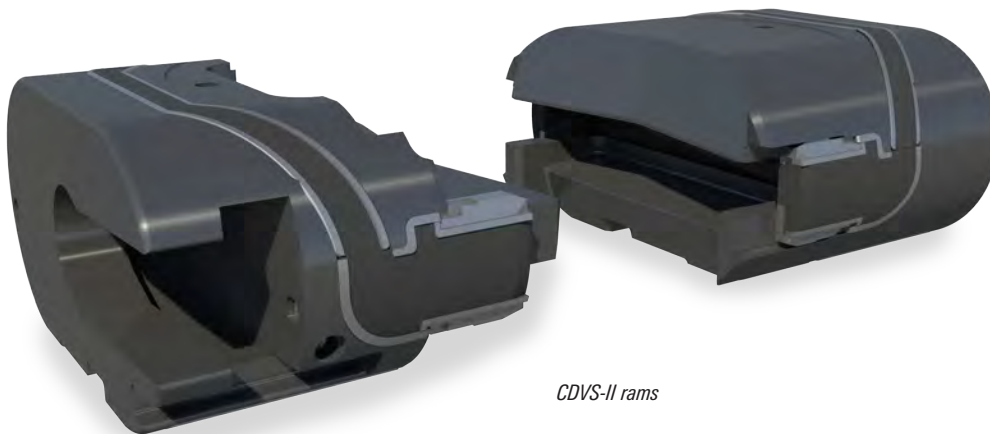

*CDVS-II rams*

# BOP Bonnets

The bonnets that supply the force for the rams to shear and seal are a critical component of shearing technology. Cameron carefully designs and manufactures BOP bonnets that adhere to both space and pressure requirements.

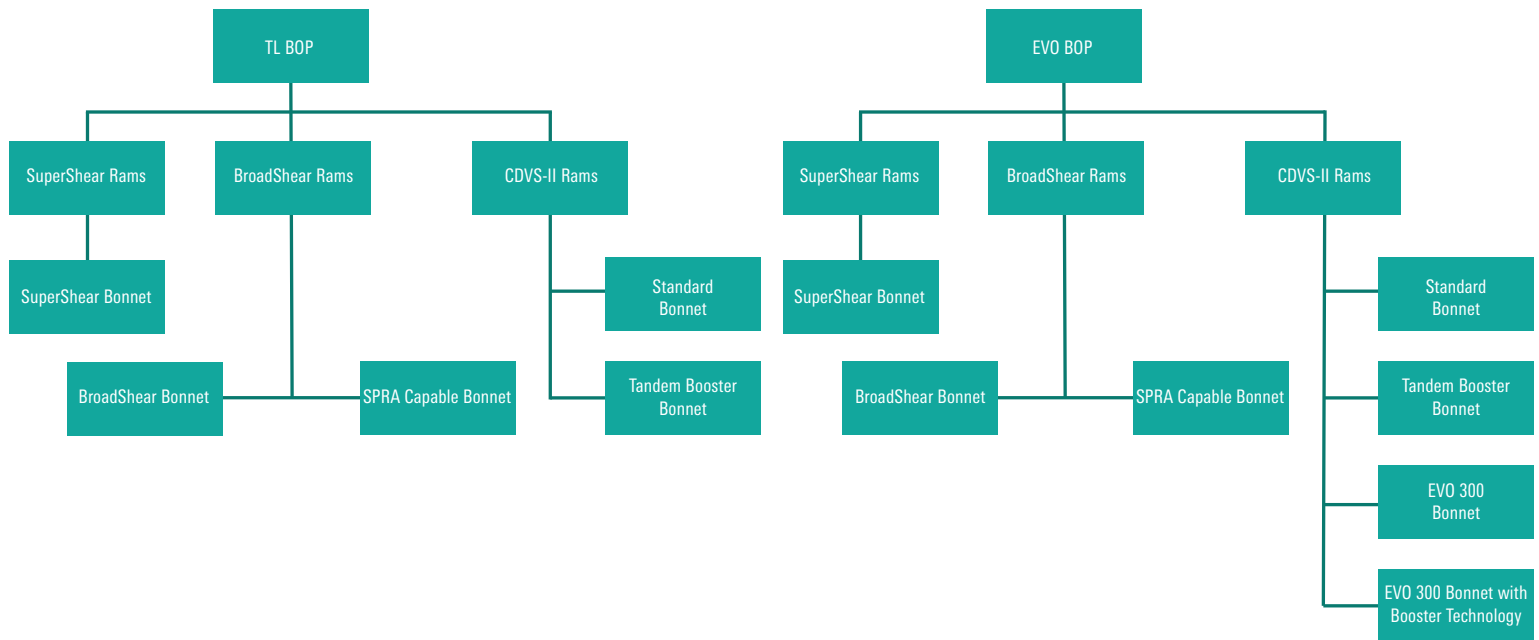

The EVO 300\* bonnet assembly is the newest bonnet design for the EVO\* BOP and increases closing force by 54% over the previous EVO standard bonnet design. This becomes an attractive option for jackup stacks where limited footprint is desired. It also offers a ShearBooster\* option that can provide 10% greater force than existing tandem boosters.

Cameron also offers a SPRA\* seawater pressure reduction assembly technology. It uses subsea water pressure to increase the efficiency of the BOP's hydraulic system. The SPRA assembly increases the BOP's shearing and sealing capabilities while reducing the number of subsea accumulator bottles needed.

# Shearing Technology for Marine Drilling

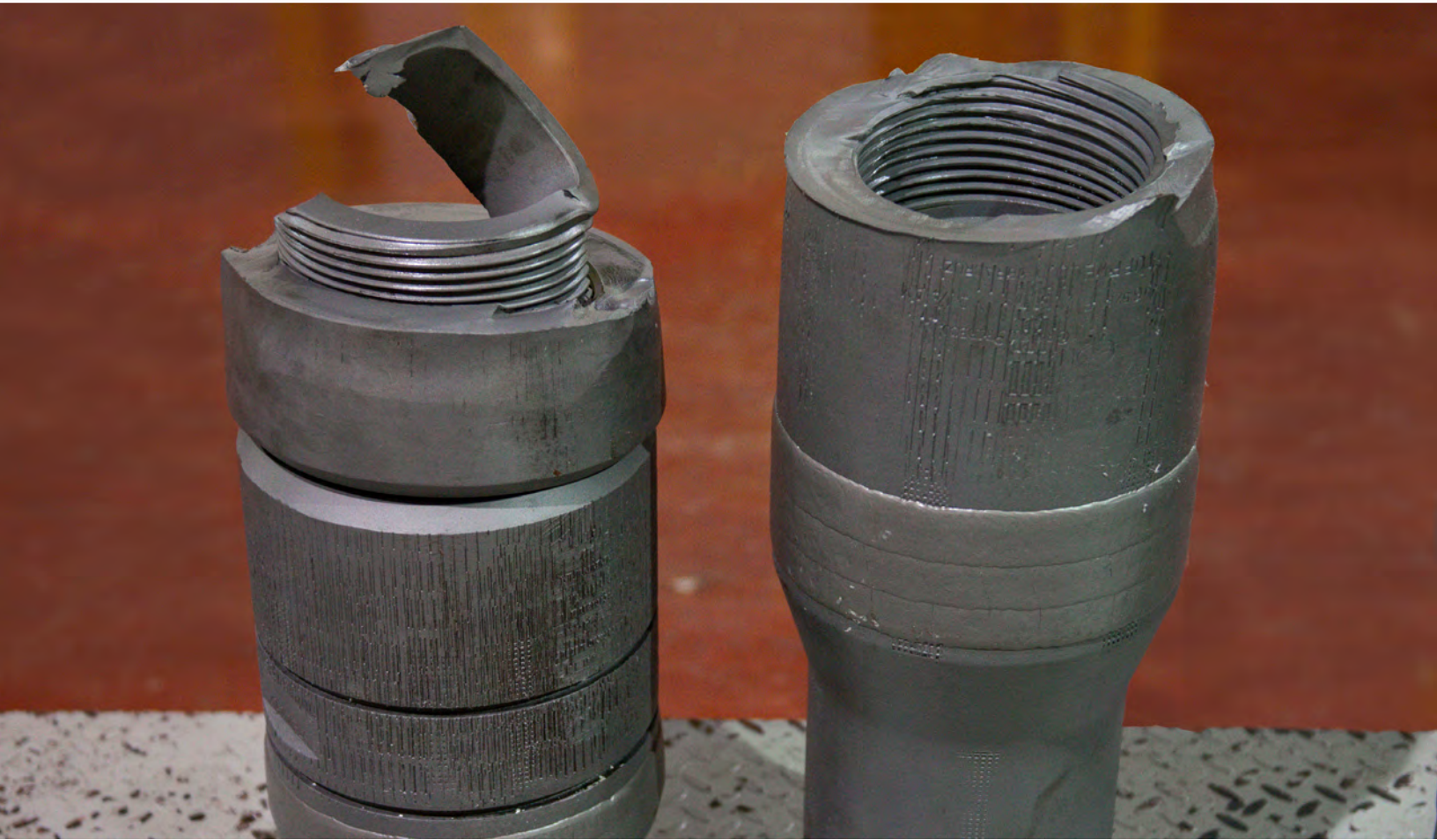

[cameron.slb.com](http://cameron.slb.com)

\*Mark of Schlumberger  
Other company, product, and service names  
are the properties of their respective owners.  
Copyright © 2016 Schlumberger. All rights reserved. DRL-1109

 **CAMERON**  
A Schlumberger Company