

# Solid Control, Cuttings Management and Fluids Processing

Drilling Environmental Solutions

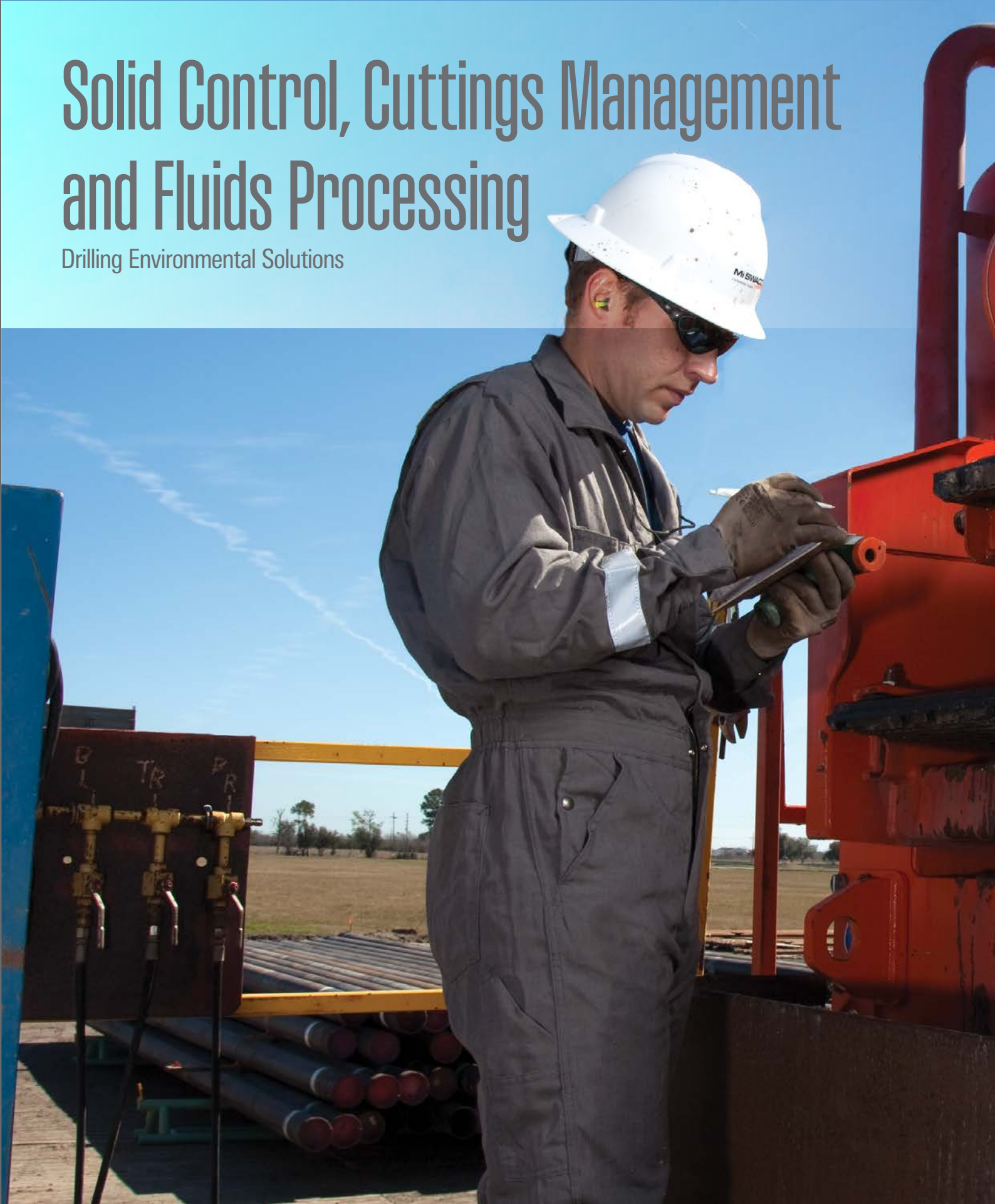



“Our Company is committed to continuous improvement of its global health, safety and environmental processes while supplying high-quality, environmentally responsible products and services to our customers.”





<b>Overview</b>	<b>4</b>
<b>Solids Control Systems and Products</b>	
<b>Shakers</b>	
MONGOOSE PRO Shale Shaker	8
MEERKAT PT Shale Shaker	12
MD-2 Dual-Deck Shale Shaker	16
MD-3 Triple-Deck Shale Shaker	20
Vibratory Systems Analysis Testing (VSAT) Program	24
<b>Mud Cleaners</b>	
High-Volume Mud Cleaners	26
<b>Oilfield Screens</b>	
DURAFLO Oilfield Screens	28
DURAFLO Composite OEM and Replacement Screens	31
M-I SWACO Commodity Screens Portfolio	36
<b>Centrifuges</b>	
CD-500 HV Centrifuge	38
518 HV Centrifuge	41
CD 250 Centrifuge	45
414 Centrifuge	47
Centrifuge Rotating Assemblies	49
<b>Dewatering</b>	<b>50</b>
<b>OPTM-IZER</b>	<b>51</b>

# Table of Contents

## Cuttings Management Systems and Products

### Cuttings Collection and Transportation

CLEANCUT Cuttings Collection and Transportation System 52

VACUUM COLLECTION SYSTEM (VCS) 53

### Cuttings Treatment

Cuttings Dryer (VERTI-G) 56

THERMAL DESORPTION: HAMMERMILL Onshore 61

THERMAL DESORPTION: HAMMERMILL Offshore 62

THERMAL PHASE SEPARATION (TPS) 63

Cuttings Re-Injection (CRI) 64

## Fluids Processing Systems and Products

DRILLING FLUID TEMPERATURE CONTROL SYSTEM 65

AUTOMATIC TANK CLEANING (ATC) 66

AUTOMATIC TANK CLEANING LITE (ATC LITE) 67

MULTI-PHASE CLARIFIER (MPC) 68

ENVIROUNIT 69

PRESSURE AND FLUID MANAGEMENT SYSTEM (PFMS) 70

## Pressure Control Systems and Products

CARBONTRACKER 71

### D-GASSERS

CD-1400 CENTRIFUGAL D-GASSER 72

COMPACT VACUUM D-GASSER 73

HORIZONTAL VACUUM D-GASSER 74

### Separators

MUD/GAS SEPARATOR 75

SUPER MUD/GAS SEPARATOR (SMGS) 76

### Drilling Chokes

AUTOCHOKE 77

LOW PRESSURE AUTOCHOKE CONSOLE (LPAC) 78

ECHOKE 79

SUPERCHOKE 80

VERSA-CHOKE 81

CHOKE MANIFOLD 82

## Rig-Equipment Engineering

Integrated Package Delivery 83

# Solutions for you and your well



## Solids Controls, Cuttings Management and Fluids Processing

- Solids Control
  - Shakers / Screens
  - Centrifuges / Pumps
  - Agitators
  - Conveyors
  - D-Silters and D-Sanders
  - Flow Dividers
  - Gumbo Chains
  - Shaker Vacuum Systems
  - Dryers
  - Dewatering
  - RHE-USE
  - Intelligent Fluid Monitoring
- Cuttings Management
  - CLEANCUT
  - CLEANBULK
  - Vacuum Technologies
  - Thermal Desorption Technologies
  - Cuttings Re-Injection (CRI)
- Fluids Processing
  - AUTOMATIC TANK CLEANING
  - ENVIROUNIT
  - Mixing Technologies
  - HI-SIDE / HI-RIDE
  - PFMS
  - Crossflow Filtration Units
  - Mud Coolers
  - CRI Assurance

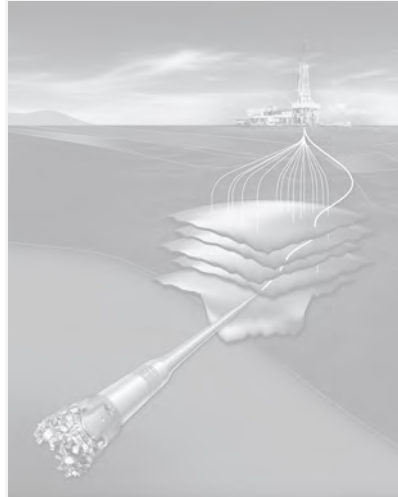

## Drilling Fluid Systems and Products

- Wellsite and project engineering
- Simulation software
- Drilling-fluid systems and additives
- ALPINE SPECIALTY CHEMICALS<sup>+</sup> Federal<sup>+</sup> Wholesale
- HDD Mining and Waterwell
- Technical support

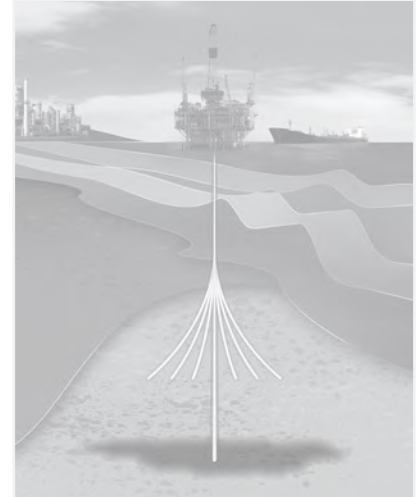

## Production Technologies

- Specialty production chemicals
- Chemical management
- Drag reduction
- H<sub>2</sub>S treatment
- Descaling, decontamination and decommissioning
- Commodity and utility chemicals
- Produced water treatment
- Production Waste Management

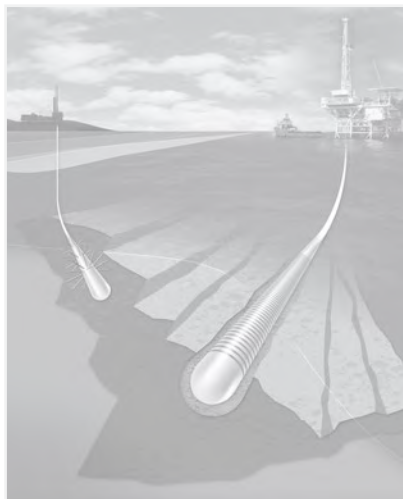

### Completion Fluid Systems and Products, Reservoir Drill-In Fluids, Breakers, Filtration and Specialized Tools

- Engineering/simulation software
- Reservoir drill-in fluids
- Intervention fluids
- Breakers
- Spacers and Displacement Chemicals
- Specialized Tools
- Completion Fluids
- Filtration
- Fluid-loss control systems
- Packer fluids

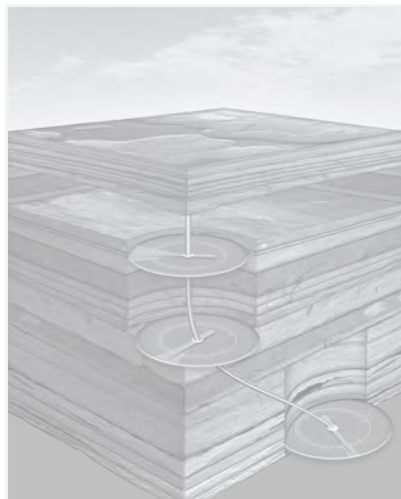

### Dynamic Pressure Management

- Rotating Control Devices
  - Low Pressure
  - High Pressure
- Fluid Separation Products
  - Mud Gas Separators
  - D-GASSERS
  - TOGA (TOTAL GAS CONTAINMENT)
- Flow Control Products
  - Drilling Chokes
  - Choke Manifolds
  - Choke Control Consoles
- Flow Measurements Products
  - CARBONTRACKER gas flow



## Performance Beyond Compliance

Dealing with the high volumes of solids and fluids produced while drilling is only part of today's Drilling Waste Management story. M-I SWACO offers a proactive approach that provides new opportunities to reduce the consumption of resources, and increase their reuse. Alongside compliance with environmental regulations, our solutions are also helping customers improve performance; both operationally and economically.

### Solids Control

M-I SWACO solids control packages comprise a complete line of cutting-edge technologies engineered to optimize drilling efficiencies by reducing fluid losses, HSE impact, and costs.

The all-inclusive solids control offering comprises advanced shale shakers and associated OEM composite screen, flow dividers and shake vacuum systems, new-generation centrifuges and pumps, D-SILTERs and D-SANDERS, cuttings dryers, gumbo chains and agitators. The solids control and separation suite also includes the pioneering RHE-USE system for the continual use of invert emulsion drilling fluids without high rates of dilution, state-of-the-art dewatering solutions and the revolutionary INTELLIGENT FLUID MONITORING service.

### Cuttings Management

M-I SWACO offers an industry-leading portfolio of cost-effective technologies designed to reduce the HSE footprint of offshore and onshore drilling operations. New generation drilling waste management technologies include vacuum collection systems and the fully automated CLEAN CUT and companion CLEAN BULK fully enclosed pneumatic technologies for the offshore containment, handling, temporary storage and transport of water, synthetic and oil-base drill cuttings. The cuttings management solutions also include advanced thermal desorption technologies, including the HAMMERMILL onshore desorption technology, the modular offshore HAMMERMILL design - both of which rely on direct mechanical heating - and the compact THERMAL PHASE SEPARATION technology. M-I SWACO also has been a pacesetter in the planning, execution and monitoring of in-situ injection of drilling waste with the industry's only comprehensive CUTTINGS RE-INJECTION (CRI) Assurance program.

### Fluids Processing

M-I SWACO has redefined fluids processing with an integrated and all-inclusive suite of cradle-to-grave technologies that optimize cost-effective performance, while reducing the fluid waste stream. The portfolio encompasses fully customized mud mixing technologies, including the advanced HI-RIDE high-speed eductor and the HI-SIDE Blender for in-line dilution. Setting the standard for safe and efficient drilling performance, we offer the closed-loop PRESSURE AND FLUID MANAGEMENT SYSTEM (PFMS) that automatically controls pressure and removes solids and gas from the drilling fluid; crossflow filtration units for optimum fluid purity and the industry's most advanced mud coolers. At the end of the process, our revolutionary AUTOMATIC TANK CLEANING technology and strategically located ENVIRONMENTAL RECOVERY UNITS have raised the bar on the safe and ultra-efficient recovering and recycling of liquid waste to reduce operators' environmental footprints.





### We work with operators to:

- Address specific waste management challenges while keeping pace with drilling
- Meet or exceed local regulations, as well as corporate responsibility and sustainability objectives
- Improve well site economics and the viability of operations
- Minimize produced waste volumes and treatment requirements
- Introduce onsite treatment capabilities that minimize or remove the need for costly waste transportation
- Increase the reuse of valuable drilling fluids and natural resources to minimize consumption and waste volumes
- Preserve fluid quality to protect downhole equipment, prevent NPT, improve drilling performance and protect the production potential of the reservoir

### Broad capabilities for diverse challenges

Wherever you operate, M-I SWACO provides access to global capabilities and leading technologies, supported by a network of unmatched resources and specialist expertise.

Through a longstanding program of research and development, M-I SWACO strives to constantly improve the performance of our technologies. This commitment also results in innovations designed to meet the changing requirements of a new generation of wells.

### Protecting people, safeguarding places

Wherever they are, M-I SWACO people are dedicated to operating safely; protecting their colleagues, customers and the communities in which they work. Whether operating at pristine frontiers or in established, mature fields, they respect these environments at all times. From the lab to the office to the wellsite, each member of the M-I SWACO team is dedicated to meeting client expectations.

### Supporting a full range of operations

M-I SWACO can help customers improve performance and protect valuable assets across the full E&P lifecycle. Drilling Waste Management is one of a wide range of technical disciplines that also include:

- Drilling Fluids and Systems
- Completion Fluids and Systems
- Production Technology and Chemicals
- Dynamic Pressure Management

# MONGOOSE PRO Shale Shaker



With the new generation MONGOOSE PRO dual-motion shale shaker, M-I SWACO has combined balanced and progressive elliptical motion technology for a shaker that adapts as drilling conditions change.

As drilling conditions change, the evolutionary MONGOOSE PRO dual-motion shaker can be adjusted while operating. Simply flipping a switch on the control box reconfigures the shaker from Capacity to Normal Mode.

## Features

- Dual motion: 7.5 G capacity/ 6.5 G normal
- Single switch controls motion changes during operation
- Utilizes pre-tension composite screens
- Patented ultra-tight seal between screen and screen bed
- Largest net (API) screen area among shakers of similar footprint
- Increased screen visibility
- Can be aligned with up to four shakers
- Comparatively small footprint
- Patented high-capacity distribution box
- Heavy duty, reliable, mechanical deck adjustment system
- Corrosion resistant deck jacks
- Low weir height

## Benefits

- Increases fluid capacity and solids conveyance rate when operating in capacity mode
- Maximizes fluid recovery and screen life when operating in normal mode
- Allows for continuous shaker operations when switching between motions
- Facilitates fast screen change out
- Eliminates costly solids bypass
- Promotes safer screen changes and inspections
- Minimizes maintenance costs
- Reduces dilution, chemical requirements
- Recovers valuable drilling fluid for reuse
- Reduces waste stream
- Lowers costs
- Improves environmental performance

# Key features of the MONGOOSE PRO shale shaker



Increased access for inspection, installation, and removal of screens



Two oilfield proven 2.5 HP motion generators



Deck angle can be adjusted while processing fluid. Adjustment Range is -3° to +3°



Largest non-blanked screen area among shakers of similar footprint: 21.2 ft<sup>2</sup> (1.97 m<sup>2</sup>)



Patented ultra-tight seal between screen and screen bed



# Motion comparisons for the MONGOOSE PRO shale shaker

## Comparison of motion

### Capacity Mode

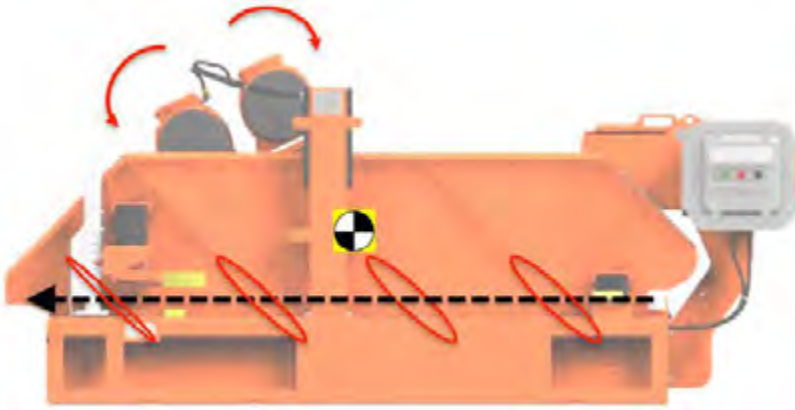

- Increases G-forces 7.5 Gs
- Speeds conveyance
- Increases shaker-fluid capacity
- Enables shaker to process heavier solids loads
- Enhances cuttings-processing volume

### Normal Mode

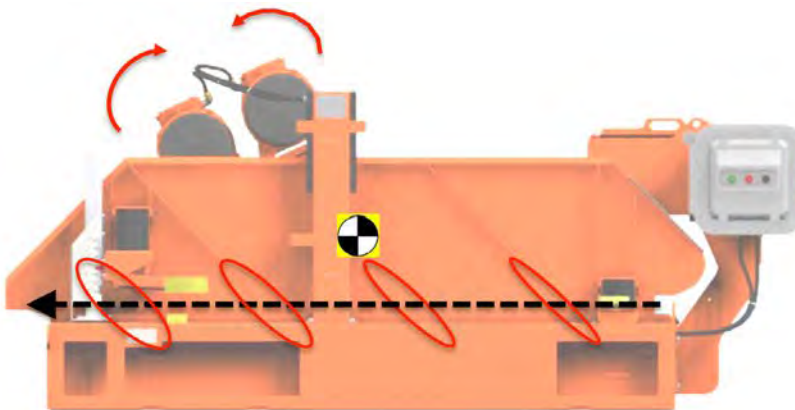

- Reduces G-forces (6.5 Gs)
- Optimizes solids removal
- Maximizes drilling-fluid recovery
- Drier cuttings
- Extends screen life

### Linear Motion (Configuration available on special request)

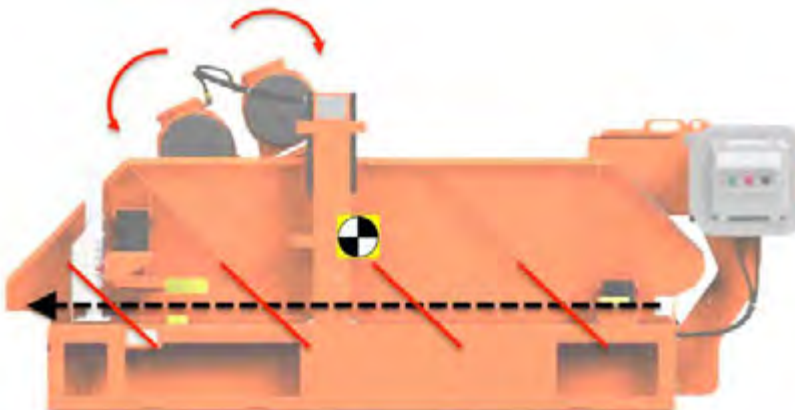

- Linear motion only (8 Gs)
- Applications where a linear single motion high G shaker is required



# Technical specifications for the MONGOOSE PRO shale shaker

## Basic MONGOOSE PRO shaker with header box specifications

### Dimensions

- Length: 119.8 in. (3,044 mm)
- Width: 68.9 in. (1,749 mm)
- Height at 0°: 52.4 in. (1,330 mm)
- Weir height: 29 in. (737 mm)
- Weight: 3,300 lb (1,500 kg)

### Screen Deck and Screens

- Screen area:
  - Gross: 29.4 ft<sup>2</sup> (2.73 m<sup>2</sup>)
  - Net (API): 21.2 ft<sup>2</sup> (2.0 m<sup>2</sup>)
- Deck-angle adjustment: +2° to +8°

### Vibratory Motion Type

- Normal mode: 6.5G
- Capacity mode: 7.5G

### Motor Specifications

- Voltage: 220-690 VAC
- Speed: 1800RPM/60Hz; 1500RPM/50Hz
- Certifications: UL/cUL, CE, ATEX rated

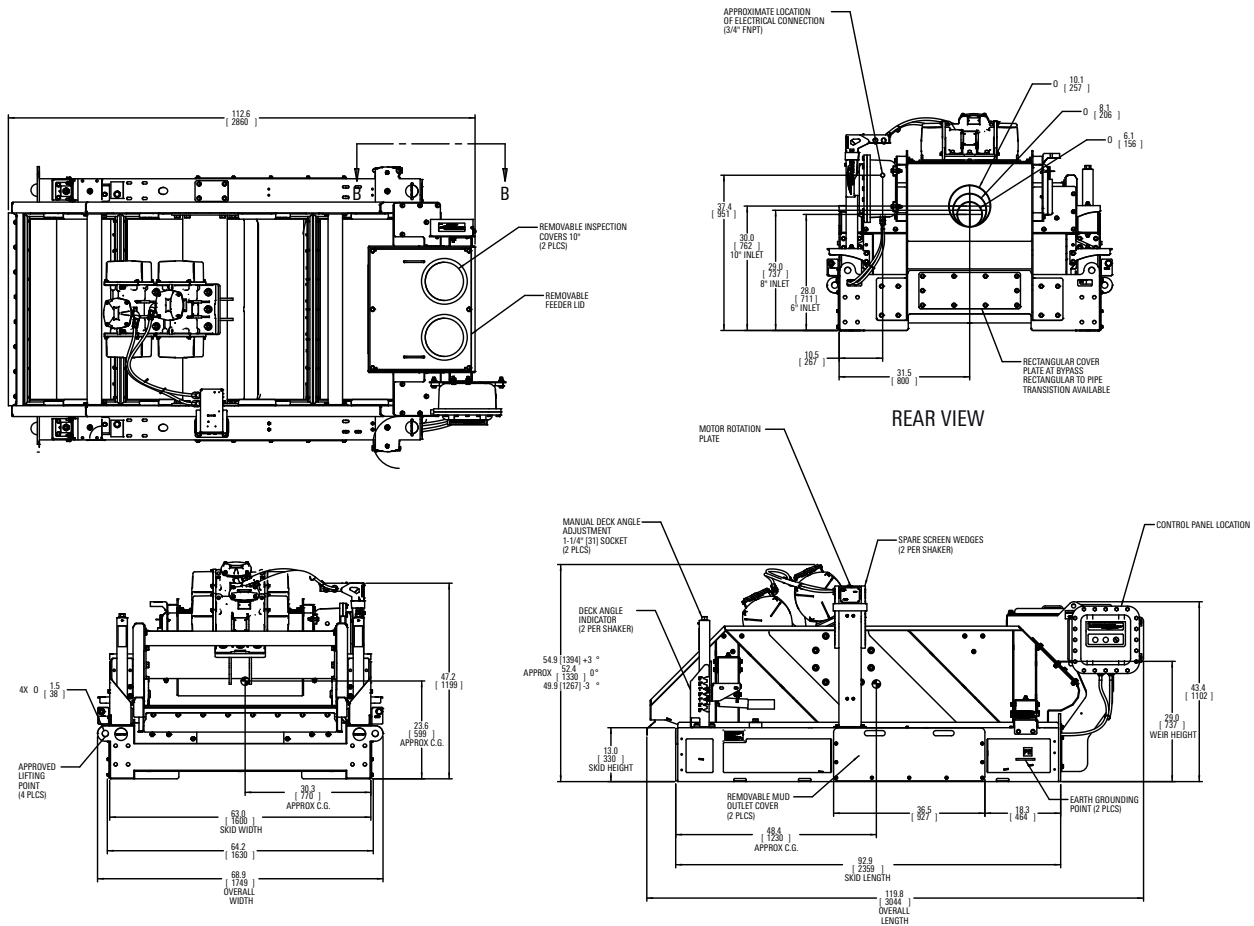

## The MONGOOSE PRO is available in the following configurations.

- Low Profile skid for decreased weir height
- Compact
- Dual, Triple, or Quad shakers mounted on a single skid with a common feed and single lift point
- Mud cleaner using two or three 12" D-SANDER<sup>†</sup> cones and six, eight, or ten 4" D-SILTER<sup>†</sup> twin cones

# MEERKAT PT Shale Shaker



M-I SWACO has combined linear and balanced elliptical motion technology to create the revolutionary MEERKAT PT<sup>+</sup> dual-motion shaker. The design incorporates a 0.6 hp vibrator motor that allows it to perform on an unparalleled level.

But as drilling conditions change, the MEERKAT PT dual-motion shaker can be adjusted by simply flipping a switch on the control box to reconfigure the shaker from linear to balanced elliptical motion. There is no need to suspend or shut down operations. With the MEERKAT PT shaker operating in the gentler balanced elliptical mode, solids encounter reduced G-forces and longer screen residence time. This results in drier solids, improved drilling-fluid recovery, longer screen life and reduced operating costs.

## Features and Benefits

- Units can be customized to meet both tight-space requirements and high-performance criteria
- All configurations are compact and modular
- Linear motion for fast conveyance and heavy loading; balanced elliptical motion for maximum retention time and drier cuttings
- Elliptical motion at the flip of a switch without stopping the shaker
- Balanced basket functions flawlessly in either linear or balanced elliptical mode, with dry, light loads or wet, heavy loads
- Most reliable mechanical jacking system in the industry — simple and easy to use; requires no pinning
- Unique distribution box option can replace flowline possum belly, providing increased handling capacity and dampening the velocity of fluid from the flowline
- Pre-tensioned composite screens for fast screen changes and overall ease of use
- Ultra-tight seal between screen and screen bed eliminates solids buildup and costly bypass of solids
- Largest net-usable screen area among shakers of similar footprint: 15.9 ft<sup>2</sup> (1.5 m<sup>2</sup>)

# Key features of the MEERKAT PT shale shaker



Utilizes 3 MONGOOSE Composite screens



Patented high capacity distribution box with low weir height



Dual motion: Balanced Elliptical/Linear change at the "flip of a switch"

Two 2.5 hp motion generators



Largest non-blanked screen area among shakers of similar footprint: 21.2 ft<sup>2</sup> (1.97 m<sup>2</sup>)



Patented ultra-tight seal between screen and screen bed



Heavy duty, reliable, mechanical deck adjustment system. Jacks with corrosion resistant coating.

# Motion comparisons for the MEERKAT PT shale shaker

## Comparison of balanced elliptical motion to linear motion

### Balanced Elliptical Motion

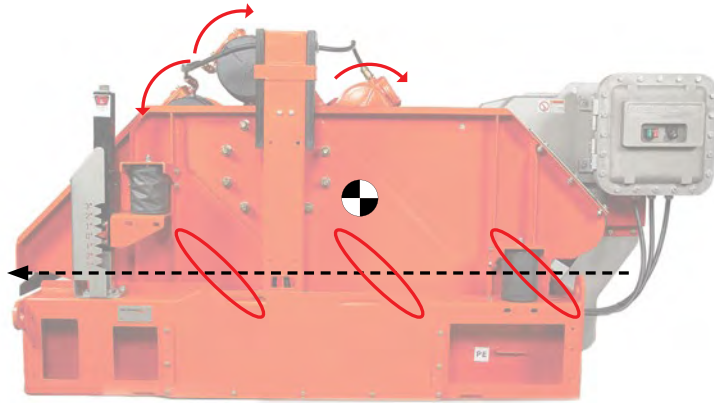

- Uniform elliptical motion at all points on basket
- Reduces G-forces (5.7 G's maximum)
- Optimizes solids removal
- Maximizes drilling-fluid recovery
- Drier cuttings
- Extends screen life

### Linear Motion

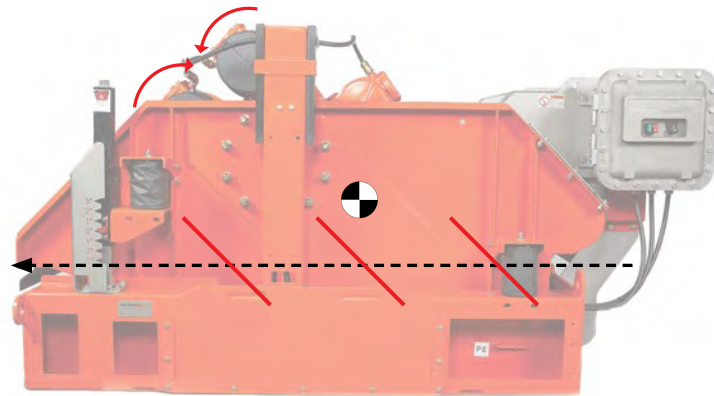

- G-force linear motion up to 6.9 G's
- Speeds conveyance
- Increases shaker-fluid capacity
- Enables shaker to process heavier solids loads
- Enhances cuttings-processing volume



# Technical specifications for the MEERKAT PT shale shaker

## Basic MEERKAT PT shaker with header box specifications

### Specifications

- Length: 94 in. (2,388 mm)
- Width: 74.8 in. (1,900 mm)
- Weir height: 22.3 in. (565 mm)
- Height: 44 in. (1,118 mm)
- Weight: 2,885 lb (1,311 kg)

### Mounting Footprint

- Length: 75.2 in. (1,911 mm)
- Width: 59 in. (1,499 mm)

### Screen Deck and Screens

- Screen area:
  - Gross: 22 ft<sup>2</sup> (2 m<sup>2</sup>)
  - Net (API): 15.9 ft<sup>2</sup> (1.5 m<sup>2</sup>)
- Deck-angle adjustment:
  - 3° to +3°
- Screen type: Pre-tensioned
  - 4 x 2 ft (1.2 x 0.61 m)

### Basket Isolation

- Powder-coated steel springs

### Motor Specifications

- Two (2) primary vibrator motors
- One (1) secondary vibrator motor on dual-motion model
- 440-480V/60 Hz/1,800 rpm or 380-415V/50 HZ/1,500 rpm
- Explosion proof
- Class I, Groups C and D UL/cUL, CE, ATEX, NORSOK

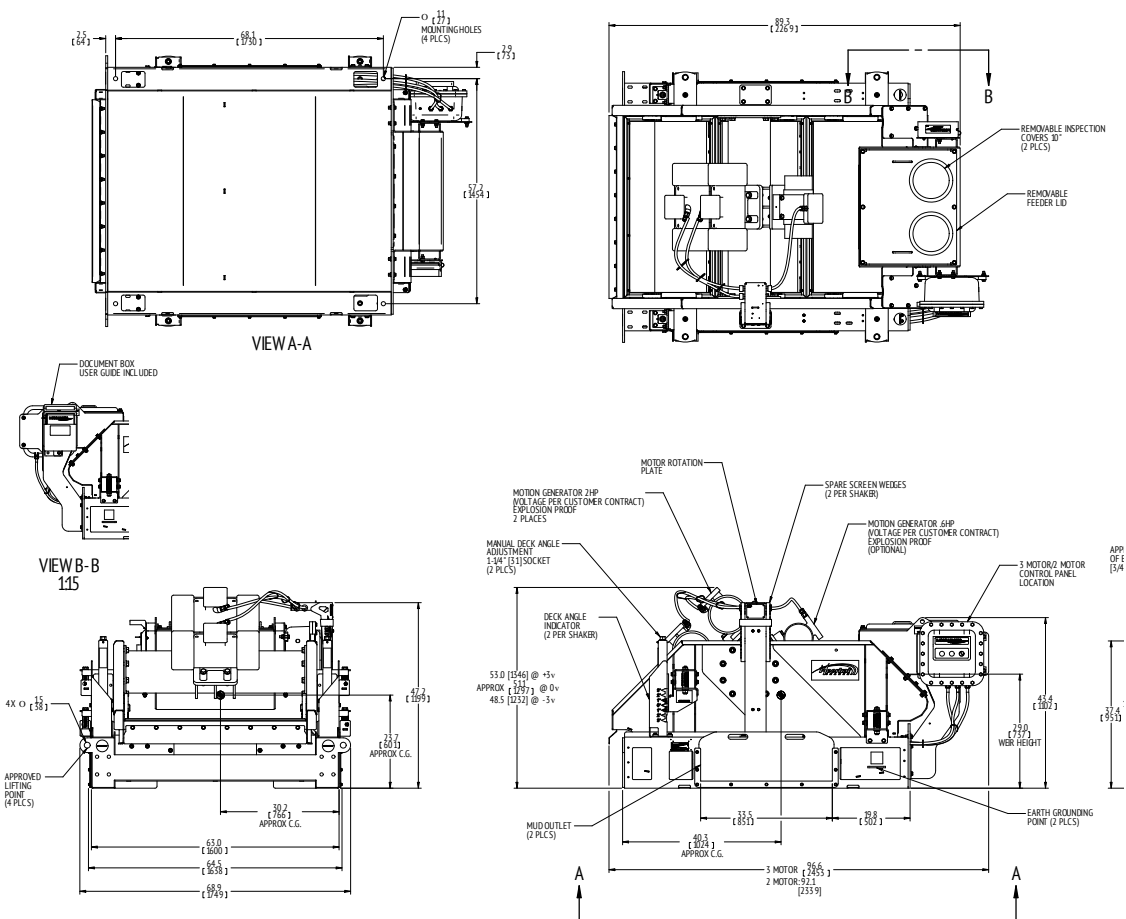

## The MEERKAT PT is available in the following configurations.

- Low Profile skid for decreased weir height
- Dual or Triple, shakers mounted on a single skid with a common feed and single lift point
- Mud cleaner using two or three 12" D-SANDER<sup>†</sup> cones and six, eight, or ten 4" D-SILTER<sup>†</sup> twin cones

# MD-2 Dual-Deck Shale Shaker



The uniquely engineered MD-2 dual flat-deck shaker with DURAFLO<sup>+</sup> composite screen technology has taken the solids control process to an entirely new level of efficiency.

In providing primary solids removal from both oil and water-base drilling fluids, the MD-2 dual-deck shaker delivers high-capacity separation efficiency and operational flexibility in a value-added footprint. Capable of easily switching between balanced elliptical and progressive elliptical motions, the MD-2 shaker adapts instantly to the continual changes in drilling conditions.

To further enhance its performance the dual-deck MD-2 shale shaker is engineered to unlock the full solids control potential of the strong and efficient M-I SWACO DURAFLO family of composite-frame screens. Compared to conventional shaker screens, the productive life of our DURAFLO pre-tensioned composite screens is considerably longer and the overall screening area appreciably larger.

The extended useful life of composite screens in tandem with the higher capacity of a single dual-bed, flat-deck shaker assures a cost-effective and high-performing solids control package.

## Features

- Dual-deck design with full primary and half-width scalping decks
- Progressive and balanced modes of elliptical motion
- Durable pretension composite screens
- Small footprint design
- Flexible fluid distribution
- Modular platform
- Select components are fabricated with durable stainless steel materials
- Adjustable deck angles
- +7 G's operating mode
- Can accommodate most gas detection devices
- Two screen vibratory motors
- Pneumatic screen clamping/sealing system
- Vapor recovery hoods
- CE compliant

## Benefits

- Delivers high processing capacities
- Adjusts instantly to changing drilling conditions
- Provides longer screen life
- Generates drier cuttings
- Enhances overall solids control efficiencies
- Conveys solids quickly out of fluid pool
- Decreases NPT
- Fits restricted space requirements
- Promotes easy deck adjustments
- Requires only marginally more power than single-deck unit
- Removes harmful vapors
- Reduces maintenance
- Lowers solid waste volumes
- Reduces drilling, waste disposal costs
- Helps ensure environmental compliance
- Raises HSE profile

## Key features of the MD-2 dual deck shale shaker



Open access to easily inspect scalping and primary deck screens



Two oilfield proven 3.7 HP motion generators



Deck angle can be adjusted while processing fluid.  
Adjustment Range:  
- Scalping deck: -1° to +3°  
- Primary deck: +3° to +7°



Composite lightweight MD series screens with self latching mechanism and integrated seal with the following gross screen area:  
- Scalping deck: 16.9 ft squared (1.6 m<sup>2</sup>)  
- Primary deck: 33.9 ft squared (3.1 m<sup>2</sup>)



U-shape screen clamping actuators designed with continuous toggle to allow installation from discharge end of shaker

# Motion comparisons for the MD-2 dual deck shale shaker

## Comparison of balanced and progressive elliptical motion

### Balanced Elliptical Motion

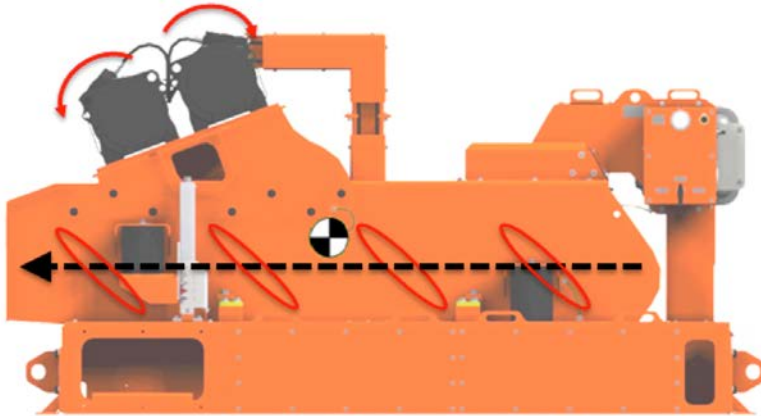

- Balanced elliptical motion 7.0 Gs
- Speeds conveyance
- Increases shaker-fluid capacity
- Enables shaker to process heavier solids loads
- Enhances cuttings-processing volume

### Progressive Elliptical Motion

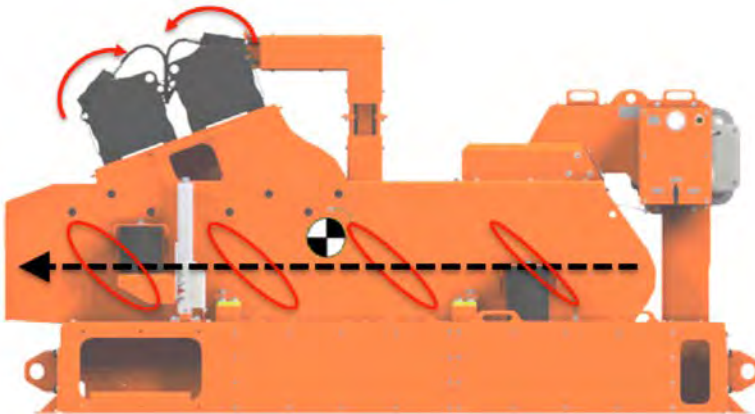

- Progressive elliptical motion 6.5 Gs
- Speeds conveyance
- Increases shaker-fluid capacity
- Enables shaker to process heavier solids loads
- Enhances cuttings-processing volume



# Technical specifications for the MD-2 dual deck shale shaker

## Basic MD-2 dual deck shale shaker specifications

### Dimensions

- Length: 125.0 in. (3,175 mm)
- Width: 74.7 in. (1,898 mm)
- Height at 0°: 63.5 in. (1,613 mm)
- Weir height: 39.8 inch (1011 mm)
- Weight: 6,200 lbs (2,812 kg)

### Screen Deck and Screens

- Gross screen area:
  - Scalping deck: 16.9 ft<sup>2</sup> (1.6 m<sup>2</sup>)
  - Primary decks: 33.9 ft<sup>2</sup> (3.1 m<sup>2</sup>)
- Net (API) surface area:
  - Scalping deck: 10.6 ft<sup>2</sup> (1.0 m<sup>2</sup>)
  - Primary decks: 21.1 ft<sup>2</sup> (2.0 m<sup>2</sup>)
- Deck-adjustment system:
  - Scalping deck: +3° to -1°
  - Primary decks: +3° to +7°

### Vibratory Motion Type

- Normal mode: 6.5 G
- Capacity mode: 7.0G

### Motor Specifications

- Voltage: 220-690 VAC
- Speed: 1800RPM/60Hz; 1500RPM/50Hz
- Certifications: UL/cUL, CE, ATEX rated

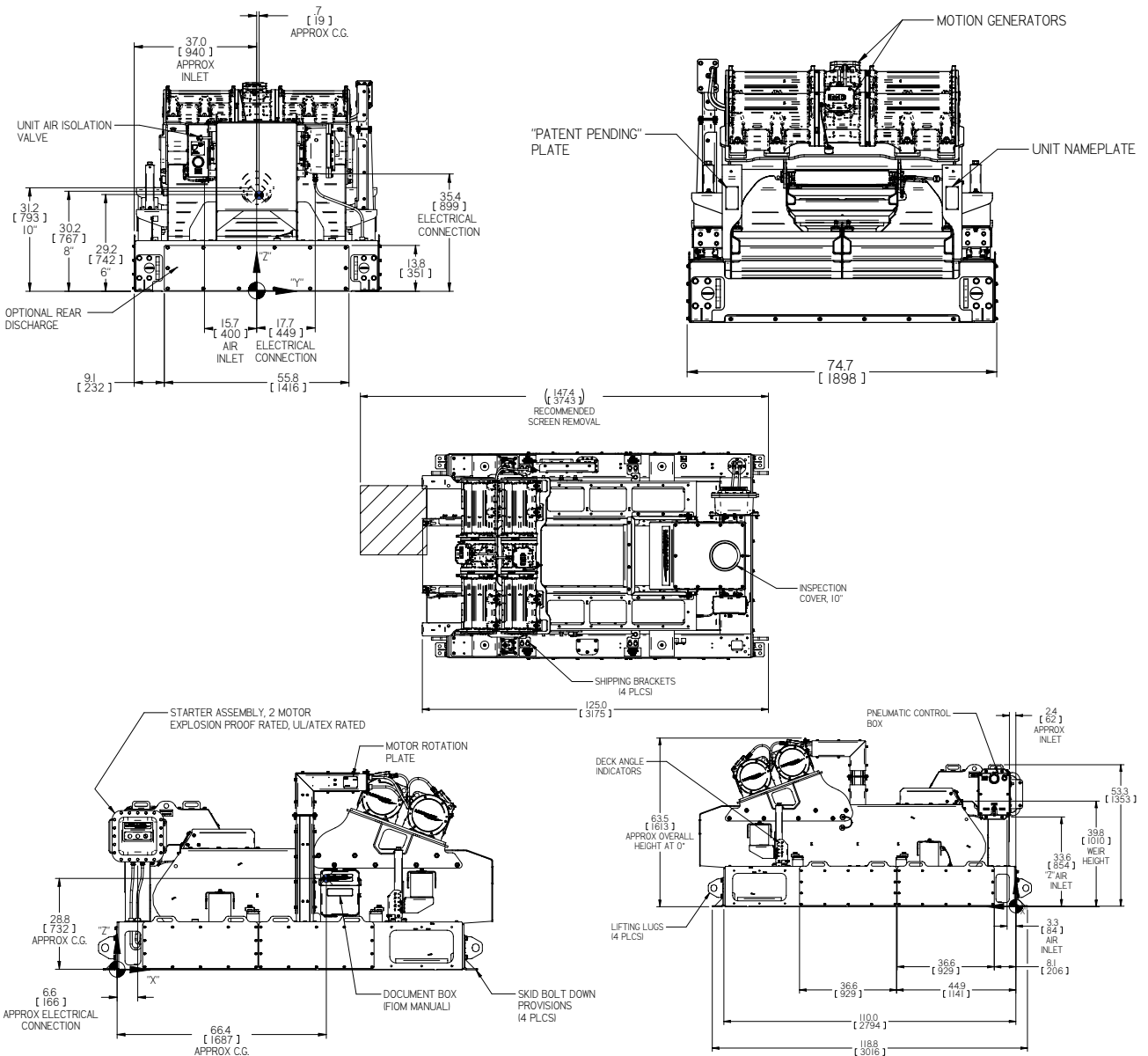

# MD-3 Triple-Deck Shale Shaker



Changing drilling conditions require immediate, flexible solids-control solutions. Environmental requirements demand up-to-the-minute conformance with ever stricter criteria. Rig space, especially offshore but also onshore, is at an all-time premium as more and more technology crowds the working environment.

The MD-3 shale shaker lets you meet all of these challenges — small footprint, the most effective solids-control options and the ability to adapt quickly to changing drilling conditions — with a compact, high-performance solution.

## Features

- Dual motion: 7.2 G capacity mode or 6.3 G normal mode
- Three-deck configuration
- Pneumo-hydraulic controls on front of shaker provide deck adjustment
- Configured to all common power supply requirements
- Standard integral fume extraction hood
- Standard spray bar for scalping deck
- Pre-tension, lightweight composite screens (<15 lbs [6.8 kg])
- Modular bolting provisions
- Front-loaded screens
- Pneumatic screen clamping system with controls mounted on front of shaker
- Screen bed with sloped bottom
- Designed to HSE-driven standards

## Benefits

- Increases fluid capacity and solids control
- Maximizes fluid recovery
- Maximizes screen life
- Decreases space requirements
- Reduces mud losses from screens
- Promotes flexible shaker configurations
- Recovers loss circulation, wellbore strengthening materials
- Replaces multiple shakers
- Allows for easy screen changes
- Provides safer, faster screen changes
- Decreases maintenance requirements
- Increases process capacity
- Delivers drier cuttings
- Reduces costs

# Key features of the MD-3 triple deck shale shaker

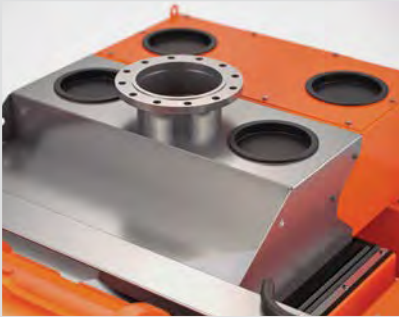

Fluid is split into four streams on top flowback pan and is directed to primary decks through four rear ducts



Two state-of-the-art, oilfield proven 3.7-HP motion generators with 1,800 rpm maximum speed

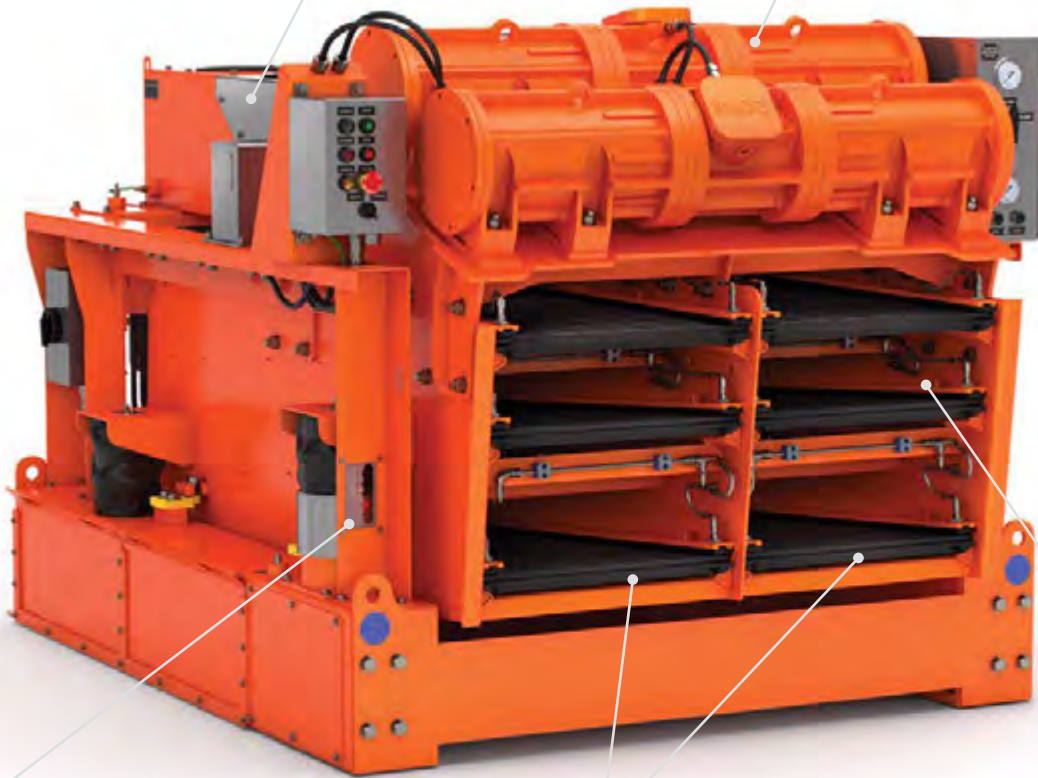

Deck angle can be adjusted while processing fluid.  
Adjustment range:  
- Scalping deck: +3° to -1°  
- Primary decks: +8° to +4°



Standard configuration has one scalping deck and two primary decks. Pre-tensioned, composite scalping screens have the following gross screen areas:  
- Scalping deck: 25.4 ft<sup>2</sup> (2.4 m<sup>2</sup>)  
- Primary decks: 50.8 ft<sup>2</sup> (4.7 m<sup>2</sup>)



Screen-clamping actuators designed with continuous toggle to allow installation from discharge end of shaker

# Motion comparisons for the MD-3 triple deck shale shaker

## Comparison of balanced and progressive elliptical motion

### Balanced Elliptical Motion

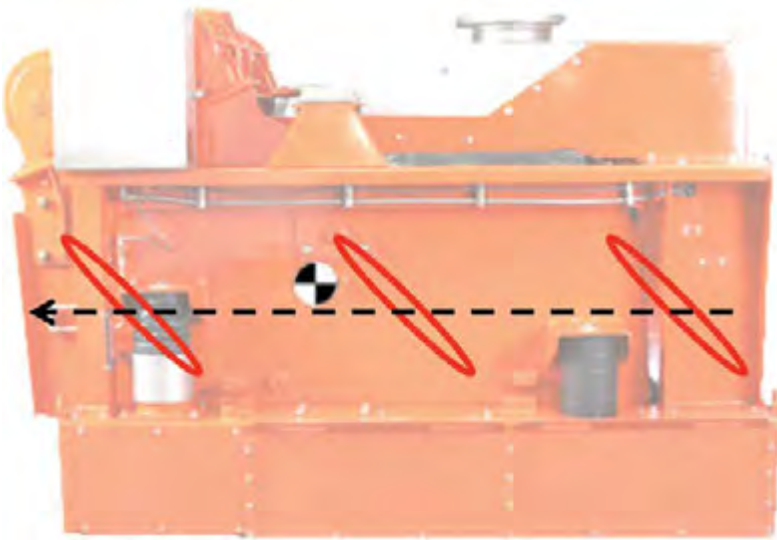

- Balanced elliptical motion 7.2 Gs
- Speeds conveyance
- Increases shaker-fluid capacity
- Enables shaker to process heavier solids loads
- Enhances cuttings-processing volume

### Progressive Elliptical Motion

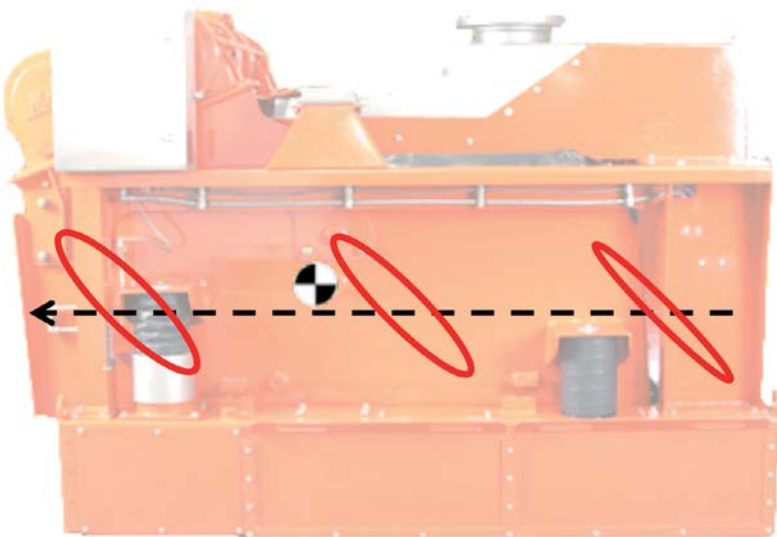

- Reduces G-forces (6.3 Gs maximum)
- Optimizes solids removal
- Maximizes drilling-fluid recovery
- Drier cuttings
- Extends screen life

### The MD-3 is available in the following configurations.

- Series mode for applications where Wellbore Strengthening Materials are used
- Parallel mode for increased fluid capacity
- Mud cleaner using two or three 12" D-SANDER<sup>+</sup> cones and six, eight, or ten 4" D-Silter twin cones



# Technical specifications for the MD-3 triple deck shale shaker

## Basic MD-3 triple deck shale shaker specifications

### Dimensions (Parallel Mode)

- Length: 103.2 in. (2,621 mm)
- Width: 77.4 in. (1,967 mm)
- Height at 0°: 67.7 in. (1,720 mm)
- Weir height: 45.5 in (1,156 mm)
- Weight: 6,450 lb (2,926 kg)

### Dimensions (Series Mode with Recovery Trough)

- Length: 113.5 in. (2,882 mm)
- Width: 77.4 in. (1,967 mm)
- Height at 0°: 67.7 in. (1,720 mm)

- Weir height: 45.5 in (1,156 mm)
- Weight: 6,780 lb (3,075 kg)

### Screen Deck and Screens

- Gross screen area:
  - Scalping deck: 25.4 ft<sup>2</sup> (2.4 m<sup>2</sup>)
  - Primary decks: 50.8 ft<sup>2</sup> (4.7 m<sup>2</sup>)
- Net (API) surface area:
  - Scalping deck: 15.8 ft<sup>2</sup> (1.5 m<sup>2</sup>)
  - Primary decks: 31.7 ft<sup>2</sup> (2.9 m<sup>2</sup>)
- Deck-adjustment system:
  - Scalping deck: +3° to -1°
  - Primary decks: +4° to +8°

### Vibratory Motion Type

- Normal mode: 6.3G
- Capacity mode: 7.2G

### Motor Specifications

- Voltage: 220-690 VAC
- Speed: 1800RPM/60Hz; 1500RPM/50Hz
- Certifications: UL/cUL, CE, ATEX rated

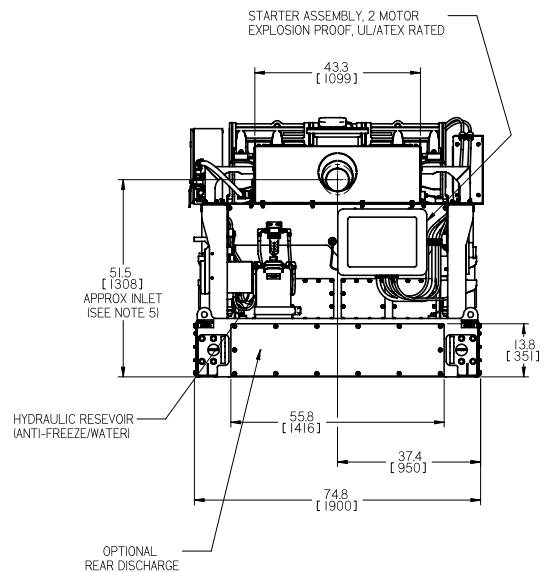
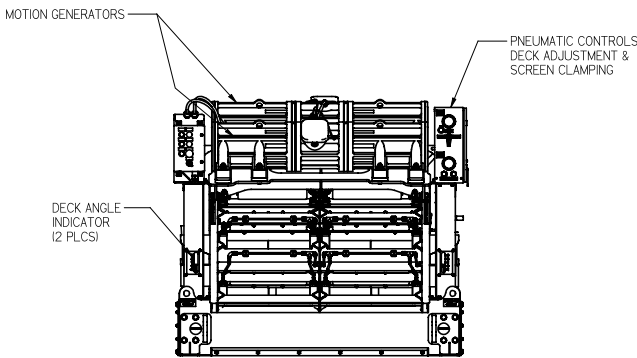
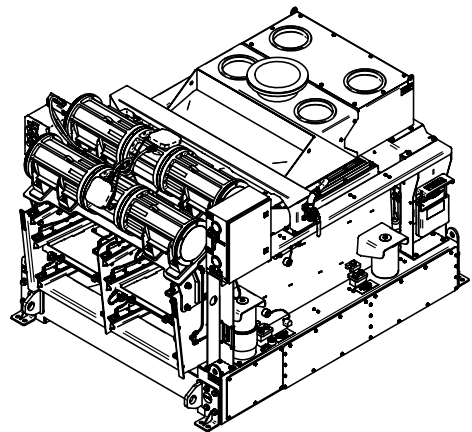
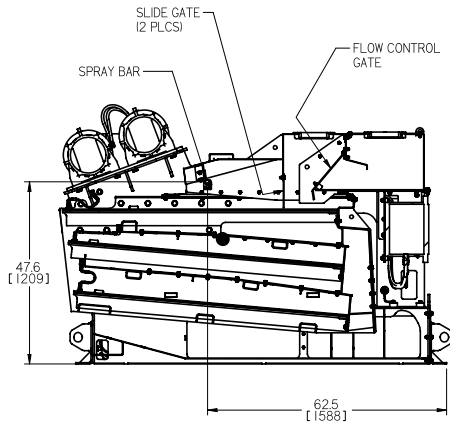

# Vibratory Systems Analysis Testing (VSAT) Program



The M-I SWACO VSAT program is a proven solution for operators who are experiencing sub-par shale-shaker performance. The VSAT service, provided as part of the VSAT program, includes an inspection of the problem shakers, a review of rig practices, a vibratory-motion analysis of the shakers, a written evaluation of the findings and recommendations for improving performance. More than 30 major operators have used the VSAT service with positive results.

As an option, the M-I SWACO VSAT specialist can conduct a training session for the rig's shaker hands. Subjects covered include screen selection, rig-specific operating and maintenance procedures, and best practices compiled from worldwide operating experience.

## How to tell when you need the VSAT program and service

**If you are experiencing one or more of these critical problems, your rig will benefit from the VSAT program:**

- Screen failures
- Fluid-capacity problems: drilling fluid flowing off the end of the shaker screens
- Poor solids conveyance
- Energy (G-force) output is less than expected

## Features

- Applicable to all common brands of shakers and screens
- Precise determination of all shaker-related problems
- Detailed equipment database of shakers and screens
- Clear, detailed written reports
- Training available for rig crews

## Benefits

- Improved shaker performance, immediately and long-term
- Drier cuttings and lower disposal volumes
- Improved ROP and drilling fluid recovery
- Better drilling-fluid performance and longer life
- Better solids handling
- Cuts costs
- Reduced drilling waste volumes
- Longer screen life, better screen performance

### Phase 1.

The VSAT specialist first performs a thorough inspection of the shakers, removing all screens, checking the temperature of the motor bearings, removing the counterweight covers and inspecting the weights, and inspecting the seals, tensioning devices and support devices. The complete inspection process includes:

- Installation – mud flow, shaker levels, weir heights, discharges
- Frame and iron – tilt system, cracking, support blocks
- Mechanics – counterweights, motors, and conveyance
- Hardware – springs, bed rail, ball valves
- Electronics – power cables, grounding, controls
- Consumables – tension devices, deck rubber, bed seals

### Phase 2.

In the next phase, the specialist inspects each shaker to see if the equipment is operating within factory specifications by connecting a dual-axis accelerometer to key test points on each shaker; rare-earth magnets ensure a solid contact. Data from the accelerometer is evaluated via proprietary vibration-analysis software and is output in an easy-to-read format. M-I SWACO maintains an up-to-date database of detailed information for all 30 of the common shale shaker makes and models in the oilfield.

### Phase 3.

Finally, the specialist compiles all of the motion-analysis data, verbal communications and inspection information into a clearly written report that contains recommendations for restoring shaker efficiency, graphic output from the analysis software and a multipage section of best practices.

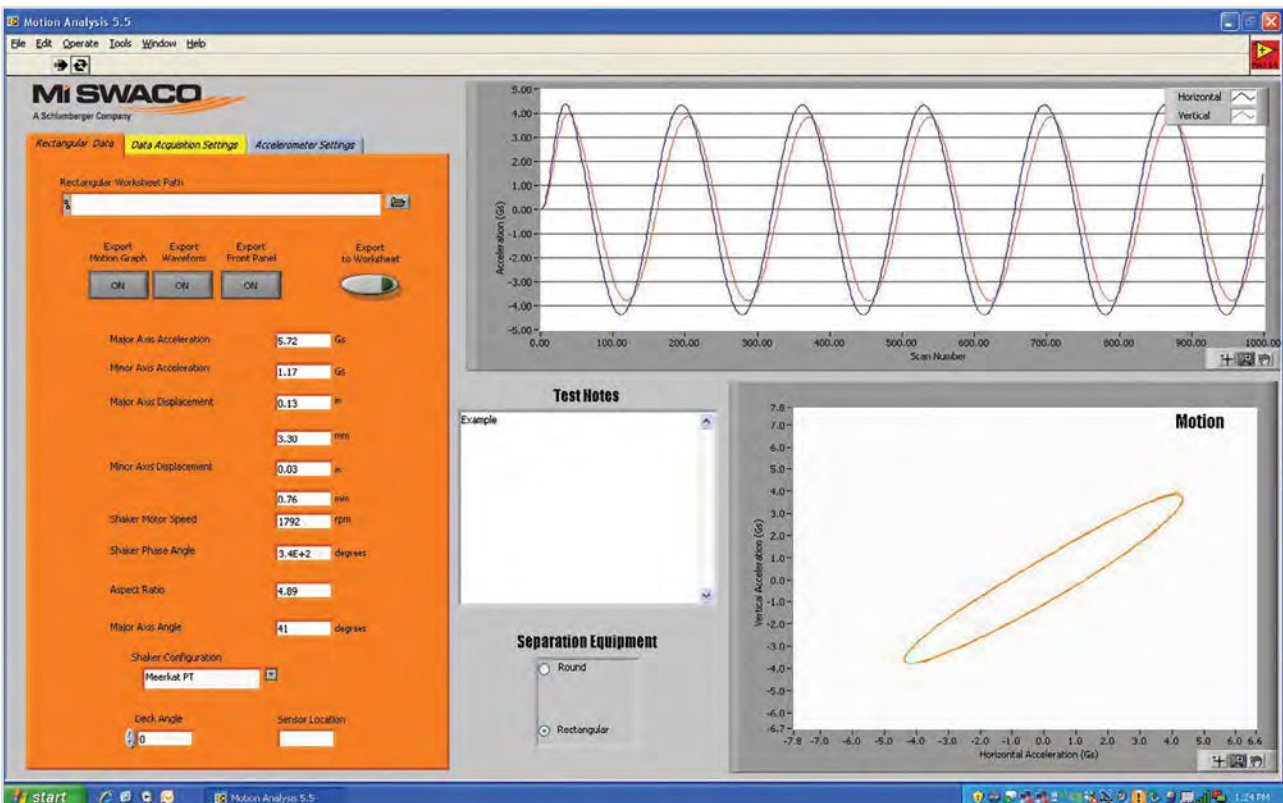



# High-Volume Mud Cleaners



The M-I SWACO line of mud cleaners consists of a two-stage separation process using a combination of hydrocyclones mounted over a shale shaker to operate as a single unit. Designed to handle the entire circulating volume, mud cleaners are effective on both weighted and unweighted drilling-fluid systems in removing and drying solids while retaining the expensive liquid.

The hydrocyclones make the primary separation with underflow directed onto the shaker's vibrating screen. Used correctly, the M-I SWACO mud cleaners lower both drilling-fluid and disposal costs.

## Features and Benefits

### Versatile

- M-I SWACO mud cleaners can be configured with an M-I SWACO D-SILTER<sup>†</sup>, a D-SANDER<sup>†</sup> or both over a high-performance shaker to process weighted or unweighted drilling-fluid systems

### Environmentally efficient

- Removing and drying drilled solids helps meet environmental regulations by minimizing waste generated and reducing disposal costs

### Minimizes maintenance

- Continuous removal of sand and abrasive cuttings from drilling fluids cuts downtime and reduces repair and replacement of worn parts on downstream equipment

### Wide range of mud cleaners for your drilling-fluid system

- M-I SWACO mud cleaners are available in a variety of configurations
- The Model 6T4 (12 clone), Model 8T4 (16 clone) and Model 10T4 (20 clone) D-SILTERs, when matched with an M-I SWACO shale shaker, provide processing rates from 900 to 1,500 GPM (3,406.9 to 5,678.1 L/min). The Model 2-12 D-SANDER, when matched with an M-I SWACO shaker, provides processing capabilities to 1,000 GPM (3,785.4 L/min)
- The three-in-one Model 2-12 D-SANDER and Model 6T4 (12 clone) D-SILTER mounted over an M-I SWACO high-performance shaker provides the most versatile separation combination package with rates of 1,000 and 900 GPM (3,785.4 and 3,406.9 L/min) respectively

### Works with oil- or water-base muds

- M-I SWACO mud cleaners are designed to work with either oil- or water-base weighted muds, as well as with either dispersed or non-dispersed muds



## How it works

Mud cleaners combine a hydrocyclone system with a shale shaker to help remove the fine drilled solids from the drilling fluid.

Together, they have the capability to process the entire drilling-fluid circulation volume, and remove drilled solids from weighted mud systems; retaining expensive barite and liquids, and economically reducing hole problems associated with excessive drilled solids. Drilling fluid passes through a series of hydrocyclones - either D-SILTER or D-SANDER units -

that separate the fine, light particles from the heavy, coarse particles. Barite and other heavy drilled solids are then carried in the underflow to a 100- to 200-mesh vibrating screen. There, they are separated, with the barite passing through the screen and returning to the active system.

The M-I SWACO D-SILTER unit features the exclusive polyurethane TWIN SWACONE<sup>†</sup> D-SILTER cones with a unique 20° taper angle (compared to the 15° taper angle on most other units). The twin-cone design provides a 50% greater capacity than other 4 in. (102 mm) cones.

The M-I SWACO D-SANDER Models 2-12 and 3-12 are designed to remove sands and abrasive cuttings - 95% of all particles to 74 microns and more than 50% of particles to 40 microns.

The D-SANDER features your choice of two or three 12 in.- (304.8 mm) diameter replaceable, wear-resistant, polyurethane hydrocyclones and quick-release stainless-steel clamps for simplified changeout.

These high-volume mud-cleaner product combinations provide drillers a wide range of efficient, space-saving processing options including connection to centrifuges for barite recovery.

Mud cleaners can be installed on the single, dual and triple configurations:

- The D-SANDER unit is available in two- or three-cone
- The D-SILTER unit is available in six, eight or ten twin-cone
- Low profile (approx. 64 in. [1,626 mm] to top of trough)
- Integral bypass between shaker and D-SILTER/D-SANDER units
- Compact footprint
- Allows inspection/maintenance without ladders or scaffolds
- Operates as D-SILTER and D-SANDER units and flowline shaker independently

## These hydrocyclone options are available for all M-I SWACO shakers

D-SANDER Mud Cleaners						
Model	Number of Clones	Length in. (mm)	Width in. (mm)	Height in. (mm)	Weight lb (kg)	Capacity gpm (L/min)
1-12 D-SANDER (vertical)	1	33 (838.2)	19.5 (495.3)	74.4 (1,889.8)	401 (181.9)	500 (1,892.7)
2-12 D-SANDER (vertical)	2	36 (914.4)	51.5 (1,308.1)	71.2 (1,808.5)	1,125 (510.3)	1,000 (3,785.4)
2-12 D-SANDER (slant)	2	78 (1,981.2)	47.5 (1,206.5)	35.2 (894)	1,030 (467.2)	1,000 (3,785.4)
3-12 D-SANDER (vertical)	3	40.7 (1,033.8)	75.5 (1,917.7)	78.3 (1,988.8)	1,878 (851.9)	1,500 (5,678.1)
3-12 D-SANDER (slant)	3	83 (2,108.2)	71 (1,803.4)	41.5 (1,054.1)	2,450 (1,111.3)	1,500 (5,678.1)

D-SILTER Mud Cleaners						
Model	Number of Clones	Length in. (mm)	Width in. (mm)	Height in. (mm)	Weight lb (kg)	Capacity gpm (L/min)
4T4	8	52 (1,320.8)	30 (762)	56.1 (1,424.9)	680 (308.4)	600 (2,271.2)
6T4	12	66 (1,676.4)	30 (762)	56.1 (1,424.9)	800 (362.9)	900 (3,406.9)
8T4	16	80.3 (2,039.6)	30 (762)	56.1 (1,424.9)	925 (419.6)	1,200 (4,542.5)
10T4	20	94.5 (2,400.3)	32 (812.8)	60.3 (1,531.6)	1,150 (521.6)	1,500 (5,678.1)

Combo D-SANDER/D-SILTER Mud Cleaners							
Model of D-SANDER	Model of D-SILTER	Number of Clones	Length in. (mm)	Width in. (mm)	Height in. (mm)	Weight lb (kg)	Capacity gpm (L/min)
2-12 D-SANDER	4T4	12	129.5 (3,289.3)	72.8 (1,849.1)	97 (2,463.8)	7,072 (3,207.8)	1,000/900 (3,785.4/3,406.9)
2-12 D-SANDER	6T4	16	129.8 (3,296.9)	80.5 (2,044.7)	97 (2,463.8)	7,162 (3,248.6)	1,000/1,200 (3,785.4/4,542.5)

# DURAFLO Oilfield Screens

## The anatomy of the three-layer DURAFLO screen

DURAFLO screen frames consist of a high strength plastic and glass composite material that is reinforced with high-tensile strength steel rods.

- Exclusively patented by M-I SWACO (U.S. Patent # 6,675,975)
- First major platform advancement in oilfield screens industry
- Polypropylene frame molded around an internal steel cage
- Each layer of mesh is tensioned individually and precisely
- Co-molded Gasket Design

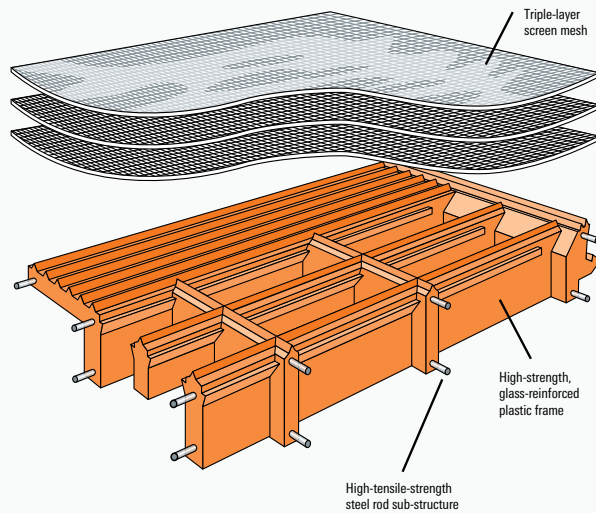

With more than 30 years experience in solids control and drilling waste management, it is only natural that M-I SWACO would introduce our patented composite frame technology to the industry. DURAFLO composite screens were developed by United Wire/M-I SWACO as an alternative to metal framed shale shaker screens being offered as an industry standard.

## Raising the bar with Composite OEM and Replacement Screen Technology.

Composite screens consist generally of a glass fiber filled, polypropylene frame in addition to a high strength steel internal reinforcing structure. Using a patented process, one to three layers of stainless steel wire cloth are bonded to the composite frame directly by melting the cloth directly to the top surface of the polymer frame. Both the composite design and production process are M-I SWACO patented. This exclusive technology has been used successfully in the industry for both OEM and replacement screens and has established proven and respected prominence.

Our technology advancement provides screens with:

- Higher throughput capacity
- Significantly longer operational life
- Increased open area via precision molding
- Higher conductance
- Efficient transport mechanisms
- Lighter weight = increased shaker G's

In the world of oil field drilling, various formation types are present. As a result, shaker screens are available with a variety of options. These options however, are usually presented with a trade-off in regard to production platform and available mesh grade. M-I SWACO's Composite Screen Technology along with its patented XR mesh offers the best of both worlds. Instead of settling, we give operators the power to choose among the best options available while maintaining cost effectiveness.

# Screen Performance: API Compliance

Leading the industry in quality and value, M-I SWACO is committed to the new international standard, API RP 13C. We are committed to demonstrating our superior and diverse offerings without bias.

Our complete offerings are:

- API compliant.
- API RP 13C test results via an independent lab
- Continuously confirmed and verified by our own Engineering Department.
- Made using the best raw materials available as to not compromise quality

## What is API RP 13C?

API RP 13C is an internationally standardized testing and labeling procedure via the American Petroleum Institute (API) for shaker screens that describes and defines the maximum screen opening sizes via cut point testing, screen flow potential via conductance testing, and standard labeling requirements for a screen..

## Cut Point Testing (D100)

A standardized dry aluminum oxide sieve method which correlates particle sizes with ASTM test sieves to define the maximum particle size (D100) cut points, denoted with an equivalent API number. The test defines the cut point as the particle size in which one-hundred percent of the particles larger than the D100 separation are retained by the test screen. This test is not a performance indicator, rather, it is a way to characterize openings of the screen mesh.

## Conductance Testing

A standardized flow testing method which determines the ability of a fluid to flow through a screen at a pre-determined pressure drop, measured in kilodarcy per millimeter(kD/mm). A higher conductance value means fluid will pass through the screen more easily than a screen having a lower conductance value. The calculated value is analogous to permeability per unit thickness.

## Screen Standard Labeling

API RP 13C encourages industry compliance to international standards by requiring the application of a permanent tag or label to the screen that is visible and legible using set guidelines. Our screens are API Compliant. The part numbers are simply part numbers and have no reference to screen cut point.

## D100 Separation and API Screen Number

D100 separation µm	API Screen number
> 3 075,0 to 3 675,0	API 6
> 2 580,0 to 3 075,0	API 7
> 2 180,0 to 2 580,0	API 8
> 1 850,0 to 2 180,0	API 10
> 1 550,0 to 1 850,0	API 12
> 1 290 to 1 550,0	API 14
> 1 090 to 1 290,0	API 16
> 925,0 to 1 090,0	API 18
> 780,0 to 925,0	API 20
> 655,0 to 780,0	API 25
> 550,0 to 655,0	API 30
> 462,5 to 550,0	API 35
> 390,0 to 462,5	API 40
> 327,5 to 390,0	API 45
> 275,0 to 327,5	API 50
> 231,0 to 275,0	API 60
> 196,0 to 231,0	API 70
> 165,0 to 196,0	API 80
> 137,5 to 165,0	API 100
> 116,5 to 137,5	API 120
> 98,0 to 116,5	API 140
> 82,5 to 98,0	API 170
> 69,0 to 82,5	API 200
> 58,0 to 69,0	API 230
> 49,0 to 58,0	API 270
> 41,5 to 49,0	API 325
> 35,0 to 41,5	API 400
> 28,5 to 35,0	API 450
> 22,5 to 28,5	API 500
> 18,5 to 22,5	API 635

# Variety of Mesh Types

With the DURAFLO frame as a solid base, M-I SWACO offers four different mesh types, allowing operators to choose the most efficient mesh type for the job without sacrificing durability and fluid processing capacity.

## MG (Market Grade)

MG is our most basic mesh type, featuring a single layer cloth with heavy wire diameter and square openings. Because of the durable, heavy wire diameter, this mesh type is mainly used as scalping screens and provides excellent screen life.



## HC mesh type features fine wires with rectangular openings.

The two fine screening layers over a support cloth provides superior performance in blinding applications and yields excellent capacity with screen life equal to XL mesh. While the fine wire diameter provides excellent capacity, this mesh type has shorter screen life and lower separation efficiency compared to our other mesh types.

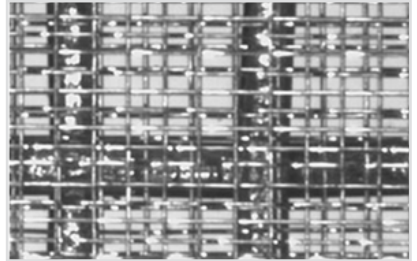

## Ultra-Fine (XL) screen

The Ultra-Fine (XL) screen has been specifically designed to cope with drilling sandstone formations, which typically present blinding problems using standard screen mesh types. Our XL mesh features two fine screening layers and a support mesh and Square openings with fine wire diameters offering improved capacity, screen life, and blinding resistance compared to TBC. The odd opening size distribution and movement between layers helps resist blinding.

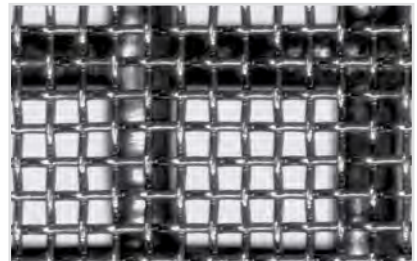

## Patented XR mesh

Rectangular openings, larger diameter wire combined with our patented cloth calendaring design gives XR mesh excellent capacity and the longest screen life in the industry. XR mesh coupled with DURAFLO technology allows best in class fluid-handling capacity. This high conductance results in reduced mesh loading when compared to traditional mesh types.





# DURAFLO Composite OEM and Replacement Screens



The composite evolution began with our first generation, patented, HIFLO screen. It was the first to use a grid made from a composite of high-strength plastic and glass, reinforced with high tensile strength rods.

Today's evolutionary composite DURAFLO screens deliver even longer screen life and greater ease in making repairs, giving way to an overall more robust product.

## Longer Screen Life

The composite frame design encompasses the "window pane" effect of incorporating an increased number of smaller panels, thereby evenly distributing mechanical stresses and containing mesh damage to small localized areas.

## Reduced Screen Weight

The DURAFLO composite screen weighs about the same as our first generation composite, HIFLO. However, it weighs up to 40% less than traditional metal framed screens. Lower screen weight gives way to enhanced shaker G-Force.

## Easy Screen Repair

The patented SNAP-LOK plug repair system reduces repair time to less than 2 minutes. By simply inserting a factory made plug, this system eliminates the need for cutting and gluing damaged cells. This equates to reduced rig time for solids control equipment service and maintenance.

## Features and Benefits

- Patented, composite frame design
- Available for M-I SWACO, Brandt<sup>^</sup>, Derrick<sup>^</sup>, and Axiom<sup>^</sup> brand shakers
- Featuring the "window pane" effect, has increased number of smaller flow panels for enhanced durability
- Consistent screen open area
- Less weight than metal-frame screens
- Featuring the SNAP-LOK repair system
- Composite screen offers chemical resistance and environmental degradation
- Consistently manufactured, rugged construction
- Increased operational life
- Lower overall screen costs due to fewer required replacements
- Quick and easy to repair
- Less downtime
- Resistant to rust and delamination caused by chemical and environmental exposure
- Improved QHSE considerations

<sup>^</sup>NOV Brandt is a mark of Varco I/P, Inc.  
<sup>^</sup>Derrick is a mark of Derrick Equipment Company  
<sup>^</sup>Axiom AX-1 is a mark of Axiom Process Ltd.

# DURAFLO Composite OEM Screens for M-I SWACO shakers

Simply stated, we've combined the industry's best available solids control equipment technology with its most optimized accessory, the composite screen. The high capacity composite screens from M-I SWACO are the most rugged, long lasting, and efficient screens available.

Composite screens are unique in the industry and provide chemical resistance and delamination to corrosive drilling fluids. Our patented technology offers significant fluid handling capacity, blinding resistance, drier solids discharge, and an overall larger net usable screen area. The precision molding process produces increased number of smaller, more precise panels.

Our integrated sealing mechanism creates an ultra-tight seal between the screen and bedding plane, thereby eliminating solids buildup and costly solids bypass. A cleaner mud = efficient drilling = reduced skin damage = enhanced production.

## Features and Benefits

- Composite material, resistant to chemical degradation
- Integrated Sealing Mechanism, eliminates bypass
- Easy installation/removal using patented interlocking system
- Light-weight
- Enhanced fluid handling capacity
- Co-molded Gasket Design
- Improved QHSE profile
- Easily Repairable with patented Snap-Lok technology, requiring no cure time
- Blinding Resistance



## For MONGOOSE series shakers

The DURAFLO for MONGOOSE Shakers (including MEERKAT) features unique wedge mechanism for screen locking. The composite construction combined with the efficient and easy locking mechanism eliminates solids bypass which give way to costly required fluid dilutions. In addition, it allows easy screen removal, repair, or replacement.

## For MD series shakers

The MD Shaker Series (MD-2 and MD-3) and Screens were designed in tandem, to take full advantage of the technology available through the use of composite materials, while maximizing shaker performance.

The DURAFLO for MD Series Shakers feature a novel self-latching design that maintains screen-to-screen seal. This allows screens to be removed as a unit instead of individually, with no tools required.

## For BEM series shakers

The DURAFLO OEM screen for M-I SWACO BEM-600<sup>†</sup> and BEM-650<sup>†</sup> shale shakers takes the best screen and matches it to the best balanced elliptical motion shakers on the market. Featuring a patented, composite frame design that holds up under virtually all drilling conditions, the screen delivers unsurpassed usable screen area. DURAFLO screens are available with HC, Ultra-Fine (XL) and XRMESH<sup>†</sup>, giving operators maximum screening flexibility.

# DURAFLO Composite Replacement Screens for Derrick<sup>^</sup> 500 series shakers



## For Derrick D500 shale shakers

Our newest innovation in our composite technology replacement screen offering is the D500 Composite Screen, designed to fit Derrick<sup>^</sup> FLC 500 brand shakers while eliminating the “horse-shoe” effect. The OEM, corrugated screen design promotes solids build up in troughs, giving way to excessive wear and must be run at elevated deck levels to utilize the additional screening area of peaks. Increased deck angles result in reduced screen life due to poor solids conveyance.

Our solution is the D500 C premium, flat panel design featuring our patented,

lightweight composite frame with glass filling and internal steel reinforcement structure designed to stay flat and parallel to the shaker bed, eliminating the horse-shoe effect which leads to increased dry beach, pre-mature screen wear, and screen blinding.

## Field-proven results

Recent field trials showed the D500 Flat Panel Composite to be superior in screen

life and performance efficiency. Given the nature of the drilled formation, we recommended an API 140 version of our patented D500-Composite screens in XR mesh. Testing proved the D500-Composite screens are capable of equivalent fluid handling capacity of the OEM’s corrugated screen with better liquid returns quality, further highlighting the flat panel design benefit. Even more, the D500’s flat panel decreased “dry beach” and “horseshoeing” phenomenon’s which promote premature screen blinding.

## Flat Panel Design Eliminates the “Horseshoe” Effect

The competitor’s OEM Shaker features a crowned deck to eliminate screen flexing under fluid load. However, this design results in reduced fluid handling and whole mud losses via bypass along the sides of the shaker bed. Additionally, shakers must be run at high deck angles to take full advantage of screening area, causing undue damage and costly repairs to shaker beds. Our lightweight, flat panel, composite technology eliminates the effects of having a crowned deck and resulting horseshoe phenomenon.

## Screen Life

The D500-Composite screens proved more than capable of handling the 8 ¾” drilled section in Southwest Oklahoma. It was observed that the M-I SWACO D500 composite flat panel showed greater resistance to screen mesh wear and gasket life vs. the OEM corrugated design. In addition, our composite flat panel showed superior screen life, reducing screen replacements by 60% after 30 days of production vs. the competitor. Even further, 30% total cell failure due to gasket and mesh failure.

## Screening Efficiency

While matching flow capacity and cuttings dryness, the D500-Composite screen exhibited a discard rate of 130% greater than the competitor. Test data also shows that while our screens processed more solid cuttings, the D500-Composite maintained better separation efficiency. The quality of the liquid stream is a key performance indicator in screening efficiency. The D500-Composite flat panel was shown to screen finer as indicated by a particle size analysis of the liquid returns stream. Our flat panel design, which eliminates the “horseshoe effect” and solids bypass, allowed for a particle size reduction of 20% in the liquid returns, showing a cleaner mud being returned to the system.

## Features

In addition, our D500 C features the following:

- High FLAT usable Area to increase fluids handling capacity
- Effective and Continuous cuttings contact to maintain fluid quality and reduce haul-off costs
- Eliminates horse-shoe effect while maximizing usable non-blanked area using the flat panel design
- Co-molded gasket to negate solids by-pass near the sealing mechanism
- Integrated handle design for easy handling, quick installations and change outs
- Increased Screen Life (no rust, corrosion, adhesives)
- Improved Solids Conveyance
- Lightweight for enhanced shaker G’s

<sup>^</sup>Derrick and FLC 500 are marks of Derrick Corporation.



# DURAFLO Composite Replacement Screens for Brandt<sup>^</sup> shakers



## For Brandt VSM 300 shale shakers

The new and improved DURAFLO replacement screen to fit the Brandt VSM 300<sup>^</sup> brand shaker takes the best screen for this shale shaker to the next level of performance. This screen uses a new frame design that features several improvements over original DURAFLO screens. It is lighter, more easily repaired, promotes longer screen life and is easier to remove. DURAFLO screens are available with TBC, Ultra-Fine (XL) and XR MESH, giving operators screening flexibility in addition to an overall-improved product.

## For NOV Brandt Cobra shakers

The DURAFLO<sup>+</sup> Composite Replacement Screens from M-I SWACO, for the National Oilwell Varco (NOV) Brandt Cobra<sup>^</sup>, King Cobra<sup>^</sup> and LCM-3D<sup>^</sup> shakers, provide greatly improved performance and reliability over traditional metal-backed screens.

The design features a soft gasket and allows the screen to be removed and reinstalled while maintaining a reliable sealing mechanism. These improvements give way to improved screen life and screen costs per well, resulting in significant operator savings.

## Field-proven results

Recent field trials confirm improved performance of DURAFLO Composite Screens via three key Performance Indicators.

### Screen replacement

Each time the front screen was pulled for checking or changeout, the new interlocking joint between the DURAFLO front and back screens automatically pulled the back panel, eliminating the need for a screen hook. When the front screen was pushed in during replacement, it automatically created a seal with the rear screen. Screens were checked or changed out more than 25 times, performing consistently without any operational issues. It was also noted that the 16% weight reduction in the new DURAFLO screens assisted in the easy removal of the screens from the shaker (compared to previous DURAFLO composite screens).

### Screen repairs

Utilizing the new SNAP-LOK plug-repair system, three plugs were installed in less than two minutes on one of the rear DURAFLO screens – two at the back and one in the middle. The new plug simply snapped in from the rear of the screen and created a good seal so no solids could penetrate the damaged panel. The screens were reinstalled and put

to use immediately. The SNAP-LOK plugs were checked regularly and the screens were removed after 22 hrs with all three plugs still firmly in place. Another plug was installed later during the test on a partially damaged screen. This screen was removed after approximately 20 hrs with the plug still snugly in place.

### Screen life

Two identical shakers were fitted with two DURAFLO Ultra-Fine (XL) 175 mesh screens on the left side of the shaker bed, and with two HIFLO Ultra-Fine 175 mesh screens on the right. Both shakers used 20 mesh scalping screens and operated at the same G-force. During testing, all screens were checked every 4 hrs for damage. As a result of the use of a downhole turbine during the interval, a large amount of fine cuttings was generated and introduced to the shakers. Over the period required to drill the 8 1/2 in. interval, a total of seven DURAFLO and nine HIFLO screens were used. The HIFLO screens lasted an average of 51 hrs, while the average life of the DURAFLO screens was recorded at 65 hrs - an improvement of 27%.

## Features and Benefits

- Lighter weight vs traditional OEM equipment
- 5.5 ft<sup>2</sup> of precision molded NBA
- Co-molded gasket, eliminating bypass
- No Crown Rubbers required
- Corrosion resistant

## New interlocking screen joint

- Patent-pending, interlocking joint, eliminating the need for hooks.
- To remove the rear screen, simply pull the front screen and both front and rear screens will be removed together
- When replacing, insert the screens separately
- The new joint reduces changing time to less than two minutes, making it easy to change all screens during a connection if necessary

<sup>^</sup>NOV Brandt, VSM 300, Cobra, King Cobra and LCM-3D are marks of Varco I/P, Inc.  
<sup>+</sup>Results obtained testing screens for the MONGOOSE PT shaker.



# DURAFLO Composite Replacement Screens for Axiom<sup>^</sup> shakers

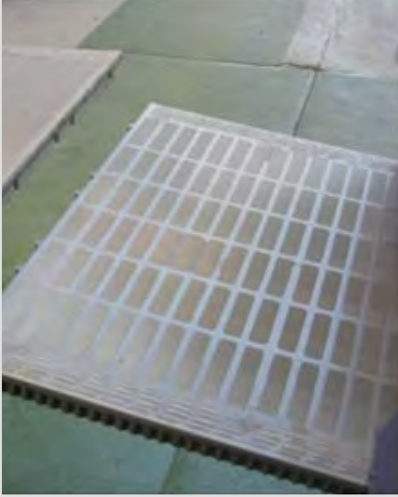

## For Axiom AX-1 shakers

With the M-I SWACO DURAFLO Axiom AX-1<sup>^</sup> screen, the OEM metalback screen is replaced with a rigid, lightweight composite material and does not use the sliding steel tray for support. DURAFLO screens have a patented design that is unique to our industry and has many field-proven Benefits.

The DURAFLO AX-1 is a composite replacement screen for Axiom brand shakers. It features the patented design utilizing a polymer frame with the steel reinforcing structure. In addition, it features a specialized gasket made of softer, more pliable material

which is co-molded onto the leading edges of the composite frame. This provides a soft but durable seal between the shaker bed and screens. The design also features the easy latching system which joins screens during operation and allows easy removal without the need for additional tools and accessories.

## Field Proven Results

Recent GOM and Brazil Field Trial data confirms superior DURAFLO performance in regard to screen life, separation efficiency, cuttings conveyance, enhanced shaker G-Force.

## Screen Consumption

The highly supported, durable composite design outperformed the competitor's OEM in the Gulf of Mexico, by reducing screen consumption by 25% during the 8½" oil production interval using synthetic oil based drilling fluid. The flat panel design allowed excellent fluids handling capacity without the need for costly screen change-outs.

## Cuttings Conveyance

Using our patented flat-panel design, our DURAFLO AX-1 was able to decrease cuttings conveyance rates by <sup>^</sup>23% while maintaining superior cuttings dryness. Retort analysis of the discharge stream indicated an improved mud recovery of nearly 40% compared to the competitor's OEM. Bottom line – we process cuttings faster, minimizing screen damage; and better, allowing the operator to recover more costly drilling fluid to the active system.

## Enhanced Shaker G's

The lightweight composite material used for our DURAFLO AX-1 reduces screen weight significantly, allowing for higher shaker

## Features and Benefits

### Improvements over the metal-backed OEM screens

- **Increased g-forces.** Use of a heavy, sliding steel support tray is no longer necessary, which improves overall shaker G-force
- **Reduced Screen Weight :** M-I SWACO composite screens weigh 8.0 kg each, so 18 screens to dress out the shaker weigh a total of 144 kg
  - The total screen assembly weight of M-I SWACO DURAFLO AX-1 screens is 59% less than that of the metal OEM screens and trays
- **Quick screen changes.** Easy to use push-and-lock latches make screen changes fast and easy
- **Corrosion-resistant.** The polypropylene frame coupled with the stainless steel mesh of the DURAFLO Axiom AX-1 screen yields it resistant to chemical and environmental degradation. Meanwhile, metal-backed screens are susceptible to chemical and

environmental degradation due to the carbon steel plate used in their construction

- **Consistent tension.** The composite screen manufacturing process ensures the proper tension is applied to each layer of mesh, and that the mesh and frame have a consistent bond across the screen. This tight control of mesh tension reduces fatigue of screen wires and improves screen life
- **Reliability.** The mesh is bonded directly to the frame and thereby, improves the life of the screen
- **Non-blanked area.** Equivalent non-blanked area of OEM screen, of 2.8 ft<sup>2</sup>
- **Choose from XL<sup>†</sup>, HC<sup>†</sup>, and XR<sup>†</sup> meshes.** Your M-I SWACO representative will help you match the most effective mesh to your application

G-Forces and minimizes shaker basket wear. The resulting 10% increase in shaker G-Force allows better conveyance

as noted. Screen weight was reduced by 59% vs. the competitor's OEM, shedding over 450 lbs!

<sup>^</sup>Axiom AX-1 is a mark of Axiom Process Ltd.

<sup>†</sup>Results obtained testing screens for the MONGOOSE PT shaker.

# M-I SWACO Commodity Screens Portfolio



M-I SWACO screens portfolio also includes both commodity pretensioned and hookstrip type metal back replacement screens and plastic back, hookstrip screens.

## **Metal Back OEM and Replacement Screens**

Our lightweight, repairable hookstrip-metal back offerings include replacements for Derrick FLC 500, featuring 1 to 3 layers of mesh with a metal grid and hook strips. Our pretensioned metal back offerings include M-I SWACO, Brandt (Cobra, King Cobra, LCM3D, D285P/380P), Fluid Systems (Black Thunder, 29x42), Kemtron (KPT 28), and Vortex Fluid Systems (Orbital), featuring 1 to 3 layers of repairable, tensioned mesh bonded directly to a metal grid and rigid frame, eliminating the "horseshoe" effect.

## **Plastic Back OEM and Replacement Screens**

Our lightweight, repairable hookstrip-plastic back offerings include M-I SWACO (ALS, BEM-3, Brandt (LCM 2D, LM3, 4X5), Derrick (FLC 300, FLC 2000), Kemtron (KDX), Triton (Triton), and Vortex Fluid Systems (Orbital)), featuring 1 to 3 layers of mesh with a plastic grid and hookstrips.

While not our premium offering, our commodity screens come with the same exceptional commitment to quality and API compliance. Customers have the option to customize their operations without compromising quality, using our diverse portfolio of premium and commodity screens.

# API Compliant OEM and Replacement Screens Summary

	DURAFLO® Composite	Plastic Back Hookstrip	Metal Back (Flat Panel)	Unbonded Hookstrip	Metal Back (Hookstrip)	Pre-tensioned	Mesh Type	Screen Dimensions (inches)
<b>OEM SCREENS</b>								
M-I SWACO								
ALS <sup>1</sup>		✓					XL, XR	45.25" x 47.75"
BEM-3 <sup>1</sup>		✓		✓			MG, XL, XR	45.5" x 35.5"
BEM-6 <sup>1</sup>	✓						MG, HC, XL, XR	36 x 27.5
MD-2 <sup>1</sup> /MD-3 <sup>1</sup>	✓						MG, HC, XL, XR	24.49" x 25.8"
MONGOOSE <sup>1</sup> /MEERKAT <sup>1</sup> Series	✓		✓				MG, HC, XL, XR	23" x 45.875"
2x6				✓			MG	24.25" x 72"
4x3				✓			MG	45.25" x 47.75"
<b>REPLACEMENT SCREENS</b>								
AXIOM								
ALS	✓		✓				MG, HC, XL, XR	27" x 24"
Brandt / NOV / Rigtech								
Cobra	✓		✓				HC, XL, XR	25" x 49.3125"
King Cobra	✓		✓				HC, XL, XR	25" x 49.3125"
LCM3D	✓		✓				HC, XL, XR	25" x 49.3125"
ATL1000	✓		✓				HC, XL, XR	25" x 49.3125"
4X3				✓			MG	45.25" x 36"
LCM2D/LM3		✓					XL, XR	45.25" x 36"
4X5		✓		✓			MG, XL	48.5" x 59.5"
D285P/380			✓				XL, XR	28" x 46.5"
VSM 100	✓			✓		✓	MG, HC, XL, XR	25" x 36.25"
VSM 300	✓					✓	MG, HC, XL, XR	27" x 35.5"
Derrick								
FLC 300		✓					XL, XR	33.25" x 27.5"
FLC 500	✓				✓		XL, XR	41.5" x 27.5"
FLC 2000		✓	✓	✓			MG, XL, XR	41.125" x 27.5"
Fluid Systems								
Black Thunder			✓				XL, XR	36" x 42"
29x42			✓				MG, XL, XR	29" x 42.1875"
Kemtron								
KDDX				✓			MG	30" x 72"
KDX		✓					XL, XR	28" x 48"
KPT28			✓				XL, XR	28.25" x 49.25"
Tri-Flo								
2X3				✓			MG	24.5" x 36"
4x3				✓			MG	48.5" x 36"
Triton								
Triton		✓					XL, XR	48.5" x 28.5"
Vortex Fluid Systems								
Orbital Vortex		✓	✓		✓		XL, XR	46" x 31.875"

# CD 500 HV Centrifuge



The CD 500 High Volume (HV) centrifuge is a high-powered centrifuge designed for exceptional low gravity solids (LGS) separation and barite recovery in operations where large feed rates are a requirement.

The CD 500 HV centrifuge has been designed to process large volumes of fluids, improve barite recovery and produce solids that meet environmental regulations for disposal. Automatic PLC monitoring and adjustment compensates for varied drilling conditions and maintains maximum solids/fluids separation throughout the drilling operation.

The CD 500 HV centrifuge recovers valuable drilling fluid and barite while reducing the total volume of drilling waste that must be transported for injection, disposal or remediation.

By recovering more fluid and producing drier cuttings with a smaller volume, the CD 500 HV centrifuge helps operators reduce their drilling waste and disposal volumes.

## Features

### Performance

- Quasi-Axial scroll
- High bowl speed
- Double feed chamber
- Open ended and slotted feed tubes
- Oil forced lubricated main bearings
- Variable bowl, scroll and pump speed
- Split pillow blocks
- PLC control
- Stainless steel rotating assembly
- Perfectly balanced rotating assembly
- Tungsten carbide tiles (scroll)

### Safety

- Vibration sensor
- Torque limiter
- Micro switches on vessel and guards
- Bearing temperature sensors
- Pressure sensors <sup>(1)</sup>
- Hydraulic oil temperature sensor <sup>(1)</sup>
- Speed sensors <sup>(1)</sup>

(1) Only on Fully Hydraulic Drive types

## Benefits

### Performance

- Quasi-Axial scroll provides an increased flow area which minimizes the turbulence for an improved separation efficiency and a high fluid handling capacity
- High bowl speed assures a high G-Force, solids removal efficiency, finest cut points and a high clarification capacity
- Double feed chamber and open ended/slotted feed tubes assure better configuration for barite recovery or LGS removal
- Reduced bearing wear and maintenance requirements
- Complete control of G-Force for improved separation efficiency
- Split pillow blocks for increased protection against contamination, extended material life and easier maintenance
- Programmable Logic Controller (PLC) provides continuous monitoring and automatic shut-down of all critical parameters while providing automatic control to avoid centrifuge plugging



# Technical specifications for the CD-500 HV Centrifuge

**CD 500 HV VFD**  
**CD 500 HV FHD**

**CD 500 HV SL VFD**  
**CD 500 HV SL FHD**

All dimensions are expressed in inches (millimeters).

## Specifications

### Performance

- Hydraulic Capacity: 674 GPM (2,551 LPM)
- Operating Speed: 3,200 rpm
- G-Force: 2,656 G
- Sigma Value: 49,589 ft<sup>2</sup> (4,607 m<sup>2</sup>)
- Solids Discharge: 53 GPM (12.0 m<sup>3</sup>/h)

### Rotating Assembly

- Bowl Diameter: 18.6 in. (472 mm)
- Bowl Length: 67.5 in. (1,715 mm)
- Pond Depth: 2.2, 2.6, 3.0 in. (56, 66, 76 mm)
- Scroll Type: Single Lead Quasi Axial Flow
- Scroll Pitch: 5.12 in. (130 mm)
- Main Bearings: Oil Lubricated
- Internal Bearings: Grease Lubricated
- Feed Tube: Open Ended [LGS Removal] Slotted [Barite Recovery]

### Rotating Assembly Material

- Bowl: Stainless Steel Duplex A890
- Scroll: Stainless Steel Duplex A890 AISI 304
- Scroll Flights: Tiles; Tungsten Carbide
- Discharge Bushings: Tungsten Carbide

### Gearbox

- Type: Planetary [Model; ZG 3700/10]
- Gear Ratio: 80:1
- Torque, maximum: 6,269 ft-lb (8,500 Nm)
- Differential Range: 1 to 40 rpm
- Weight: 474 lbs (215 Kg)

### Nozzle Schedule

- Liquid Discharge: 8 in. Victaulic
- Solids Discharge: 31.9 x 17.7 in. (810 x 450 mm)
- Feed Tube: 2 in. [ANSI B 16.5]

### VFD Type

- Power: 400/460 V - 50/60 Hz, 3 Phase
- Main Drive Motor: 100 Hp (75 kW)
- Back Drive Motor: 30 Hp (22 kW)

### FHD Type

- Power: 400/460 V - 50/60 Hz, 3 Phase
- Main Drive Motor: 120 Hp (90 kW)
- Hydraulic Pump: Variable Displacement Pump

### Certification

- CD 500 HV VFD: ATEX CE Ex II 2G c b IIB T3 or Class I, Division 1 hazardous areas for USA and Canada
- CD 500 HV FHD: ATEX CE Ex II 2G c b IIB T3
- CD 500 HV SL VFD: ATEX CE Ex II 2G c b IIB T3 or Class I, Division 1 hazardous areas for USA and Canada
- CD 500 HV SL FHD: ATEX CE Ex II 2G c b IIB T3

## Dimensions and Weights

	X	Y	Z	Weight
■ CD 500 HV VFD:	155.4 in. (3,946 mm)	47.8 in. (1,215 mm)	79.5 in. (2,020 mm)	11,023 lbs (5,000 Kg)
■ CD 500 HV FHD:	163.2 in. (4,146 mm)	90.2 in. (2,290 mm)	87.4 in. (2,220 mm)	14,330 lbs (6,500 Kg)

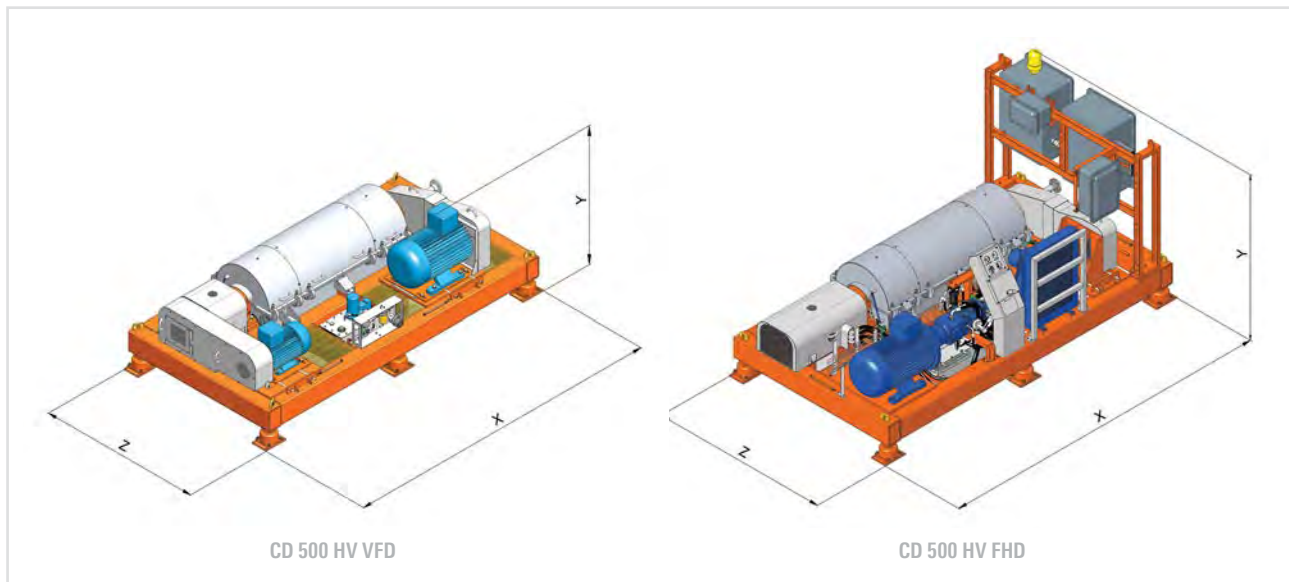

# Technical specifications for the CD-500 HV Centrifuge

CD 500 HV VFD  
 CD 500 HV FHD

CD 500 HV SL VFD  
 CD 500 HV SL FHD

All dimensions are expressed in inches (millimeters).

## Specifications

### Dimensions and Weights (Continued)

	X	Y	Z	Weight
■ CD 500 HV SL VFD	163.3 in. (4,149 mm)	76.1 in. (1,934 mm)	48.4 in. (1,230 mm)	11,023 lbs (5,000 Kg)
■ CD 500 HV SL FHD [Centrifuge Module]	157.9 in. (4,010 mm)	76.3 in. (1,937 mm)	47.6 in. (1,210 mm)	10,417 lbs (4,725 Kg)
■ CD 500 HV SL FHD [Hydraulic Module]	129.9 in. (3,300 mm)	90.2 in. (2,290 mm)	68.5 in. (1,740 mm)	6,989 lbs (3,170 Kg)
■ VFD Control Panel [ATEX]	41.3 in. (1,050 mm)	98.4 in. (2,500 mm)	82.7 in. (2,100 mm)	3,527 lbs (1,600 kg)
■ VFD Control Panel [UL]	48.0 in. (1,219 mm)	90.0 in. (2,286 mm)	102.0 in. (2,591 mm)	2,640 lbs (1,198 kg)

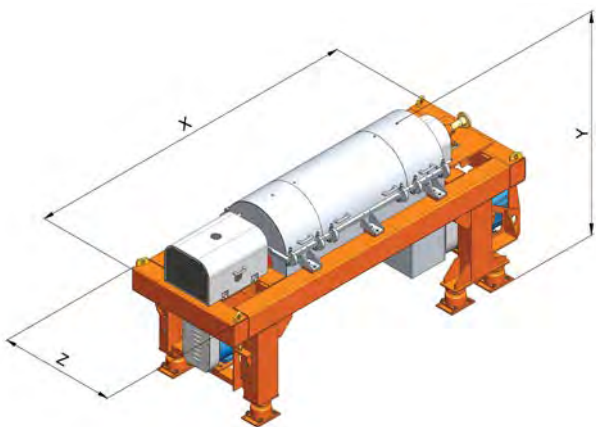

CD 500 HV SL VFD

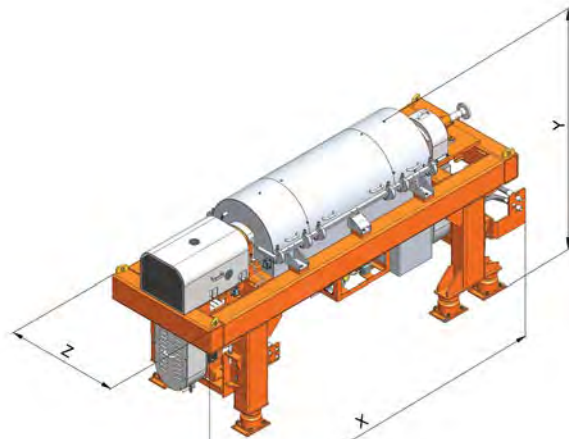

CD 500 HV SL FHD  
[Centrifuge Module]

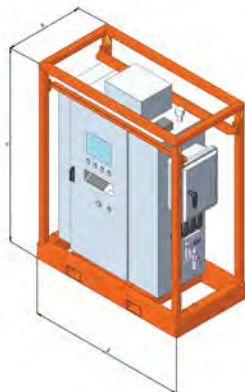

VFD Control Panel

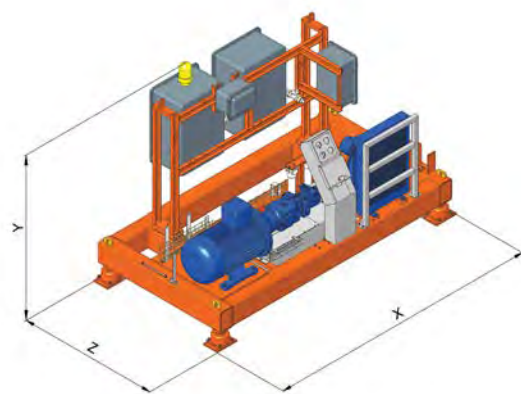

CD 500 HV SL FHD  
[Hydraulic Module]

# 518 HV Centrifuge



The 518 High Volume (HV) centrifuge is a unit which replaces the operation of two standard 518 centrifuges combined through an increased fluid handling capacity and improved solids separation.

The 518 HV centrifuge is designed to handle higher fluid processing rates by providing more power and improving the fluid flow in and out of the machine.

Increasing the available power for the main (50 Hp) and back drive (15 Hp) allows more fluid to be fed into the bowl while providing the necessary torque to remove the increased solids load resulting from the higher feed rate.

The unit also has an improved fluid accelerator to reduce turbulence and bring the fluid velocity (both magnitude and direction) up to the bowl rotating speed and direction as quick as possible, thus reducing the energy consumed for fluid acceleration and reserving more energy for solids conveyance.

The unit contains a Quasi-Axial flow scroll which increases the flow area inside the bowl thus reducing the fluid velocity and hence, the onset of turbulence.

## Features

### Performance

- Quasi-Axial scroll
- Tungsten carbide tiles (scroll)
- High bowl speed
- Variable bowl and scroll speed<sup>(1)</sup>
- Fixed bowl and differential speed<sup>(2)</sup>
- Variable feed pump speed
- Split pillow blocks
- Stainless steel rotating assembly
- Perfectly balanced rotating assembly
- PLC control<sup>(1)</sup>

### Safety

- Vibration sensor
- Torque limiter
- Micro switches on vessel and guards
- Bearing temperature sensors<sup>(1)</sup>
- Pressure sensors<sup>(3)</sup>
- Hydraulic oil temperature sensor<sup>(3)</sup>
- Speed sensors<sup>(3)</sup>

(1) Not applicable to Fixed Drive

(2) Only applicable to Fixed Drive

(3) Only on Fully Hydraulic Drive types

## Benefits

### Performance

- Quasi-Axial scroll provides an increased flow area which minimizes the turbulence
- Increased flights wear resistance thereby reducing maintenance requirements
- High bowl speed assures a high G-Force, solids removal efficiency percentage and finest cut points.
- Complete control of G-Force and differential settings for improved separation efficiency
- Six bowl speed/differential combinations on fixed drive units for enhanced simplicity and efficiency
- Split pillow blocks for increased protection against contamination, extended material life and easier maintenance
- Highly corrosion resistant
- Minimal vibration and noise emissions
- Programmable Logic Controller (PLC) provides continuous monitoring and automatic shut-down of all critical parameters while providing automatic control to avoid centrifuge plugging<sup>(1)</sup>

# Technical specifications for the 518 HV Centrifuge

## 518 HV (Fixed Drive) 518 HV VFD

## 518 HV FHD 518 HV SL VFD

## 518 HV SL FHD

All dimensions are expressed in inches (millimeters).

### Specifications

#### Performance

- Hydraulic Capacity: 248 GPM (939 LPM)
- Operating Speed: 3,200 rpm
- G-Force: 1,975 G
- Sigma Value: 24,326 ft<sup>2</sup> (2,260 m<sup>2</sup>)
- Solids Discharge: 27 GPM (6.1 m<sup>3</sup>/h)

#### Rotating Assembly

- Bowl Diameter: 13.9 in. (353.1 mm)
- Bowl Length: 57.5 in. (1,461.1 mm)
- Pond Depth: 2.3, 2.42, 2.54 in. (58.5, 61.5, 64.5 mm)
- Scroll Type: Single Lead Quasi Axial Flow
- Scroll Pitch: 4.31 in. (109.5 mm)
- Main Bearings: Grease Lubricated
- Internal Bearings: Grease Lubricated
- Feed Tube: Open Ended

#### Rotating Assembly Material

- Bowl: Stainless Steel Duplex A890
- Scroll: Stainless Steel Duplex A890 AISI 304
- Scroll Flights: Tiles; Tungsten Carbide
- Discharge Bushings: Tungsten Carbide

#### Gearbox

- Type: Planetary
- Gear Ratio: 57:1
- Torque, maximum: 2,531 ft-lb (3,432 Nm)
- Differential Range:
  - Fixed Drive: 10 to 79 rpm
  - VFD: 1 to 55 rpm
  - FHD: 1 to 80 rpm
- Weight: 159 lbs (72 Kg)

#### Nozzle Schedule

- Liquid Discharge: 8 in. Victaulic
- Solids Discharge: 21.0 x 13.8 in. (530 x 350 mm)
- Feed Tube: 2 in. NPT [Male Connection]

#### Fixed Drive Type

- Power: 400/460 V - 50/60 Hz, 3 Phase
- Main Drive Motor: 50 Hp (37 kW)
- Back Drive Motor: 15 Hp (11 kW)

#### VFD Type

- Power: 400/460 V - 50/60 Hz, 3 Phase
- Main Drive Motor: 50 Hp (37 kW)
- Back Drive Motor: 15 Hp (11 kW)

#### FHD Type

- Power: 400/460 V - 50/60 Hz, 3 Phase
- Main Drive Motor: 60 Hp (45 kW)
- Hydraulic Pump: Variable Displacement Pump

#### Certification

- 518 HV (Fixed Drive): ATEX CE Ex II 2G c IIB T3 or Class I, Division 1 hazardous areas for USA and Canada
- 518 HV VFD: ATEX CE Ex II 2G c IIB T3 or Class I, Division 1 hazardous areas for USA and Canada
- 518 HV FHD: ATEX CE Ex II 2G c b IIB T3
- 518 HV SL VFD: ATEX CE Ex II 2G c IIB T3 or Class I, Division 1 hazardous areas for USA and Canada
- 518 HV SL FHD: ATEX CE Ex II 2G c b IIB T3

Specifications continued on next page.



# Technical specifications for the 518 HV Centrifuge

518 HV (Fixed Drive)  
518 HV VFD

518 HV FHD  
518 HV SL VFD

518 HV SL FHD

All dimensions are expressed in inches (millimeters).

## Specifications

### Dimensions and Weights

	X	Y	Z	Weight
■ 518 HV (Fixed Drive)	119.0 in. (3,023 mm)	53.3 in. (1,353 mm)	70.0 in. (1,778 mm)	6,173 lbs (2,800 Kg)
■ 518 HV VFD	119.0 in. (3,023 mm)	34.9 in. (887 mm)	70.0 in. (1,778 mm)	5,291 lbs (2,400 Kg)
■ 518 HV FHD	142.0 in. (3,608 mm)	70.1 in. (1,780 mm)	78.7 in. (2,000 mm)	10,141 lbs (4,600 Kg)
■ 518 HV SL VFD	132.6 in. (3,368 mm)	65.9 in. (1,674 mm)	39.4 in. (1,000 mm)	5,855 lbs (2,656 Kg)

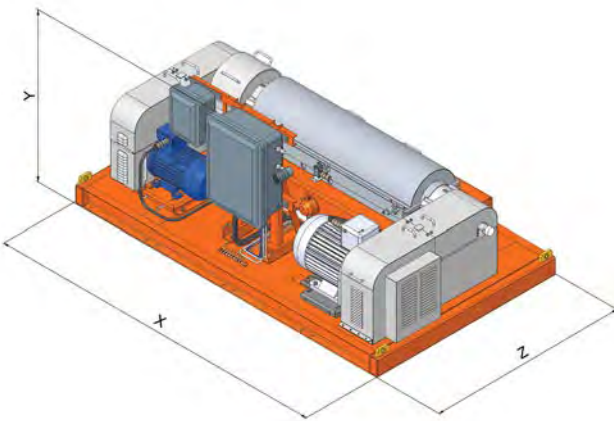

518 HV (Fixed Drive)

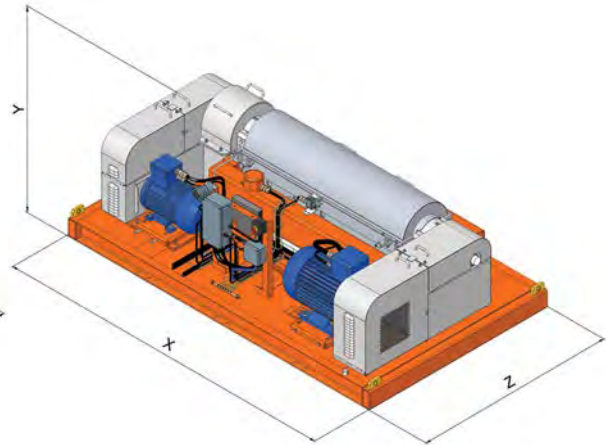

518 HV VFD

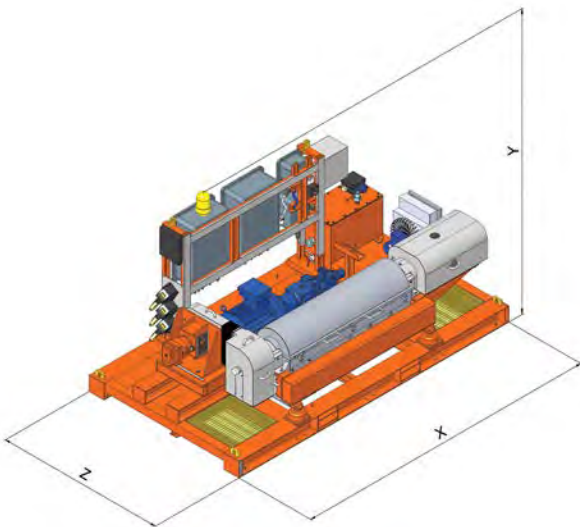

518 HV FHD

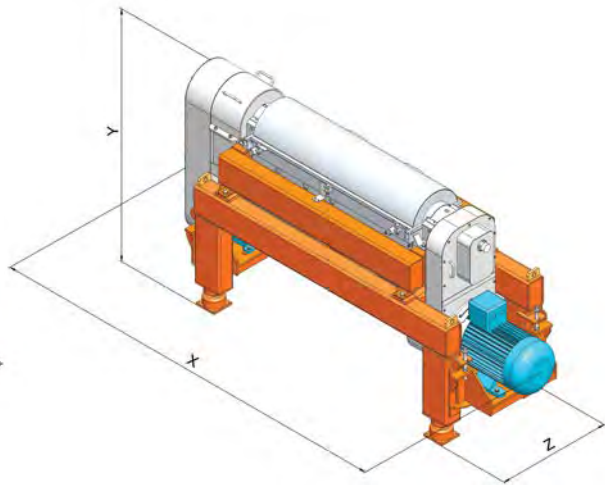

518 HV SL VFD

# Technical specifications for the 518 HV Centrifuge

518 HV (Fixed Drive)  
518 HV VFD

518 HV FHD  
518 HV SL VFD

518 HV SL FHD

All dimensions are expressed in inches (millimeters).

## Specifications

### Dimensions and Weights (Continued)

	X	Y	Z	Weight
■ 518 HV SL FHD [Centrifuge Module]	130.5 in. (3,314 mm)	59.0 in. (1,499 mm)	37.0 in. (940 mm)	4,850 lbs (2,200 Kg)
■ 518 HV SL FHD [Hydraulic Module]	96.5 in. (2,450 mm)	79.7 in. (2,025 mm)	50.8 in. (1,290 mm)	5,512 lbs (2,500 Kg)
■ VFD Control Panel (ATEX)	41.3 in. (1,050 mm)	98.4 in. (2,500 mm)	82.7 in. (2,100 mm)	3,527 lbs (1,600 kg)
■ VFD Control Panel (UL)	48.0 in. (1,219 mm)	90.0 in. (2,286 mm)	102.0 in. (2,591 mm)	2,640 lbs (1,198 kg)

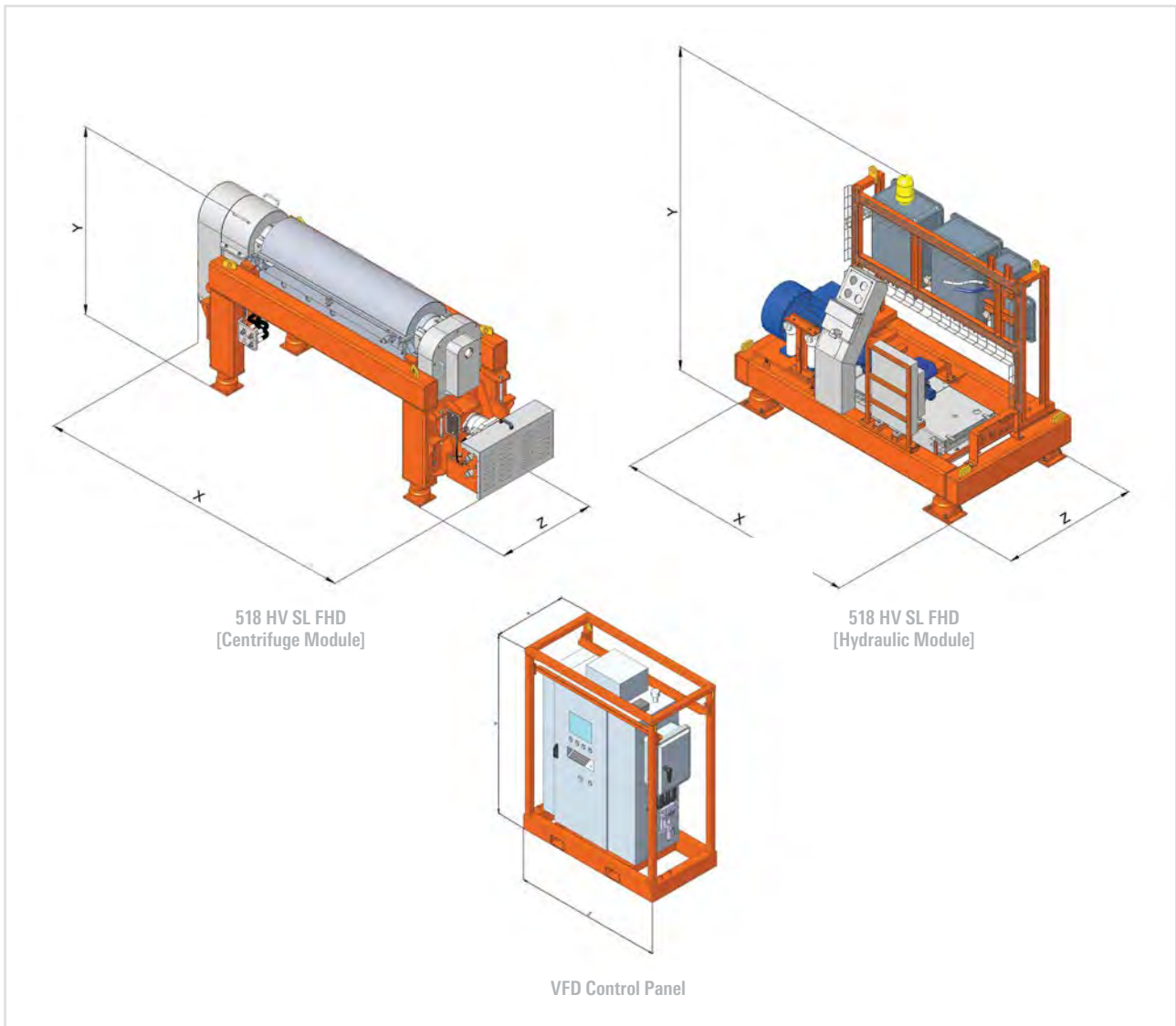

# CD 250 Centrifuge



The CD 250 centrifuge is the smallest centrifuge in the fleet characterized by an easy control system, a rugged design and a low installation/removal time. The unit recovers valuable fluids while reducing the total volume of waste.

In spite of the compact design, it delivers a high clarification capacity thanks to the high G-Force created.

To minimize the footprint and weight the unit is equipped with a single 20 Hp motor. An innovative system of belts and pulleys drives the sun-wheel shaft and provides the necessary torque therefore eliminating the need for a second motor. As the unit only requires a single motor the power consumption is kept to a minimum.

## Features

### Performance

- Smallest footprint
- Lowest weight
- Fixed bowl and differential speed
- High bowl speed
- Easy control system
- Split pillow blocks
- Hard facing on flights
- Adjustable pond dams and variable pump speed
- Stainless steel rotating assembly
- Perfectly balanced rotating assembly

### Safety

- Vibration sensor
- Torque limiter
- Micro switches on vessel and guards

## Benefits

### Performance

- Portable and rugged design
- Minimal installation and removal time
- Bowl speed (4,000 rpm) and differential (26 rpm) are set to maximize LGS removal in HDD/ Mining projects
- High bowl speed assures a high G-Force, solids removal efficiency percentage and finest cut points
- Minimized equipment operator skill requirements
- Split pillow blocks for increased protection against contamination, extended material life and easier maintenance
- High flights wear resistance thereby reducing maintenance requirements
- Adjustable pond dams and variable pump speed allow for adjustment of the retention time and subsequent efficiency
- Highly corrosion resistant
- Minimal vibration and noise emissions

# Technical specifications for the CD 250 Centrifuge

## CD 250 Fixed Drive

All dimensions are expressed in inches (millimeters).

### Specifications

#### Performance

- Hydraulic Capacity: 83 GPM (314 LPM)
- Operating Speed: 4,000 rpm
- G-Force: 2,191 G
- Sigma Value: 13,326 ft<sup>2</sup> (1,238 m<sup>2</sup>)
- Solids Discharge: 11 GPM (2.5 m<sup>3</sup>/h)

#### Rotating Assembly

- Bowl Diameter: 10.0 in. (253 mm)
- Bowl Length: 37.1 in. (941.5 mm)
- Pond Depth: 0.95, 1.14, 1.44 in. (24, 29, 36.5 mm)
- Scroll Type: Single Lead Radial Flow
- Scroll Pitch: 3.94 in. (100 mm)
- Main Bearings: Grease Lubricated
- Internal Bearings: Grease Lubricated
- Feed Tube: Slotted

#### Rotating Assembly Material

- Bowl: Stainless Steel Duplex A890
- Scroll: Stainless Steel AISI 304
- Scroll Flights: Castolin Eutalloy SF hard facing
- Discharge Bushings: Tungsten Carbide

#### Gearbox

- Type: Planetary [Model; ZG 2400/10]
- Gear Ratio: 60:1
- Torque, maximum: 1,475 ft-lb (2,000 Nm)
- Differential Range: 26 rpm
- Weight: 128 lbs (58 Kg)

#### Nozzle Schedule

- Liquid Discharge: 3.9 x 3.2 in. (100 x 80 mm)
- Solids Discharge: 16.3 x 10.6 in. (413 x 268 mm)
- Feed Tube: 1 in. [WN RF ANSI 150 lb]

#### Fixed Drive Type

- Power: 400/460 V - 50/60 Hz, 3 Phase
- Main Drive Motor: 20 Hp (15 kW)

#### Certification

- CD 250 Fixed Drive:
  - CE Marked Only (Standard)
  - CE ATEX, Zone 1 (Optional)

### Dimensions and Weights

	X	Y	Z	Weight
■ CD 250 Fixed Drive:	81.8 in. (2,077 mm)	46.7 in. (1,187 mm)	31.5 in. (799 mm)	2,646 lbs (1,200 Kg)
■ CD 250 Fixed Drive Control Panel:	45.3 in. (1,150 mm)	61.0 in. (1,550 mm)	20.1 in. (510 mm)	551 lbs (250 Kg)

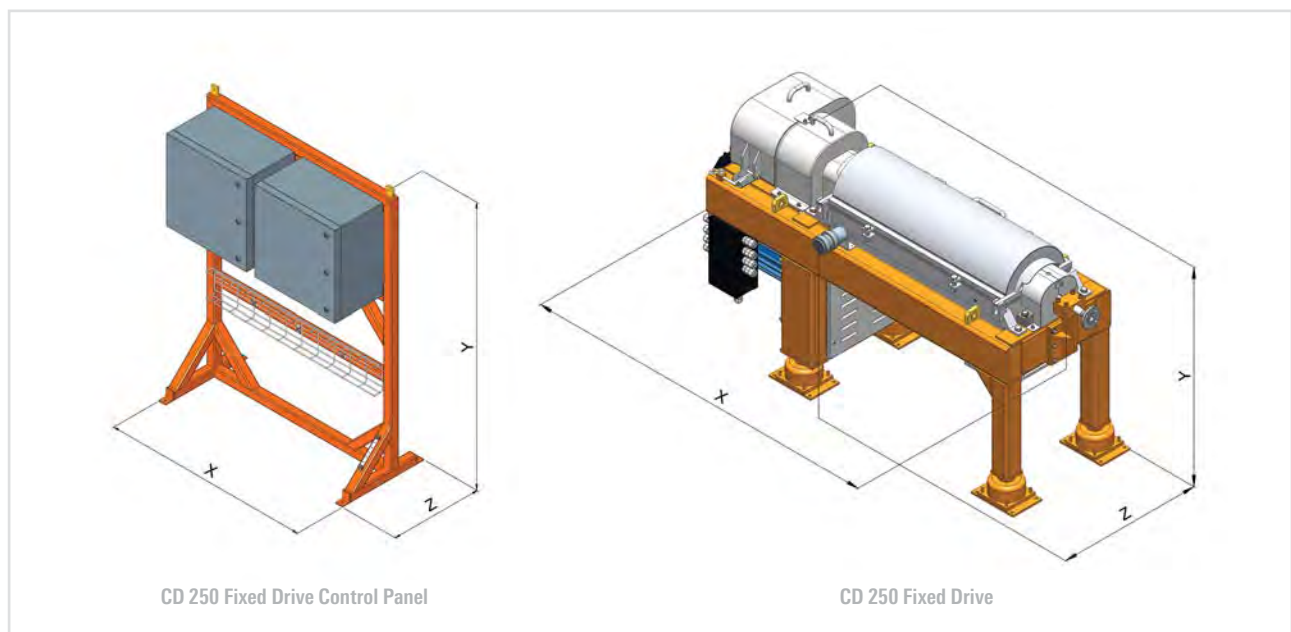

CD 250 Fixed Drive Control Panel

CD 250 Fixed Drive



# 414 Centrifuge



The 414 centrifuge is engineered to deliver high performance at low operating costs for both oilfield and industrial applications. This highly efficient decanting centrifuge recovers 95 percent of barite and returns it to the active system, while rejecting finer, low-gravity solids. The advanced design of the stainless steel bowl and scroll maintains an even layer of conveyed solids for more uniform separation and maximum solids-control efficiency.

The 414 centrifuge has a 14-in. diameter and 34-in length (353-mm x 860-mm) stainless steel bowl and scroll assembly. The variable speed main drive is v-belt driven through a torque converter by a 25 Hp, explosion-proof, electric motor. The main drive bowl speeds are easily changed with the variable-step sheave arrangement. The differential or back drive is v-belt driven by a 10 Hp, explosion-proof, and electric motor. The differential speed of the scroll can be adjusted from 10 to a maximum of 79 rpm.

## Features

### Performance

- Small ratio of bowl length to diameter (Lambda ratio)
- Fixed bowl and differential speed
- Easy control system
- Split pillow blocks
- Hard facing on flights
- Adjustable pond dams and variable pump speed
- Stainless steel rotating assembly
- Perfectly balanced rotating assembly

### Safety

- Vibration sensor
- Torque limiter
- Micro switches on vessel and guards

## Benefits

### Performance

- Recovers up to 95% of barite while rejecting finer low gravity solids
- Compact unit with light overall weight
- Six bowl speed/differential combinations on fixed drive units for enhanced simplicity and efficiency
- Minimized equipment operator skill requirements
- Split pillow blocks for increased protection against contamination, extended material life and easier maintenance
- Increased flights wear resistance thereby reducing maintenance requirements
- Adjustable pond dams and variable pump speed allow for adjustment of the retention time and subsequent efficiency
- Highly corrosion resistant
- Minimal vibration and noise emissions

# Technical specifications for the 414 Centrifuge

## 414 Fixed Drive

All dimensions are expressed in inches (millimeters).

### Specifications

#### Performance

- Hydraulic Capacity: 129 GPM (488 LPM)
- Operating Speed: 3,200 rpm
- G-Force: 1,975 G
- Sigma Value: 11,916 ft<sup>2</sup> (1,107 m<sup>2</sup>)
- Solids Discharge: 27 GPM (6.1 m<sup>3</sup>/h)

#### Rotating Assembly

- Bowl Diameter: 13.9 in. (353.1 mm)
- Bowl Length: 33.9 in. (860.1 mm)
- Pond Depth: 2.3, 2.42, 2.54 in. (58.5, 61.5, 64.5 mm)
- Scroll Type: Single Lead Radial Flow
- Scroll Pitch: 4.31 in. (109.5 mm)
- Main Bearings: Grease Lubricated
- Internal Bearings: Grease Lubricated
- Feed Tube: Slotted - Position Variable

#### Rotating Assembly Material

- Bowl: Stainless Steel Duplex A890
- Scroll: Stainless Steel Duplex A890 AISI 304
- Scroll Flights: Stellite hard facing
- Discharge Bushings: Tungsten Carbide

#### Gearbox

- Type: Planetary
- Gear Ratio: 57:1
- Torque, maximum: 2,531 ft-lb (3,432 Nm)
- Differential Range: 10 to 79 rpm
- Weight: 159 lbs (72 Kg)

#### Nozzle Schedule

- Liquid Discharge: 6 in. Victaulic
- Solids Discharge: 21.0 x 13.8 in. (530 x 350 mm)
- Feed Tube: 2 in. NPT [Male Connection]

#### Fixed Drive Type

- Power: 400/460 V - 50/60 Hz, 3 Phase
- Main Drive Motor: 25 Hp (18.5 kW)
- Back Drive Motor: 10 Hp (7.5 kW)

#### Certification

- 414 Fixed Drive: ATEX CE Ex II 2G c IIB T3 or Class I, Division 1 hazardous areas for USA and Canada

### Dimensions and Weights

	X	Y	Z	Weight
414 Fixed Drive:	95.4 in. (2,424 mm)	48.8 in. (1,239 mm)	70.0 in. (1,778 mm)	4,850 lbs (2,200 Kg)

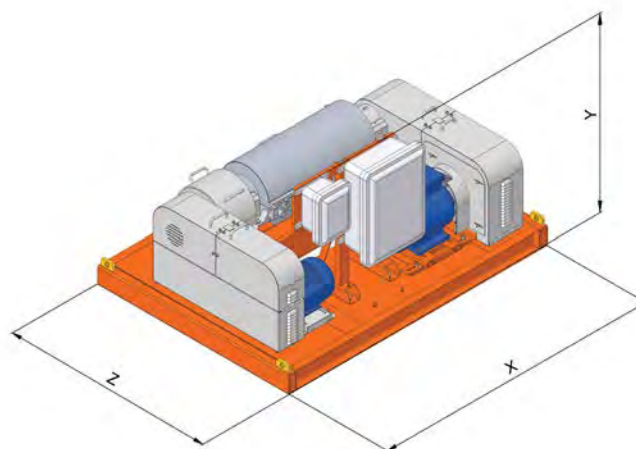

414 Fixed Drive

# Centrifuge Rotating Assemblies

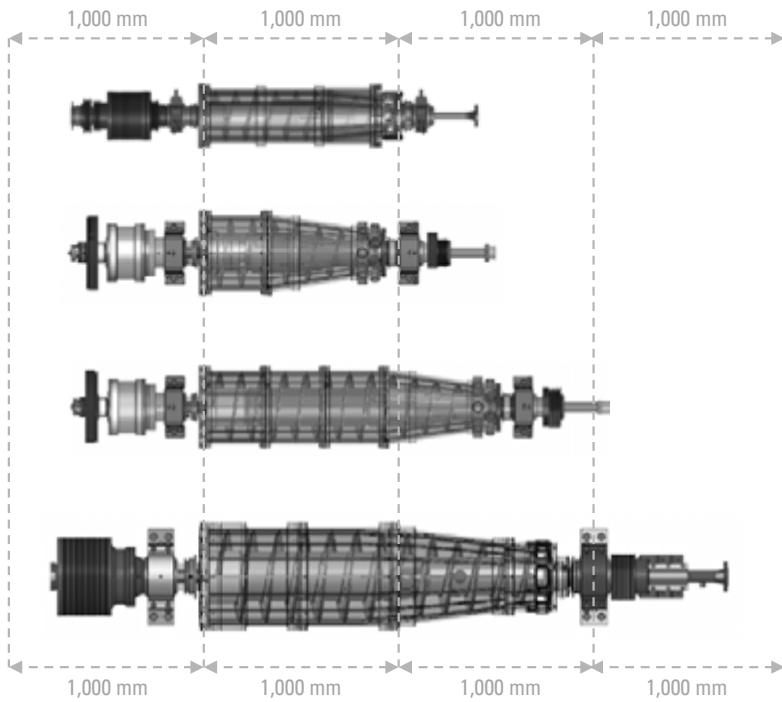

**Bowl Type: CD 250**

- Int. Diameter: 10.0 in. (253 mm)
- Int. Length: 37.1 in. (941.5 mm)
- Int. Volume (Mid Pond): 3.7 gal (14 l)

**Bowl Type: 414**

- Int. Diameter: 13.9 in. (353 mm)
- Int. Length: 33.9 in. (860 mm)
- Int. Volume (Mid Pond): 7.4 gal (28 l)

**Bowl Type: 518 HV**

- Int. Diameter: 13.9 in. (353 mm)
- Int. Length: 57.5 in. (1,461 mm)
- Int. Volume (Mid Pond): 16.1 gal (61 l)

**Bowl Type: CD 500 HV**

- Int. Diameter: 18.6 in. (472 mm)
- Int. Length: 67.5 in. (1,715 mm)
- Int. Volume (Mid Pond): 25.9 gal (98 l)

# Centrifuge Foot-Print Comparison

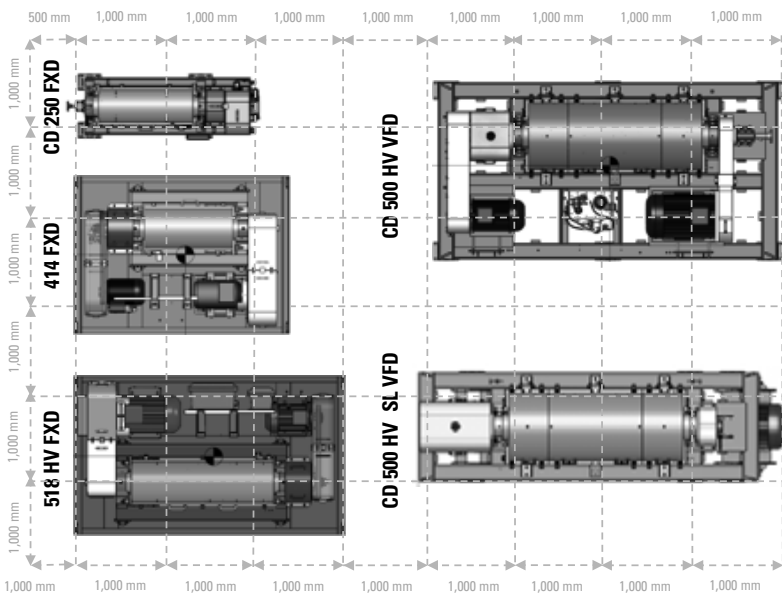

**Footprint: CD 250 Fixed Drive**

- Length: 81.8 in. (2,077 mm)
- Width: 31.5 in. (799 mm)

**Footprint: 414 Fixed Drive**

- Length: 95.4 in. (2,424 mm)
- Width: 70.0 in. (1,778 mm)

**Footprint: 518 HV Fixed Drive**

- Length: 119.0 in. (3,023 mm)
- Width: 70.0 in. (1,778 mm)

**Footprint: CD 500 HV VFD**

- Length: 155.4 in. (3,946 mm)
- Width: 79.5 in. (2,020 mm)

**Footprint: CD 500 HV SL VFD**

- Length: 163.3 in. (4,149 mm)
- Width: 48.4 in. (1,230 mm)

# DEWATERING



M-I SWACO has engineered portable and containerized DEWATERING technologies that remove colloidal-sized particles that can seriously degrade the performance of water-base drilling fluids. The DEWATERING systems eliminate the need for costly dilution to maintain density and rheological properties, thereby conserving water, reducing waste volumes and costs.

The fine particles are removed through a chemically enhanced process of enhanced centrifugation that is much more cost-effective than using a single high-speed centrifuge. A number of designs are available to fit within any onshore or offshore rig requirement. Regardless of the unit used, M-I SWACO DEWATERING<sup>+</sup> systems provide operators a powerful tool for maintaining optimum drilling fluid properties, while minimizing waste, reducing treatment and disposal costs.

## Features

- High-capacity centrifuge
- Fully-contained unit with a small footprint for rigs with limited space
- Optional magnetic flow meter records volumes processed as well as water usage
- Allows cut-point to be reduced below the capabilities of standard solids-control equipment operating parameters
- Water-recycling capability makes it easier to keep mud in good condition at all times and is ideal where water is scarce

## Benefits

- Recycling of the fluid phase reduces water-hauling, drilling fluid and disposal costs
- Optimizes environmental performance
- Reduces chemical costs
- Maintains active mud in good working condition



# OPTM-IZER



The OPTM-IZER<sup>†</sup> solids control system is a mobile closed-loop unit engineered to save time, labor and installation costs for onshore operations.

The OPTM-IZER unit can work alone or as a supplement to rig shakers. It can be moved in, rigged up and put into operation on location within two hours of arrival.

The OPTM-IZER unit was engineered specifically for land rigs not equipped to perform specialized solids-control operations and that do not require these capabilities while drilling the entire well. The OPTM-IZER unit is for land-based drilling operations that require barite recovery, high-capacity processing, dewatering and/or mud stripping.

## Features

- Three processing modes
- Fully variable speed centrifuge technology, from single centrifuges to dual big-bowl packages
- Automatic level control and automation package
- Available in 9 ft, 10 ft and 12 ft widths
- All-inclusive single-load, closed-loop package solution
- Optional cold-weather package

## Benefits

- Better solids removal to reduce dilution and waste volumes
- Lowers the percentage of liquid on cuttings
- Fully contained to avoid any liquid/solid spills
- Increased solids removal efficiency
- Lower mobilization, transportation and installation costs
- Reduced manpower requirements
- No crane picks
- Lower drilling-waste disposal costs

# CLEANCUT Cuttings Collection and Transportation System



The patented CLEAN CUT<sup>†</sup> system from M-I SWACO gives operators a flexible solution for improving the safety and efficiency of drill cuttings containment and disposal. The system captures the drill cuttings as they exit the shaker and keeps them contained in a sealed system all the way to final processing, using positive pressure pneumatic conveying.

## Flexible, reliable and powerful

Offshore operators face a growing requirement for zero or near-zero discharge of drill solids. As environmental regulations have tightened, operators have had to rethink the way in which cuttings contaminated with oil- and synthetic-base drilling fluids are handled. Several methods have been developed to handle these contaminated cuttings, including skip-and-ship for shore disposal, slurrification for disposal into formation, and thermal desorption both onshore and offshore.

The temporary bulk storage of drill cuttings provided by the CLEAN CUT system protects drilling logistics from interruption by weather, crane or logistics issues, allowing peak drill cuttings volumes to be held for later processing while drilling continues. This flexibility can prevent expensive downtime on critical drilling operations. The bulk transfer of drill cuttings from rig to supply boat, and from supply boat to final process location enables large volumes of drill cuttings to be handled safely offshore, eliminating the numerous, potentially risky crane lifts required by cuttings boxes.

The CLEAN CUT system is a field-proven technology with an outstanding record of reliability and performance worldwide. It has been used from the Arctic to the tropics, from deepwater to remote jungle locations, on drill ships, semi-submersible rigs, jack-ups, platforms, supply boats and barges.

## Features and Benefits

### Safety

- Conveying is fully enclosed, keeping personnel and drill cuttings separate
- Crane lifts are minimized, improving offshore safety
- Equipment is specified to hazardous-zone classifications

### Ease of Use

- Flexible installation to suit rig layout with small equipment footprints
- The system transfers untreated cuttings at high rates
- Adds flexibility and reliability to operations including shipping cuttings to shore, inter-field transfer, slurrification and disposal, and thermal treatment offshore and onshore

### Reliability

- Dense phase conveying technology, proven in oilfield service with drill cuttings since 2000
- Outstanding equipment uptime record of 99.8%
- Totally enclosed system to protect the environment
- No additions to waste stream which may harm downstream processes

# VACUUM COLLECTION SYSTEM (VCS)



The VACUUM COLLECTION SYSTEM<sup>†</sup> (VCS<sup>†</sup>) from M-I SWACO collects, moves and stores drilled cuttings within a totally enclosed environment that minimizes spills and contamination.

Rigs and/or other installations requiring an enclosed system for: cuttings collection and transportation; slurrification and re-injection; rig, pit and tank cleaning; vessel cleaning; and fluid recovery.

With growing concerns for personnel safety, environmental issues and an increased emphasis on saving costly rig time, the industry has required a totally enclosed system for collecting and storing drilled cuttings.

## Features and Benefits

### Field-Proven

- Operated successfully on several hundred wells for operators around the world since 1993

### Versatile

- Suitable for most applications: cuttings collection and transportation; waste injection; rig, pit and tank cleaning; vessel cleaning; and fluid recovery

### Safe

- No hazardous moving parts
- Fill sensors for automatic shut-off
- Vacuum power skid is completely contained
- Customized, non-sparking blower design with hazardous-duty class electric motors
- Explosion-proof (Class I, Zone I) 100 hp electric motor

### Efficient

- Maximizes filling of cuttings-collection modules
- Cuttings collection and continuous vacuum does not interrupt drilling

- Conveys fluids and cuttings horizontally and vertically, saving valuable rig-floor space
- Skid-mounted diaphragm pump for recycling and fluid transfer

### Environmental Compliance

- Designed to meet the most stringent discharge regulations

### Total Containment

- Contains all drilling waste streams
- Minimizes potential contamination during drilling

### Modular Design

- Flexible design allows central rig location with remote on/off
- Suitable for all rig configurations

### Simple Installation

- Minimal or no welding required
- Makes hookup faster and safer
- Preinstalled collection pipe serves multiple collection locations
- Equipment tool box with spare parts includes connections, pipe, wands and hoses



# Technical specifications for the VACUUM COLLECTION SYSTEM

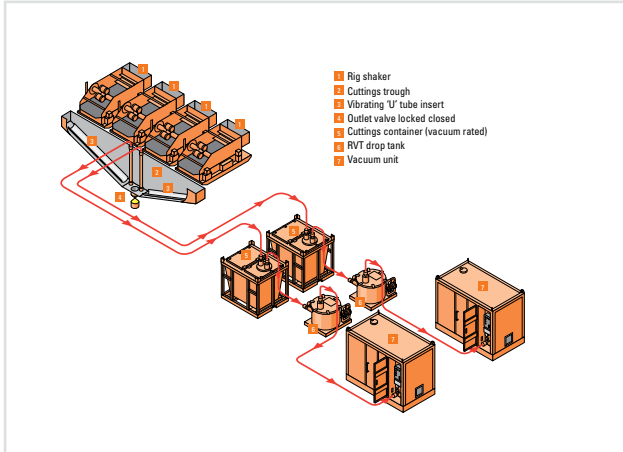

Vacuum Cuttings Collection

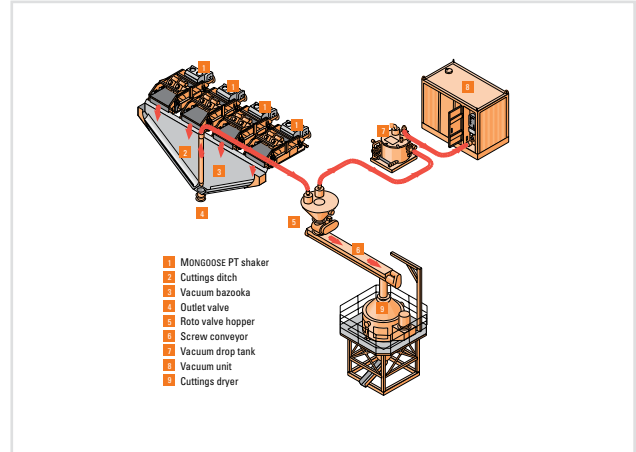

Cuttings collection to feed dryer

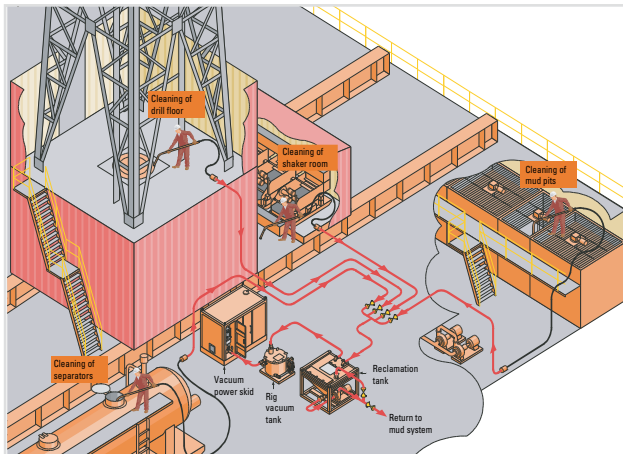

Rig- and tank-cleaning operations

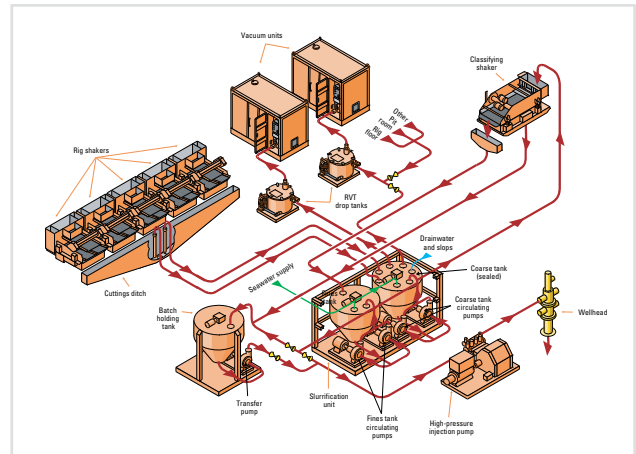

Slurrification and re-injection



The VCS modular components enable usage in a wide variety of rig operations including:

- Total cuttings containment
- Secondary recovery where total cuttings containment is not required
- Secondary mud-recovery systems
- Cuttings waste injection systems
- Tank and vessel cleaning
- Mud-spill cleanup on rig floor
- Pit cleaning for mud-systemchange out
- Liquid-waste-stream transfer
- Non-hazardous oilfield-waste minimization, recycling and cleanup



# Technical specifications for the VACUUM COLLECTION SYSTEM

## Vacuum Power Skid

The VACUUM COLLECTION SYSTEM is a powerful drill cuttings collection system designed specifically for the oil industry. Easy to install with little or no welding required, it minimizes costly rig time for preparation and installation. At the heart of the system is the VACUUM POWER SKID. Patented,<sup>1</sup> the "QUIET VAC™" Power Skid features a sound-insulated enclosure and an explosion-proof Class I, Zone II electric motor.

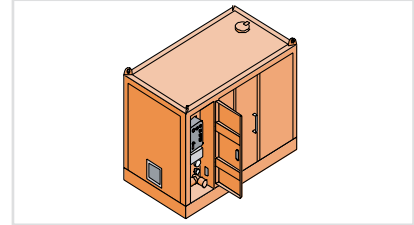

Vacuum unit specifications				
Model	Length in. (mm)	Width in. (mm)	Height in. (mm)	Weight lb (kg)
100 hp Unit	109 (2,762)	74.5 (1,892)	72 (1,828)	12,000 (5,443)
Motor: 480 volts, 3-phase 200 amp		Air Flow: 1,541 ft <sup>3</sup> /min (2,618.1 m <sup>3</sup> /hr)		

## Rig Vacuum Tank (RVT)

The RVT is an interceptor tank for liquids and solids which sits in front of the VACUUM POWER SKID. It has a level switch which will stop vacuuming operations when the tank need emptied, preventing carryover of material to the VPS. The RVT is used in conjunction with vacuum cuttings box filling to prevent any carryover of material from a full box.

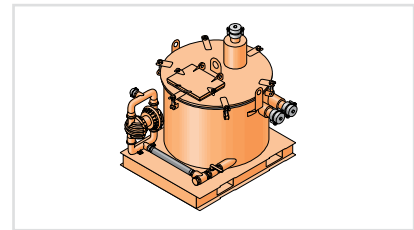

RVT tank specifications				
Model	Length in. (mm)	Width in. (mm)	Height in. (mm)	Weight lb (kg)
Rig Vacuum Tank (RVT)	60 (1,270)	53 (1,651)	60 (1,524)	2,000 (907)

## Continuous vacuum rotary hopper

Versatile vacuum-fed rotary hopper is an ideal solution for operations where vacuumed materials need to be discharged into separate non-vacuum-rated receptacles. The hopper allows continuous vacuum collection along with continuous discharge of materials into open-top waste injection units, standard open-top cuttings containers, or feeding of materials to cuttings dryers.



Rotary hopper specifications				
Model	Length in. (mm)	Width in. (mm)	Height in. (mm)	Weight lb (kg)
Rotary Hopper Specifications	56 (1,422)	59 (1,499)	72 (1,829)	3,200 (1,451)
Holding Tanks: (2) capacity 5 bbl each		Motor (2 hp): 480 volts, 3-phase 10 Amp		

<sup>1</sup>Protected by one or more of the following: U.S. Patent Nos. 5,402,857; 5,564,509; Des. 296,027; Des. 337,809; UK Patent No. GB 2 286 615. Other domestic and foreign patents pending.

# Cuttings Dryer (VERTI-G)



The VERTI-G<sup>+</sup> cuttings dryer features a state-of-the-art design that can process varying amounts of cuttings and fluids, typically up to 60 tons (61 metric tons) per hour. Dry solids discharged from the dryer are typically <5% oil content by wet weight.

## Size and capacity

The VERTI-G Cuttings Dryer delivers one of the best performing, most dependable dryers on the market.

The VERTI-G unit incorporates a high-speed vertical centrifuge that achieves maximum liquids/solids separation in large volume processing. This gives operators a critical advantage in meeting increasingly stringent environmental rules for offshore cuttings disposal.

The VERTI-G unit improves overall cost-efficiency. Valuable drilling fluids can be recovered from cuttings, as well as whole mud lost from shaker failure and rig motion. The VERTI-G unit is effective with oil- and synthetic-base drilling fluids and minimizes waste volume, dramatically reducing disposal costs.

The VERTI-G Cuttings Dryer is available in the following types:

- Compact VERTI-G (Bottom Discharge or Screw Conveyor Discharge)
- Standard VERTI-G

## Features and Benefits

### Superior environmental performance

- Highly effective liquids/solids separation minimizes fluid content of cuttings prior to offshore discharge
- Drilling-fluid testing and analysis available through M-I SWACO to monitor system effectiveness
- Improved fluid separation reduces waste disposal volumes in zero-discharge applications and significantly lowers organic loading levels on the sea floor

### Improved drilling-fluid recovery

- Effective separation reclaims high percentages of fluid from cuttings; also recovers whole mud lost from shaker failure, rig motion and screen blinding
- Valuable recovered fluids can be added back to the active mud system

### Safety

- Explosion-proof motors and control panels are certified for use in CE/ATEX (Zone 1) areas
- Integrated, custom-built stands and walkways reduce risk to personnel

### Operational Benefits

- Experienced M-I SWACO personnel maintain peak operating efficiency

- High-capacity, continuous-feed units have the throughput to keep up with drilling operations

- Programmable Logic Controller (PLC), with automatic warning indicators, monitors bearing temperatures, adsorbed current, torque and total operating hours. Ability to control auxiliary equipment from VERTI-G control panel (screw conveyor and flushing pump)

- Lifting hoist on stand allows unit maintenance without interfering with rig crane

- Hard-faced, replaceable, adjustable cone flights reduce wear and ensure optimal tolerance

- Horizontal screens allow higher wiping efficiency and less plugging

### Ease of maintenance

- Flushing system prevents solids build up in the recovery area and minimizes shutdowns for cleaning

- Normal wear parts are easily accessible from the top of the unit; belts are easily changed without removing gear assembly

- Interchangeable hard-faced rotor blades protect rotor and gearbox from excessive erosion, minimizing main component failure

**The VERTI-G process**

Cuttings from shale shakers are conveyed to the VERTI-G Cuttings Dryer through a variety of site-engineered conveyance systems that include:

- Gravity feed
- Pneumatic transfer
- Vacuum transfer
- Screw conveyors

The flow of cuttings into the VERTI-G is PLC-controlled and continuously fed to yield optimum liquids/solids separation. Once cuttings are introduced into the dryer's charge hopper, widely-spaced, adjustable flights continuously direct cuttings to the screen surface. Flights are hard-faced to reduce wear and ensure optimum tolerance. Flights within the VERTI-G dryer create a rolling action that promotes further separation and prevents screen plugging. Under high G-forces created by the large cone diameter, liquids/solids separation

occurs instantly as cuttings make contact with the finer-mesh, high-capacity dryer screen while producing cleaner return fluid and drier solids discharge.

Solids are discharged at the screen bottom and fall by gravity into the water-flushed cuttings trough and shunted overboard. Solids can also be collected for onshore disposal. Processed liquids pass through the screen and then exit through one of two effluent openings.

The fluid is collected and pumped to the M-I SWACO decanting

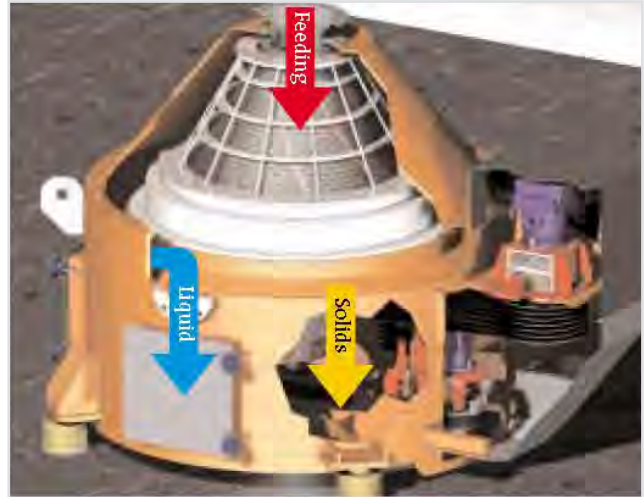

centrifuge for final processing and reuse in the active mud system.

**VERTI-G with Auger Feed**

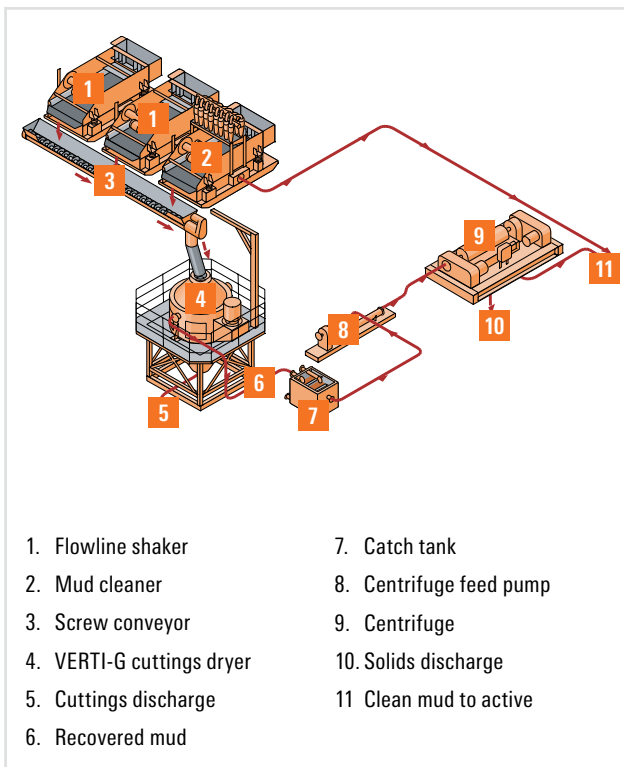

**VERTI-G with Roto Valve**

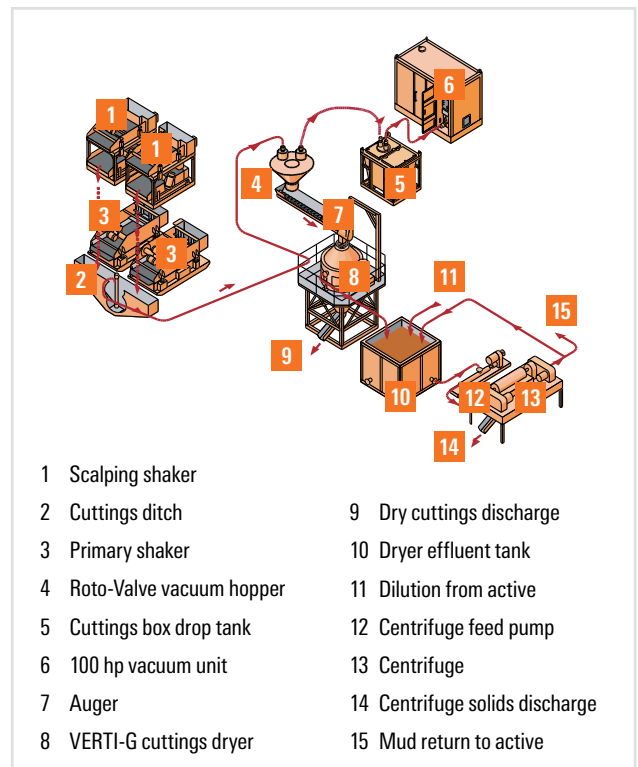

# Technical Specifications for the Compact VERTI-G Cuttings Dryer

## CVG (Bottom Discharge)

## CVG (Screw Conveyor Discharge)

All dimensions are expressed in inches (millimeters).

### Specifications

#### Performance

- Capacity: 60 Ton/Hr
- Operating Speed: 800 rpm
- G-Force: 327 G

#### Rotating Assembly

- Base Cone Diameter: 36.0 in. (914 mm)
- Cone Height: 21.9 in. (556 mm)
- Cone Angle: 60°
- Rotor Blades: Replaceable - Castolin D048 Hard-faced
- Flights Tolerance: Adjustable

#### Gearbox CVG

- Type: Planetary [Model; ZG 3700/13]
- Gear Ratio: 80:1
- Torque, maximum: 6,638 ft-lb (9,000 Nm)
- Differential Range: 10 rpm
- Weight: 474 lbs (215 Kg)

#### Screens Schedule

- Openings: 0.024 in. (0.6 mm)
- Openings: 0.016 in. (0.4 mm)
- Openings: 0.012 in. (0.3 mm)

#### Fixed Drive

- Power: 400/460 V - 50/60 Hz, 3 Phase
- Main Drive Motor: 75 Hp (55 kW)
- Screw Conveyor Motor\* (Qty 2 ): 5.4 Hp (4 kW)

\*Only on CVG (Screw Conveyor Discharge)

#### Certification

- CVG (Bottom Discharge): ATEX CE Ex II 2G c b IIB T3
- CVG (Screw Conveyor Discharge): ATEX CE Ex II 2G c b IIB T3
- IECEX Certification available from Q1/Q2 2014

### Dimensions and Weights

	X	Y	Z	Weight
CVG (Bottom Discharge)	104.1 in. (2,645 mm)	66.3 in. (1,684 mm)	78.7 in. (2,000 mm)	9,480 lbs (4,300 Kg)
CVG (Screw Conveyor Discharge)	117.1 in. (2,975 mm)	66.3 in. (1,684 mm)	78.7 in. (2,000 mm)	11,023 lbs (5,000 Kg)
VG Control Panel	88.6 in. (2,251 mm)	59.8 in. (1,520 mm)	29.5 in. (750 mm)	886 lbs (402 Kg)

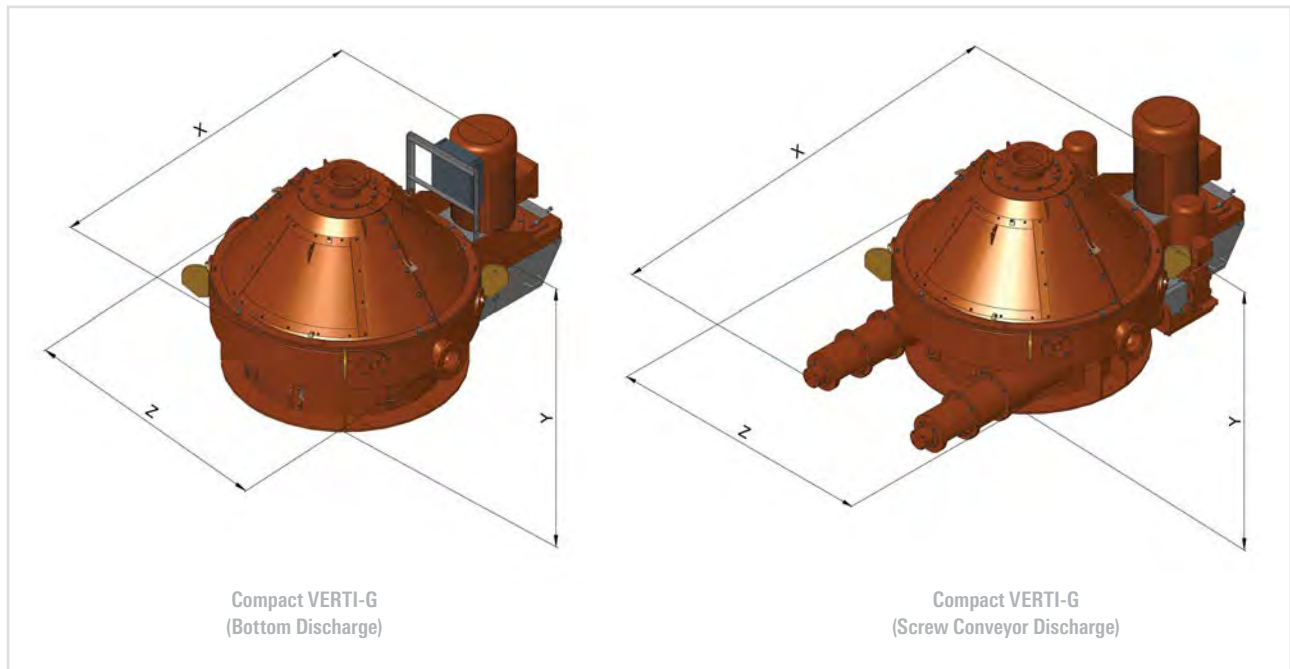



# Technical Specifications for the Standard VERTI-G Cuttings Dryer

## VGE-01

All dimensions are expressed in inches (millimeters).

### Specifications

#### Performance

- Capacity: 60 Ton/Hr
- Operating Speed: 800 rpm
- G-Force: 327 G

#### Rotating Assembly

- Base Cone Diameter: 36.0 in. (914 mm)
- Cone Height: 21.9 in. (556 mm)
- Cone Angle: 60°
- Rotor Blades: Replaceable - Castolin D048 Hard-faced
- Flights Tolerance: Adjustable

#### Gearbox VGE-01

- Type: Planetary [Model; ZG 4300/10]
- Gear Ratio: 80:1
- Torque, maximum: 8,113 ft-lb (11,000 Nm)
- Differential Range: 10 rpm
- Weight: 739 lbs (335 Kg)

#### Screens Schedule

- Openings: 0.024 in. (0.6 mm)
- Openings: 0.016 in. (0.4 mm)
- Openings: 0.012 in. (0.3 mm)

#### Fixed Drive

- Power: 400/460 V - 50/60 Hz, 3 Phase
- Main Drive Motor: 75 Hp (55 kW)

#### Certification

- VGE-01: ATEX CE Ex II 2G c b IIB T3

### Dimensions and Weights

	X	Y	Z	Weight
■ Standard VERTI-G (VGE-01)	109.3 in. (2,775 mm)	73.8 in. (1,874 mm)	85.6 in. (2,174 mm)	11,795 lbs (5,350 Kg)
■ VG Control Panel	88.6 in. (2,251 mm)	59.8 in. (1,520 mm)	29.5 in. (750 mm)	886 lbs (402 Kg)

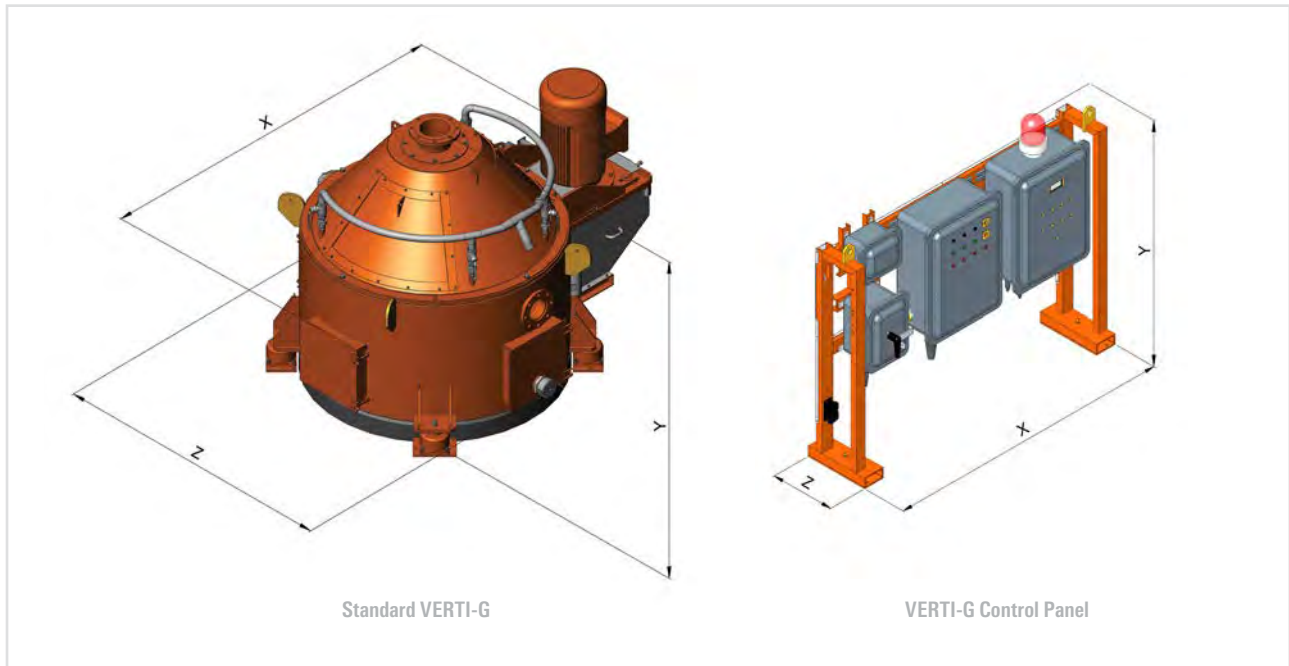

# THERMAL DESORPTION: HAMMERMILL Onshore

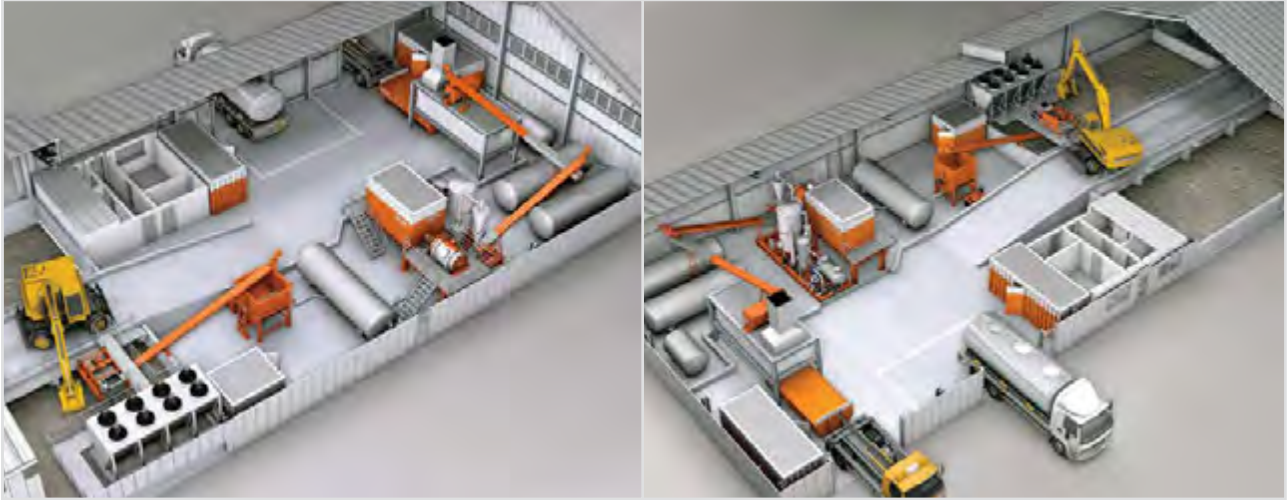

The HAMMERMILL desorption process is based on direct mechanical heating through the use of a pounding mill's action on the cuttings. The combination of high mechanical shear and in-situ heat generation creates an environment that promotes flash evaporation of water and hydrocarbons. There is no ignition source in this type of desorption process, hence the term "friction." This technology eliminates the need for large surfaces and complex systems for warming and maintaining a heat-transfer medium, e.g., hot oil, steam or exhaust gas. It is fast, clean and efficient to run.

Due to the operating flexibility of the mechanical approach to desorption, HAMMERMILL systems can be designed as compact units that meet the highest safety and explosion-proofing standards.

The drilling waste must be screened for larger objects by a simple shaker screen on top of the feed hopper. Double piston pumps have proven to be the most reliable method of introducing the material to the process mill. The efficient crushing of the solids results in significant amounts of ultra-fine particles following the vapors from the process chamber. These particles are efficiently removed by a cyclone and a special dust separator prior to the vapors moving through the condensers.

## Features

- ATEX approved
- CE marked
- Small footprint
- Low manpower requirements
- Operates very cleanly and quietly
- Ability to operate offshore

## Benefits

- Limited process temperature
- Very short retention time required for complete removal of oil in the solids
- Good condition of the recovered oil
- Efficient, intense agitation to break up solid particles, inducing efficient thermal desorption

# THERMAL DESORPTION: HAMMERMILL Offshore



The HAMMERMILL unit is specifically designed for offshore, capable of being installed in the space that would have been used for the skips previously used to collect and transport cuttings to shore.

Through the integration of the proven CLEAN CUT cuttings transfer and storage technology with an M-I SWACO Thermomechanical Cuttings Cleaner (TCC) modular design, we provide the total offshore solution, including:

- Pneumatic transfer of drilled cuttings offshore to a thermal system
  - Complete enclosed system
  - CLEAN CUT and HAMMERMILL PLC-controlled for reduced manpower requirements
  - Cross-trained CLEAN CUT and TCC engineers
  - Modular DNV 2-7.1 approved modules
  - Minimal rig-up/rig-down time
    - Plug and socket on cabling to reduce rig-up/rig-down time
- Best available technology for drive module featuring the new CAT C32 low emissions engine (less than Tier 2)
  - ATEX Approved
  - Hammermill technology utilizing friction to generate heat within the cuttings that separates the base oil without damaging its molecular structure
  - Offshore rigs and other installations where space is at a premium and where base oils must be recovered from drilled cuttings, both for the recovery of the base oil and for preparing the cuttings for disposal or reuse
  - Reduced manpower on the rig
  - Reduced crane lifts for lifting cuttings containers (skips) - reduced manpower - removal of additional deck hands on the rig to handle the skips
  - Reduced emissions

## Features

- ATEX approved
- CE marked
- Small footprint
- Low manpower requirements
- Operates very cleanly and quietly
- Ability to operate offshore

## Benefits

- Limited process temperature
- Very short retention time required for complete removal of oil in the solids
- Good condition of the recovered oil
- Efficient, intense agitation to break up solid particles, inducing efficient thermal desorption

# THERMAL PHASE SEPARATION (TPS)

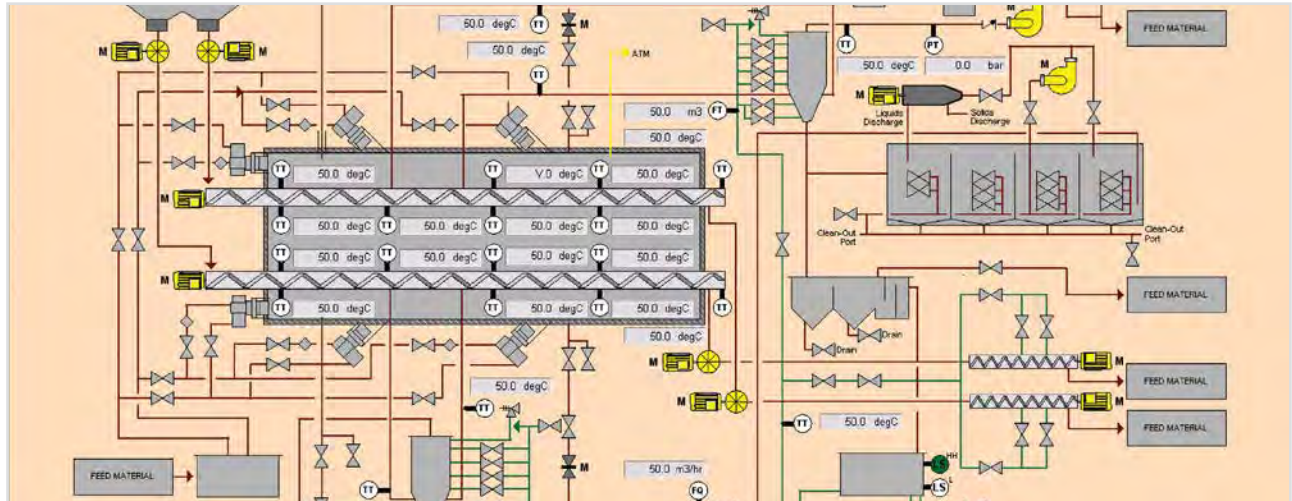

M-I SWACO THERMAL PHASE SEPARATION (TPS) technology delivers an unprecedented level of economy and environmental benefits in the treatment of drilling fluids and drilled cuttings. These systems provide a completely self-contained, versatile process based on indirectly heated thermal desorption.

Results of TPS technology include:

- Highly efficient hydrocarbon removal and recovery
- Unsurpassed recovered oil quality for onsite base oil recycling
- Low emissions that comply with all current guidelines

Our systems, based on three primary components - desorption chamber(s), gas/liquid treatment unit, and control unit - minimize treatment costs and achieve comprehensive environmental compliance.

## Features

- Processing rates in excess of 300 MT/day
- Future CE marked
- Modular design enables custom system configurations

## Benefits

- Operates with low emissions
- Recovers up to 85% of valuable base oil for immediate reuse
- Consistent treated solids results: <1% TPH and 10 ppm leachable TPH
- Significantly less solids carryover (<1% BS&W) in recovered oil
- Effectively treats high-liquid-content cuttings (>40% by weight)
- Superior recovered oil quality
- Minimal personnel requirements



# Cuttings Re-Injection (CRI)

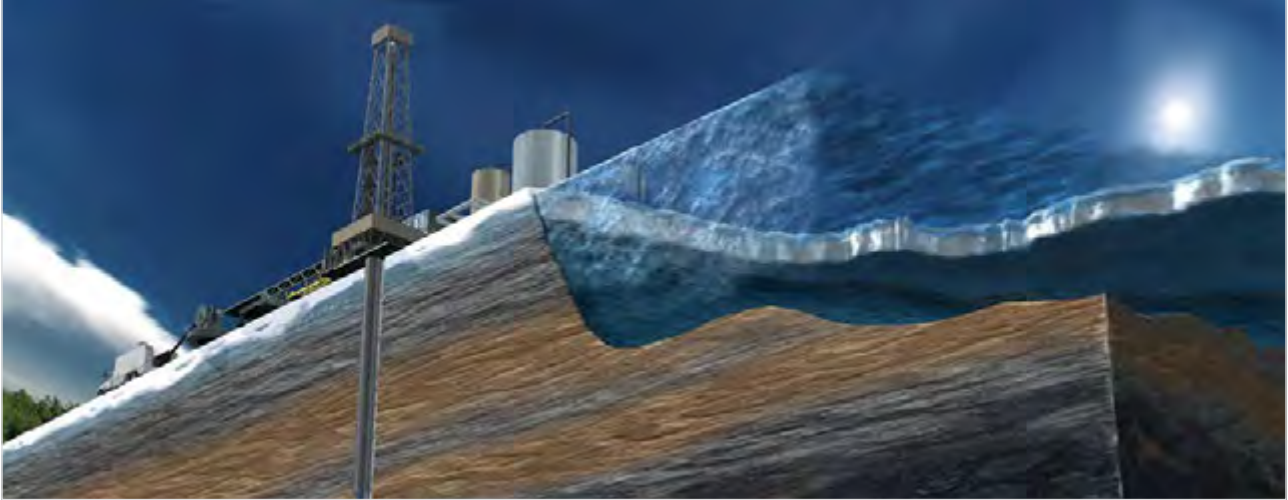

M-I SWACO has developed an integrated Cuttings Re-Injection (CRI) process that has emerged as a cost-effective and sound solution for drilled waste disposal at environmentally sensitive and remote asset developments.

CRI operations may be done in situ at or near the waste generation site eliminating the need to package and haul cuttings long distances to treatment facilities. Operators save time, labor, rig space and mitigate HSE risk by avoiding transportation over water or on roadways. Originally conceived solely for drill cuttings injection, the Cuttings Re-Injection process has expanded to include many other waste streams generated during E&P operations.

The Cuttings Re-Injection system includes a slurrification process whereby drilling waste is collected, mixed with water, and conditioned to form a stable slurry ready for injection into a suitable down-hole storage formation.

## Features

- All-inclusive process that includes geomechanical modeling and simulation, well and operation design, data acquisition, and monitoring assurance
- Multi-disciplinary network of engineers
- Highly trained operational personnel
- Specially dedicated injection training centers
- Capable of injecting variety of wastes, including slurrified cuttings, lube oil, rig drain fluids, produced water, waste mud and crude-oil contaminated cuttings, among others
- Includes collection and conveyance mechanism, high-pressure pump and slurrification systems, subsurface disposal domain and data collection and monitoring

## Benefits

- Provides permanent disposal solution
- Reduces disposal costs
- Minimizes environmental liabilities; meets all zero discharge requirements and lowers CO<sub>2</sub> emissions
- Customized solution

# System components

## Basic Components of Cuttings Re-Injection

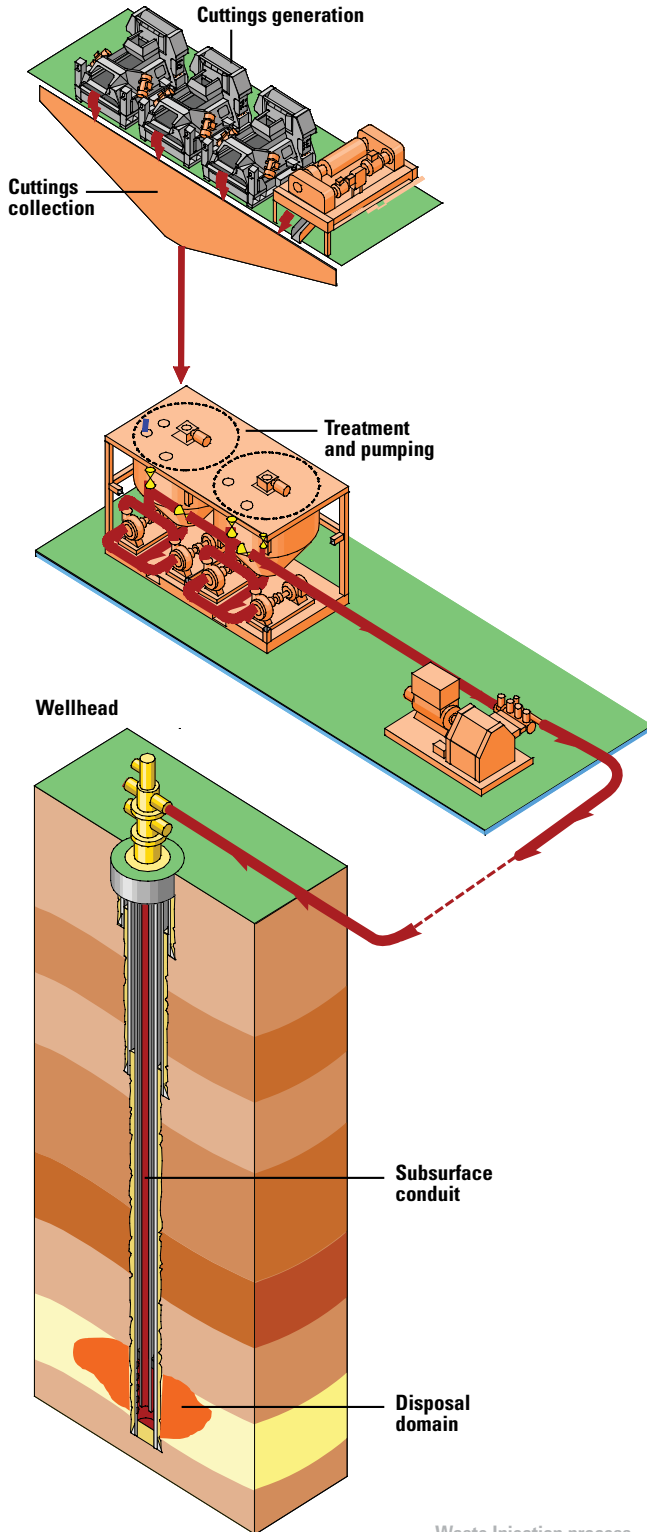

## Injection Process Overview

The Cuttings Re-Injection process involves the gathering of solids and wastes through a series of specialized equipment that classify, degrade, mix and condition them into stable and pumpable slurries. Afterwards, the slurry is injected via hydraulic fracturing into a subsurface formation that earlier had been analyzed and deemed suitable for the permanent isolation of the waste. The proper injection formation is identified at the onset as one that will ensure injected waste does not propagate into undesirable zones protecting the environment surrounding the disposal zone.

The equipment package comprises a conveyance apparatus, slurrification unit, high-pressure injection pumps and monitoring equipment. The skid-mounted Cuttings Re-Injection Analyst delivers real-time and recordable injection pressure, density and volume data. All of the equipment and processes are operated by high skilled specialists, who undergo extensive training at dedicated Cuttings Re-Injection training centers worldwide.

# DRILLING FLUID TEMPERATURE CONTROL SYSTEM (Mud Cooler)



The DRILLING FLUID TEMPERATURE CONTROL SYSTEM<sup>†</sup> was engineered specifically to reduce the risks and complications associated with drilling HTHP wells using oil-base drilling fluids.

The technology is specifically focused on efficient heat transfer in drilling fluids and has a proven track record, showing an impressive impact on drilling efficiency. This technology can reduce risk factors and drilling complications while simultaneously increasing safety and decreasing operating costs.

Even the most temperature-tolerant fluids have their limits before they begin to break down or behave erratically and cause problems such as fluid loss, reduced viscosity, stuck pipe and unstable filter cakes. In the case of oil- or synthetic-base fluids, additional problems can occur at the surface. The overheated fluids can release fumes that result in uncomfortable or hazardous breathing conditions for rig crews. In addition, any drilling fluids heated beyond their limits can produce inaccurate readings from Measurement While Drilling (MWD) and Logging While Drilling (LWD) tools as well as excessive wear on the elastomers found in these tools and in the BOP, riser, shakers, centrifuges and mud pumps.

## Features

- Skid-mounted, ready for immediate operation
- Effectively reduces drilling fluid temperature
- Engineered to ensure maximum serviceability
- Incorporates titanium plate heat exchangers
- Maintains oil-base fluids below their flash points
- Increases endurance and accuracy of downhole devices such as MWD and LWD
- Fewer additives required to maintain drilling-fluid rheological properties

## Benefits

- Better drilling-fluid performance
- Longer elastomer life in MWD/LWD tools, BOP, riser, shakers, centrifuges and pumps
- Reduces NPT on downhole tools
- Fewer conditioning additives required, lower drilling fluid costs
- Improves personnel safety and working environment
- MWD and logging tools can be used at greater depths
- Increased up-time strengthens your bottom line

# AUTOMATIC TANK CLEANING (ATC)



M-I SWACO has improved upon the slow, labor-intensive, dirty and potentially dangerous tank cleaning task with the AUTOMATIC TANK CLEANING<sup>†</sup> System that is completely automatic, designed to reduce cleaning time, reduce waste and reduce or eliminate entry into confined spaces. We have developed cleaning processes for both land and onshore drilling installations and on offshore supply boats, which greatly reduce, and in some cases eliminate, the need for pit and tank entry.

Whether onshore or offshore, tanks used for oil and gas exploration need to be cleaned, either to remove solids or to avoid cross contamination of fluids. Until now, tank cleaning has typically involved numerous laborers equipped with hoses, pressure washers, shovels and squeegees.

According to industry data, tank and pit cleaning operations required 9 million man hours annually to be spent in Confined Space Entry and generated 15.66 million barrels of waste. Having people working inside a tank is not only time consuming, but poses unnecessary health and safety risks.

Our patented system cleans the pit without prevacuuming of the settled solids. It incorporates a full recycling system which separates out the solids "on the fly," allowing the same small volume of wash water to be reused tank after tank. It eliminates or vastly reduces confined-space entry and can cut cleaning times by up to 80%.

## Features and Benefits

- Fully automated tank cleaning procedures
- Multiple Tank Cleaning Machines (TCMs) operate simultaneously
- Optimally positioned TCMs
- ATEX Certified
- Compact and portable to dockside and offshore (DNV 2.7-1 certified)
- Customized cleaning chemistry
- Wash-water recycling
- Saves up to 80% cleaning time compared to manual cleaning systems
- More thorough cleaning over entire tank
- Reduces risk as a result of confined-space entry
- Decreases generated waste by as much as 95%
- Easy to operate with a small crew
- Minimizes solids-haulage costs
- Reduces slop by recycling only 7m<sup>3</sup> (44 bbls) of wash water during cleaning process



# AUTOMATIC TANK CLEANING LITE (ATC LITE)



M-I SWACO builds on its field-proven AUTOMATIC TANK CLEANING LITE<sup>®</sup> (ATC) technology to provide the industry with a permanently installed mud tank cleaning system for offshore installations. The ATC LITE, which can also be truck mounted for land based operations, delivers the same waste reduction efficiencies by using only 6.5m<sup>3</sup> (41bbls) of wash water to clean multiple tanks. The obvious QHSE benefit is that man entry into tanks is minimized or eliminated.

ATC LITE is uniquely engineered for a range of mud tank cleaning and recycling applications, including long-term or permanent installation aboard offshore rigs and supply vessels. The ATC LITE is the only technology of its kind adaptable as a trailer-mounted rental unit for cleaning oil and water-base mud tanks on onshore drilling rigs. In addition, ATC LITE is designed to enable fixed installation at liquid mud plants.

## Features

- Fully automatic tank cleaning technology
- Continuous, closed-loop cleaning, recycling process
- Requires only 41 bbl (6.5 m<sup>3</sup>) of water on average
- Operates multiple TCM simultaneously
- Enhanced solids separation, water cleaning technologies
- Applicable for oil and water-based fluids
- Employs proprietary cleaning chemicals when cleaning OBM/SBM tanks
- Compact and mobile configuration
- Suitable for permanent installation
- Simplified operation
- Optional ATEX Zone 1, Class 1 Div 1 and non-hazardous area designations

## Benefits

- Eliminates or significantly reduces need for confined space entry
- Minimizes waste volume by up to 95%
- Promotes recycling
- Decreases environmental footprint
- Greatly reduces cleaning time compared with traditional tank cleaning
- Facilitates barite recovery
- Reduces overall waste management costs
- Enhances QHSE profile
- Reduces comparative labor requirements
- Lowers non-productive time
- Improves overall project economics

# MULTI-PHASE CLARIFIER (MPC)



The M-I SWACO MULTI PHASE CLARIFIER<sup>+</sup> (MPC) is an effective, automated, economical tool for first-stage separation of all hazardous drains systems on drilling rigs.

## Separation Capability

The MPC has the ability to break the drain runoff from multiple areas such as the rig floor and the shaker deck, into three waste streams:

- Water
- Free-oils (base, leaks, and accidents)
- Dense phase (whole mud and emulsions)

This waste stream separation is created without chemical or mechanical assistance. The MPC unit is designed to handle everyday offshore rig flows up to 150 gal/min and enable automated separation, collection, routing and processing of varying degrees of emulsified mixtures. The unit is capable of dropping out solids and heavy fluids/muds, separating water from free-oil, sending each waste stream to a desired location, and minimizing volumes for post-treatment.

## Offshore Rig Ready

With the MPC's small footprint, more than one water-solids-oil separator can be used on each rig. MPC technology can be used as a pre-qualifier for more elaborate water cleanup. Because solids can create problems with these more technically advanced downstream processes, the ability to drop solids out of multiple waste streams prior, reduces treatment volumes and cost.

The unit can be used to process all hazardous drains including:

- Shaker house
- Rig floor
- Main deck
- Cuttings collection area

## Innovative Design

The MPC unit is designed to break the flow from the various drains systems into three phases for additional processing, routing and/or storage. The collection drains targeted are primarily the shaker house and the rig floor. The main deck, helicopter pad and even the pump room can be considered for collection of waste fluids.

## Features and Benefits

- Can accommodate whole mud influx
- Small footprint
- No moving parts
- Automated
- Manual bypass option
- Low cost
- Separation technology for oil-based mud, fresh- and saltwater, and emulsions
- Most advanced initial multiphase separation technology
- Effective first-stage, no pressure separation/diversion of all phases
- Controlled closed loop management
- Reduced treatment volume
- Simple, rapid follow-up solids cleanout

# ENVIROUNIT



M-I SWACO can now deliver to the rig the mechanical and chemical processes used in its ENVIROCENTER<sup>+</sup> facilities through its ENVIROUNIT<sup>+</sup> module, a portable ENVIROCENTER facility for offshore applications where the chemical and mechanical processes are identical to the onshore facility.

The ENVIROCENTER concept employed in the ENVIROUNIT module became a success when new processes and chemicals made reclamation of water- or brine-contaminated oil-base drilling fluids possible, similar to completion-fluids reclamation.

The drilling-fluid-treatment process has a remarkable average of 90% reduction of the total waste volume and an average recovery of 36% of the total volume as high-quality drilling fluid. The 90% recovered includes reclaimed water, brine, drilling fluid and base oil that otherwise would be sent off for disposal. Depending on fluid type and value, level of contamination, cost of disposal and environmental regulations, the recovered drilling and completion fluids can be used anywhere in the world.

## Features and Benefits

- The ENVIROUNIT module helps operators reach their overall goal of waste minimization, fluid reuse, increased profit and improved margins
- ENVIROUNIT modules utilize the proven, successful approach and methods employed at M-I SWACO ENVIROCENTER facilities
- The drilling-fluid-treatment process has a remarkable average of 90% reduction of the total waste volume and an average recovery of 36% of the total volume as high-quality drilling fluid
- The ENVIROUNIT reclamation process offers operators significant improvements in drilling fluid costs and environmental expenditures
- The use of ENVIROUNIT filtration and remediation services offshore can deliver significant performance and cost benefits while simultaneously meeting environmental regulations
- New processes and chemicals have made reclamation of water- or brine-contaminated oil-base drilling fluids possible, similar to completion-fluids reclamation



# PRESSURE AND FLUID MANAGEMENT SYSTEM (PFMS)



M-I SWACO has engineered its compact PRESSURE AND FLUID MANAGEMENT SYSTEM<sup>†</sup> specifically for the unique demands of CT applications requiring precision in pressure and solids control while having a small equipment footprint.

Typical pressure and solids control equipment layouts have frequently been unwieldy, making them ill-suited for space-challenged locations and presenting logistical and economic challenges. In addition, operators and drilling contractors have often found themselves at an operational disadvantage when trying to headoff well control, stuck pipe, reservoir damage and other downhole and environmental issues that can render a project uneconomic.

## Features

- Compact skid-mounted modular system
- Continuous closed-loop operation
- Advanced pressure and solids control technologies
- 154-bbl, three-compartment tank holding pumping, mixing and fluid-moving components
- No welding or bolting required
- Self-contained electrical and plumbing systems
- Capabilities to remove silt and sand particles from 5 to 25 microns
- Meets applicable transportation height and weight regulations
- Sensitive components for controlling wellhead, casing, and drill-pipe pressures
- Chokes rated for severe service conditions
- Advanced gas separation technologies

## Benefits

- Small footprint
- Precise pressure monitoring and control
- Generates drier cuttings
- Fast rig-up and rig-down
- Extended screen life
- Reduced requirement for additional hoses, pumps and lines
- Reduced waste disposal and fluid costs
- Optimized environmental compliance
- Reduced logistical challenges
- Hazardous gas removed from drilling and completion fluids
- Reduced formation damage
- Enhanced rig safety
- High durability and reliability



# CARBONTRACKER

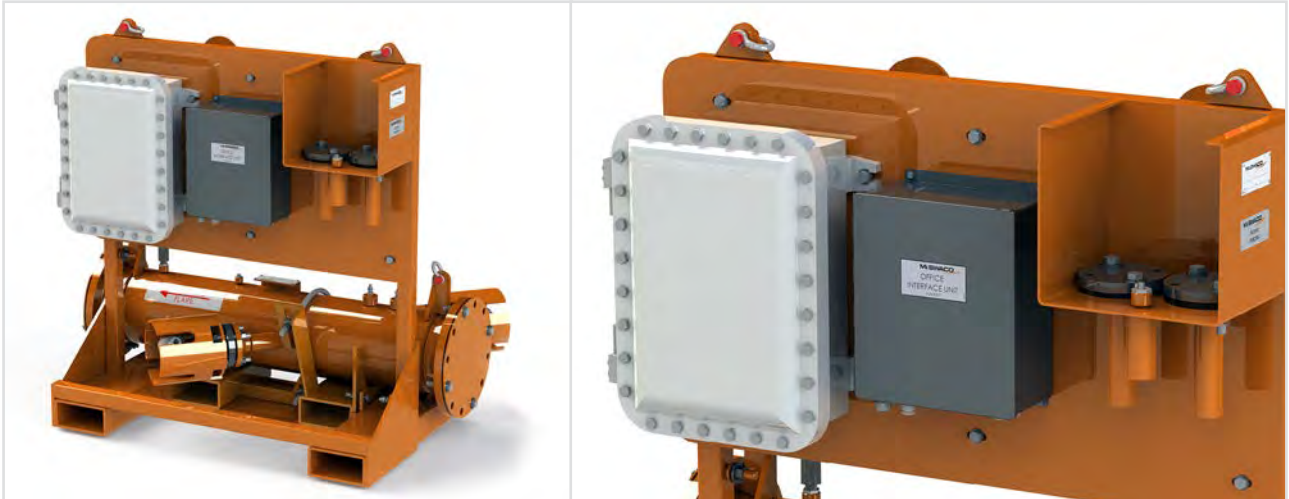

The CARBONTRACKER<sup>†</sup> gas flow measurement system was engineered to measure the volume of gas produced while drilling. The CARBONTRACKER gas meter represents a step-change innovation in helping operators minimize the environment impact of their operations, including the carbon footprint.

The CARBONTRACKER gas meter is suitable offshore or onshore and is particularly beneficial in tight-gas shale plays. The CARBONTRACKER gas meter installs directly into the flare line to provide real-time accurate gas flow measurement and composition. The CARBONTRACKER gas meter is applicable for any situation requiring a determination of the amount of gas being flared while drilling. It is particularly beneficial for reservoir characterization by detecting and monitoring gas flow during tight-gas, underbalanced-drilling (UBD).

## Features

- Measures hydrocarbon-gas velocity from 0.1 to 275 ft/sec (0.03 to 83.8 m/sec)
- Ultrasonic flow measurement technology
- Integrated data acquisition and storage
- No moving parts; tolerates dirty or wet conditions
- Works in the presence of CO<sub>2</sub>
- No onsite technician required for operation
- Measures velocity, volumetric flow and mass flow
- Built-in power supply for pressure and temperature transmitters
- Digital interface: Wellsite Information Transfer Specification (WITS) Level 0
- No obstruction of the flare line

## Benefits

- Adds another degree of certainty to tight-gas exploration and development
- Potential to increase efficiency of well delivery through accurate data and more informed decisions
- Reliable in noisy and/or highly contaminated environments
- Self-operating with no drain on personnel time
- Accurate flow rates independent of gas composition
- Minimal maintenance
- Readily communicates with rig instrumentation
- Self-diagnostics maintain accuracy

# CD-1400 CENTRIFUGAL D-GASSER



The M-I SWACO CD-1400 CENTRIFUGAL MUD D-GASSER† unit provides an innovative and space-saving solution to degassing problems. The D-GASSER units use a patented, centrifugal-force system rather than conventional vacuum or impact systems.

M-I SWACO CD-1400 units exert centrifugal force to the mud, multiplying the force acting on the gas bubbles to increase buoyancy and release. The increase in buoyancy accelerates the bubble-rise velocity. As the bubbles rise toward the surface, they escape the mud and are further broken down by flow turbulence.

The freed gas and the gas-free mud are then separately discharged as desired.

## Features and Benefits

### Removes entrained gases

- The CENTRIFUGAL D-GASSER units remove all of the entrained gases from the drilling fluids in the return flow by using high-speed centrifugal force

### Reduces potential blowouts

- The removal of entrained gases, including H<sub>2</sub>S and corrosive oxygen, from drilling fluids reduces the threat of dangerous and costly blowouts caused by recirculating gas-cut mud

### In-tank mounting

- Easy-to-install, in-tank mounting virtually eliminates the need for rig-floor space

### Self-contained

- The unit is complete with centrifugal cylinder unit, screens, electric motor and mount

### High performance

- Provides lowest hp/GPM throughput ratio, generating up to 1,000 to 1,300 GPM (4,164 to 4,921 L/min), depending on operating conditions

# COMPACT VACUUM D-GASSER



The M-I SWACO COMPACT VACUUM D-GASSER<sup>†</sup> unit works by removing entrained gases from the drilling fluid. Vacuum degassing is more effective than atmospheric degassing due to the exposure of the drilling fluid to pressures well below ambient atmospheric pressure.

The unit directs the incoming fluid flow over internal conical disks that create large surface areas over which thin layers of the fluid continuously flow. The transit time required for the gas to travel up, through the fluid and “break out” of the mud is minimized by spreading the fluid into thin layers.

At pressures below atmospheric pressure, the rate at which gas separates from a fluid is accelerated. The low pressure promotes the growth of large gas bubbles which rise rapidly to the nearest surface.

The free gas that breaks out of the drilling fluid is continuously removed from the vessel by the action of the piston-style vacuum pump on the unit. The removed gas is typically directed to the flare stack.

The level of mud within the vessel is controlled by a float valve to ensure that the disk stack is never submerged. As fluid level rises and lifts the float, air enters the vessel through the three-way valve to decrease the vacuum inside the vessel. With less vacuum inside the vessel, the rate at which fluid is drawn into the tank slows and the rate at which fluid exits the vessel increases. The fluid level inside the vessel drops rapidly until the float lowers and full vacuum is restored.

A liquid-trap tank in the gas-removal piping collects any fluid or condensate that may have entered the gas-removal piping. A float ball in the liquid-trap tank prevents the liquids from entering the vacuum pump.

## Features and Benefits

- Corrosion-proof internal conical disks reduce repair and maintenance costs
- Large Cleanout Port allows easier access for cleaning inside of D-GASSER
- Large surface area allows gas entrained in mud to be released effectively
- Interchangeability of many of the parts with the Horizontal Vacuum D-GASSER allows use of existing inventory parts
- Same field-proven vacuum pump as Horizontal Vacuum D-GASSER
- Short footprint can be installed in smaller spaces

# HORIZONTAL VACUUM D-GASSER

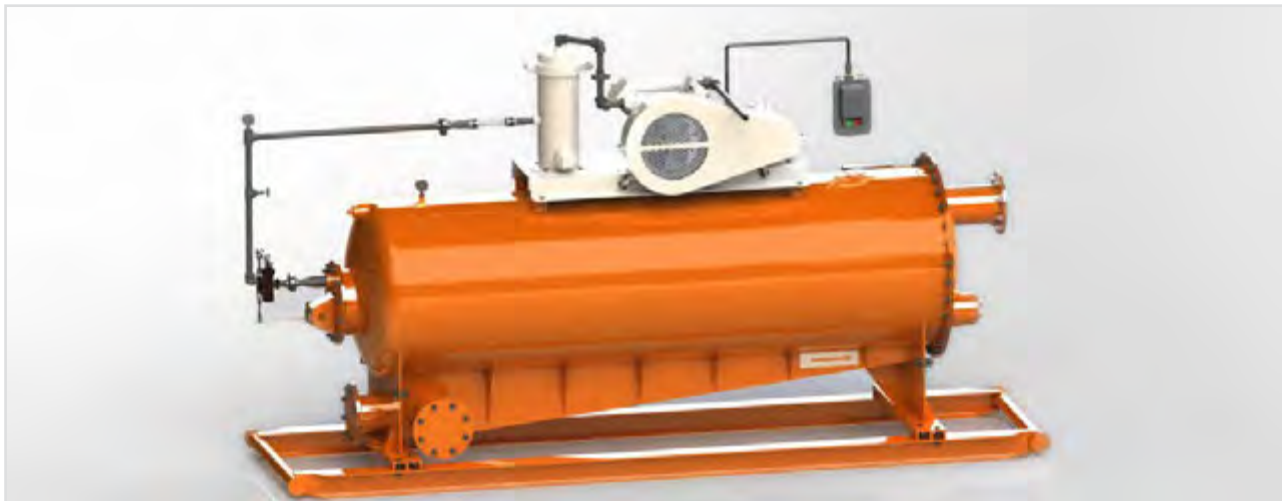

Introduced in 1951, the M-I SWACO Horizontal Vacuum D-GASSER<sup>†</sup> has performed reliably on over 200,000 wells and earned its reputation as the standard of the industry.

All M-I SWACO D-GASSER units are designed to remove virtually all entrained gases, including H<sub>2</sub>S and corrosive oxygen, from drilling mud. This reduces the threat of dangerous and costly blowouts caused by recirculating gas-cut mud.

The return-flow, gas-cut mud is drawn into the tank through a vacuum created by the discharge jet and pump. The mud is then dispersed in a thin layer over a two-tier, baffle-plate system where the entrained gas, including H<sub>2</sub>S and corrosive oxygen, is recovered by the vacuum pump. The freed gas is then discharged at a safe distance from the drilling operation while the restored mud is returned to the active mud system.

## Features

- Skid-mounted design simplifies spotting and installation
- Totally self-contained
- Three-way float valve allows venting to the flare line during H<sub>2</sub>S service
- Only three moving parts
- Rugged construction
- Corrosion-resistant, epoxy coated inside and out to ensure long life and minimum maintenance

## Benefits

- Removes virtually all entrained gases, including H<sub>2</sub>S and corrosive oxygen, from drilling fluids
- Reduces the threat of dangerous and costly blowouts
- Handles up to 1,000 GPM (3,785.4 L/min)
- Restores mud to its original density allowing for reuse in the active mud system



# MUD/GAS SEPARATOR



The M-I SWACO MUD/GAS SEPARATOR is ideal to assist in controlling dangerous, near-surface expansion and accumulation of gas during a well kick.

The gas delivery from the MUD/GAS SEPARATOR to the flare line can be controlled by a back-pressure manifold (valve) in the flare line.

The M-I SWACO MUD/GAS SEPARATOR consists of a cylindrical pressure vessel in a fixed vertical position. Inside is a series of specially angled baffle plates, stepped from the top to the bottom.

When contaminated mud is routed into the separator, it flows downward successively over each plate. During this process, the heads of entrained gases “break out.” The released gas is then carried by the vent lines to a remote location where it can be safely flared.

The flow of liquid from the vessel can be regulated by a liquid-level-control valve or a U-tube, ensuring adequate retention time in the separator for the gas to break out.

## Features and Benefits

- Separates large volumes of free gas including H<sub>2</sub>S
- Reduces threat of hazardous and toxic gases
- Skid-mounted for easy transport
- Versatile configurations
- Designed to ASME and NACE specifications
- Corrosion-resistant epoxy coated to ensure long life

# SUPER MUD/GAS SEPARATOR (SMGS)



The M-I SWACO SUPER MUD/GAS SEPARATOR<sup>†</sup> offers the highest gas- and liquid-handling capacity available. Its highly efficient baffling system maximizes mud/gas separation, enabling operators to drill deeper, larger-diameter wells and exploratory wells at higher circulating rates while safely handling greater volumes of gas. It also minimizes mist carryover and gas-cut mud at the flowline.

## Features and Benefits

**Large 6 x 22.3 ft (1.8 x 6.8 m) diameter vessel with 12 in. (304.8 mm) flare line**

- Allows the highest gas- and liquid-handling capacity available

## Optimizes safety and control

- The SUPER MUD/GAS SEPARATOR unit enhances safe drilling practices during underbalanced conditions, improves “kick” handling capabilities, permits optimum circulation rates and large-diameter holes to be drilled through the targeted zone, provides more efficient separation of gas-cut mud in either gas or oil environments

## High-efficiency baffle system

- Maximizes mud/gas separation, minimizes mist carryover which produces a cleaner flare and minimizes gas-cut mud at the flowline

## Capable of pressured operation.

- Increases gas- and liquid-handling capacities and permits immediate sale of gas during drilling operations

**Adjustable U-tube (liquid seal) height to 14 ft (4.3 m) without additional elevation of the vessel**

- Increases vessel pressure, creating higher flare capacity, enabling more efficient separation of emulsions and gas-cut mud in either gas or oil environments

**Higher liquid-capacity vessel with multiple nozzle ports.**

- Permits pumping of “hot” mud directly into the vessel to reduce gas hydrates. Increases mud gradient within U-tube to increase gas-handling capacity

**Manufactured to exacting standards in accordance with:**

- NACE MR-01-75 for H<sub>2</sub>S service. Provides for safe handling of corrosive, deadly sour gas and gas-cut drilling fluids
- OSHA 29CFR 1910 for safety. Provides safe and easy access for rig-up and servicing via ladder and platform system
- ASME boiler and pressure vessel code Section VIII, Division I, Section IX, lethal service and so stamped. Provides maximum rigsite safety during underbalanced drilling operations

# AUTOCHOKE



The M-I SWACO AUTOCHOKE<sup>®</sup> unit provides automatic, precise pressure control. It is the best choke technology available today for UBD and MPD applications.

The AUTOCHOKE unit regulates casing pressure automatically under all conditions for a wide range of tasks: regulating mud pump start-up or shutdown, making and breaking drill-pipe connections, or allowing mud/gas flows alternately through the choke.

Stripping pipe is simpler and safer with the AUTOCHOKE unit due to its ability to maintain casing pressure. As drill pipe is lowered into the hole, an equal volume of fluid under pressure is automatically displaced through the choke.

## AUTOCHOKE control console

The AUTOCHOKE console is constructed of stainless steel and is complete with drill pipe and casing-pressure gauges, a hydraulic oil pump control regulator, a hydraulic oil set-point gauge, and a hand-operated hydraulic backup pump. The AUTOCHOKE console is equipped with an electronic position indicator, digital pump-stroke counters with a rate meter, stop watch and clock.

## Features and Benefits

- Multiple pressure ratings available
- Automatically maintains casing pressure
- High Capacity
- Downstream choke-bore protection
- Long-life materials
- No-leak shut-in seals

# LOW PRESSURE AUTOCHOKE CONSOLE (LPAC)



The M-I SWACO LOW PRESSURE AUTOCHOKE<sup>†</sup> CONSOLE (LPAC<sup>†</sup>) system provides operators precise wellbore pressure control in underbalanced (UBD) and managed-pressure drilling (MPD) operations.

Maintaining tight control of bottomhole pressure is critical to successful application of MPD and UBD techniques, especially in managed pressure drilling where the window of operation is often significantly narrower than in conventionally drilled wells. Keeping the bottom hole pressure above the pore pressure and wellbore stability thresholds, and below the formation fracture gradient often requires highly accurate control to avoid losses or damage to the wellbore.

The combination of the LPAC unit and the specially designed AUTOCHOKE<sup>†</sup> gives drillers a new level of control over the wellbore pressure profile during UBD and MPD operations. The LPAC unit works at a higher resolution so choke operators have control of pressure accuracy within a range of +/- 50 PSI.

## Features

- Accurate control at lower pressures
- Helps to maintain wellbore pressure within narrow limits
- Operates two AUTOCHOKE units simultaneously
- Small-footprint remote HMI unit in driller's cabin
- Touch screen panel on both Local HPU and Remote HMI
- Increased gauge resolution and digital readouts
- Accumulator and power backup

## Benefits

- Near-constant bottomhole pressure control during UBD/MPD applications
- Precision control for stripping pipe in and out of the hole
- Reduces fluid losses and NPT.
- Helps to avoid pressure-control incidents
- Ability to maintain a tighter pressure window while drilling could eliminate the need for an extra casing string
- Ability to seamlessly transition between chokes
- Chokes can continue to operate for up to two hours after loss of rig air and one hour after loss of rig power
- Remote unit can be placed next to the driller for better communication with the choke operator
- Touch screen allows precise pressure inputs to the chokes
- Digital readouts reduce errors in pressure readings and pressure inputs



# ECHOKE



The ECHOKE<sup>†</sup> unit incorporates an electric actuator, a local drive box and the electronic remote console. The ECHOKE unit is an electronic replacement for the SUPERCHOKE hydraulic console and actuator.

The M-I SWACO ECHOKE was especially designed for precise trouble-free operation. The Remote panel in the doghhouse allows the operator to control choke movement speed and opening position remotely. As well, all the necessary information needed by the operator to control a well situation is displayed on an LCD display panel such as pump speeds, drill and casing pressures, and choke position. The large 6 inch analog gauges allow the operator to get relative pressure changes at a glance. The Local panel is located in the manifold and directly controls the actuator. The Local panel also displays the same information as the Remote, allowing full electronic well control functionality from the manifold. In the manifold the operator has the option of electronically controlling the choke from the Local panel, or switching to manual mode and controlling the choke from the actuator through a hand wheel.

## Features and Benefits

### High-pressure rating

- Built to handle 10,000 and 15,000 psi (689 to 1,034 bar)

### Cold weather

- The electric motor and electronic console replace the air-over-hydraulic console and improve reliability in cold-weather environments

### Small footprint

- The electronic console's quiet and space-saving design allows the console to be located in the driller's cabin

### Reduced cabling requirements

- The ECHOKE unit requires only one communication cable between the remote and local console

### Three modes of operation

- Remote at driller's console
- Local at the choke manifold
- Manual at the choke itself, using the hand-wheel

### High torque

- The ECHOKE system is capable of more than 19,400 in.-lb (2,191.9 Nm) torque. It can sever a ½-in. (12.7 mm) alloy steel rod and still achieve the full-close position

### Variable-speed drive

- The operator can control the speed at which the choke is opened or closed, giving the operator precise choke-positioning adjustment during critical well-control situations

### Faster open/close speeds

- Eight seconds from full-open to full-close. This time exceeds that of a hydraulically actuated choke in cold-weather environments

### Enhanced communication capability

- The ECHOKE system records data via Ethernet to external data-acquisition systems, greatly enhancing the ability to evaluate frac flow-backs, well-control problems, and leak-off tests in real time

The ECHOKE unit is the M-I SWACO standard ECHOKE unit; it incorporates an electric motor actuator and an electronic console.

# SUPERCHOKE

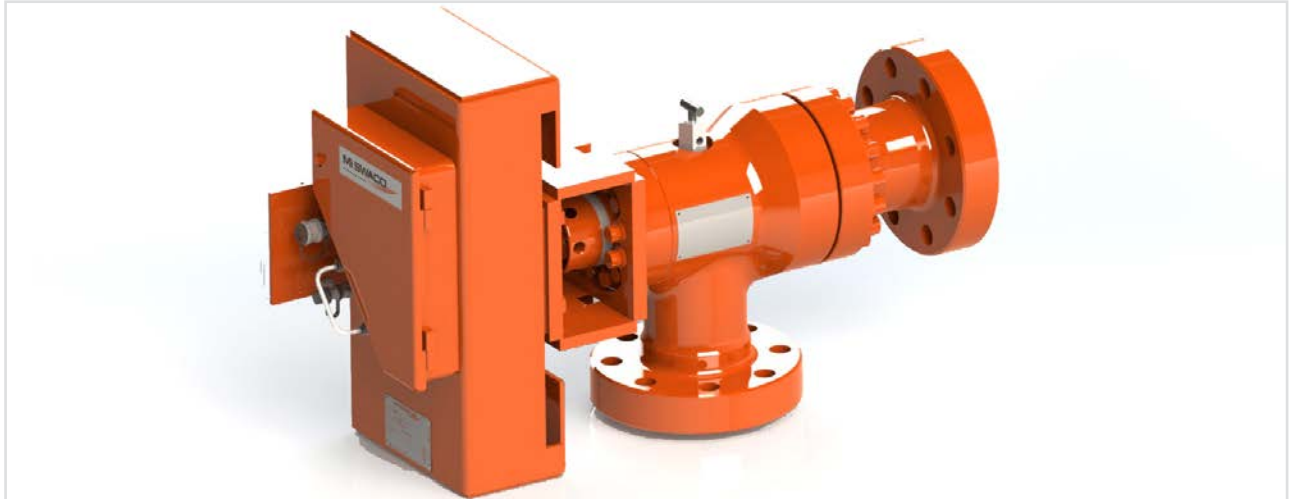

Widely used and respected for well-kill and high-pressure drilling, the M-I SWACO SUPERCHOKE<sup>†</sup> product line is especially effective in well control, well testing, and well cleanup operations. These chokes are effective in H<sub>2</sub>S and abrasive-fluid applications.

## Control consoles

M-I SWACO choke-control consoles are available to control either a single or twin SUPERCHOKE unit. These consoles are equipped with either standard or optional digital gauges. Hydraulically operated consoles are self-contained and skid-mounted for easy installation on or near the rig.

A key feature of the consoles are the large, easy-to-read gauges which monitor critical drill-pipe and casing pressures.

## Features and Benefits

### High-pressure rating

- Built to handle 5,000 to 15,000 psi (345 to 1,379 bar)
- 5,000 psi (345 bar)
- 10,000 psi (689 bar)
- 15,000 psi (1,034 bar)

### Dependable choke-disc design

- Heavy-duty, diamond-lapped tungsten-carbide discs honed to near-perfect flatness. Also feature half-moon-shaped orifices. Rotation of actuator fork allows finite regulation of the opening size from full-open to full-close

### Positive closure

- A 17° deadband overlap beyond the full-close position ensures closure even if the plates become worn following extended exposure to abrasives-laden fluid flow. Quality of the seal is not affected by pressure drops and surges. In fact, the seal improves under pressure

### Tungsten-carbide sleeves

- Increase in-service life. Extended-wear sleeves absorb the effects of abrasive downstream turbulence and protect the API ring gasket

### Versatility

- Ideal for onshore and offshore applications. Controls can be operated from either primary or optional auxiliary consoles

### Three operating modes

- Normal. Activation is rig-air operated.
- Lost rig air. Activation is manual with hydraulic pump located on remote-control skid
- Severed hydraulic lines. Activation is manual with bar provided on indicator head

### Compliance

- Constructed for H<sub>2</sub>S service. M-I SWACO is licensed to manufacture drilling chokes and consoles under API 6A and 16C and in compliance with NACE MR-01-75

# VERSA-CHOKE



The highly flexible VERSA-CHOKE<sup>†</sup> is ideally suited for high-end pressure management, managed pressure drilling (MPD), underbalanced drilling (UBD), frac plug drill-outs and frac flowback.

The position-based VERSA-CHOKE is controlled by a specially designed hydraulically driven worm-gear actuator. Unique to the modular VERSA-CHOKE is the capacity to easily “hot swap” the actuator without having to disassemble any internal components, thereby reducing maintenance time.

Two styles of hydraulic actuators are available, a piston-style actuator for use on the 5K VERSA-CHOKE and a worm-gear style for use on any pressure VERSA-CHOKE. In case of extreme situations, both actuator styles are designed to withstand, without failure, the full working pressure on the outlet of the choke. Available in reversible 1½, 2 and 3-in. trim sizes, the VERSA-CHOKE carries an API P-X (-20°F to 350°F) temperature rating.

## Features

- 5K, 10K, and 15K MAWP (maximum allowable working pressure) ratings
- P-X temperature rating: -20° to 350°F
- Position-based control (worm-gear or piston-style hydraulic actuators available)
- Hot-swappable actuators
- Reversible 1½, 2 and 3-in trim sizes
- Modular design and easily replaceable components
- API 6A Performance Requirement PR2 (optional)
- All available actuators will withstand full MAWP applied to the outlet of the choke
- API flange sizes up to 4¼-in
- Quick-change internal components
- Designed, manufactured, and monogrammed in accordance with API 6A and 16C

## Benefits

- Effective in wide range of pressures and temperatures
- Ability to reverse trim significantly improves choke operation life and reduce maintenance costs
- Spool length and size can be configured to meet custom applications
- Trim can be changed from 1½ to 2 to 3-in by only changing internal components
- Gantry arm promotes ease of maintenance
- Actuators withstand full back pressure
- Safe solution for high-pressure applications

# CHOKE MANIFOLD



The CHOKE MANIFOLD<sup>†</sup> is the standard use manifold for choke and kill operations and performing managed pressure drilling (MPD) or underbalanced drilling (UBD) operations.

The manifold is designed to direct flow from the well through the drilling chokes during a well control situation, for example when operators have to circulate out a kick, or during MPD/UBD operations when the choke is used to control surface casing pressure.

The typical manifold configuration allows the choke and manifold operator to shut the gate valves on one leg of the manifold and service the choke while the flow is directed to another leg of the manifold. Available options include double block and bleed configurations, buffer chambers and custom skid designs.

All offerings are designed to meet NACE MR0175 and API 6A for H<sub>2</sub>S service. Choke and kill manifolds are monogrammed in accordance with API 16C.

The M-I SWACO CHOKE MANIFOLD is available in the following pressure ratings: 5,000, 10,000, and 15,000 psi, depending on the application. Well control manifolds are usually pressure rated for 10,000 or 15,000 psi WP, MPD/UBD manifolds are pressure rated usually 5,000 psi WP.

## Features

- ISO 9001 and ISO 14001 certification
- Space saver, small footprint available
- Four point lifting and integral forklift pockets
- Double block and bleed available
- Buffer tanks available
- All components manufactured and monogrammed to API 6A, PSL3, temperature class P X and material class EE
- Suitable for H<sub>2</sub>S

## Benefits

- Fully mobile for easy placement and movement
- Safe, offline choke and component change outs
- Provides better control of downstream flow
- Slotted U-bolt base under buffer tank for easy removal
- Sensor ports available for pressure and temperature transducers or gauges, sample and chemical injection



# Integrated Package Delivery



Reduce risk. Lower costs. Get measurable, improved results on your next project. Those are the exact results that the M-I SWACO Integrated Package Delivery (IPD) capabilities deliver through integrated mud mixing, fluids processing, drilling and Drilling Waste Management (DWM).

We can apply this integration to our drilling and DWM product lines across the globe, helping you succeed in harsh environments, where extended life requirements of assets and facilities matter most, where QHSE issues demand continual close attention, and where it makes good business sense to reduce spares.

As the world's largest supplier of drilling and completion fluids and drilling waste management equipment, M-I SWACO can take you from flowline to ultimate reuse or disposal as a logical extension of our vast knowledge of fluid technology and management. Our Aberdeen-based IPD organization manages the design, procurement, manufacture, installation and commissioning of custom-built, integrated equipment packages for M-I SWACO operations worldwide.

The team also has offices in Houston, Stavanger, Volgograd and Singapore.

## What M-I SWACO IPD can do for you

While it is an accepted fact that the use of modern technology can significantly reduce E&P costs, operators and service companies are still faced with the burden of identifying and then applying the optimum technologies for project needs.

The decision to evaluate a project in detail from start to finish, followed by strategic management, can help the operator reduce costs and increase operational efficiency.

Our experienced multidisciplinary team delivers integrated packages of equipment for the management of drilling and completion fluids, oil and synthetic-coated drilled cuttings as well as production and well flowback waste streams.

## Features and Benefits

- Meet goals faster and more efficiently through informed, up-to-the-minute engineering decisions
- Achieve higher-quality results from improved project insight
- Maximize the drilling fluids program through detailed engineering equipment design and process
- Reduce non-productive time through remote control and monitoring
- Mitigate QHSE incidents through preliminary planning, removal of personnel from hazardous environments and consistent documentation
- Realize gains from strategically located M-I SWACO IPD networks

# Integrated Package Delivery (Continued)

## Capabilities with strong benefits for you

Much has changed in our industry, and M-I SWACO has actively embraced the integrated-project concept that has emerged in recent years. To provide customized, value-added solutions with a guarantee of technical integrity and quality of work, our IPD division performs in-depth examination of your project, merging management skills with appropriate technologies. Our scope of equipment and process-control services is configured to serve you first and foremost.

## Making technology and engineering work for you

We have learned what is important to you. We've been involved since the 1980s when modifications to equipment were necessary to meet the stringent regulations for North Sea operation. Because we've experienced firsthand the growing sensitivity to QHSE issues associated with rig construction, M-I SWACO has rapidly expanded IPD services to meet ever-increasing demands such as CE/ATEX and NORSOK compliance in the North Sea and international standards and country regulations in the Caspian Sea and eastern Russia.

As the economic stakes of drilling and production rise, more operators are taking a second look at project-specific bulk-handling and drilling waste management packages.

It's a way of controlling costs in the face of challenging demands such as:

- Harsh environments
- Extended-life requirements
- Spares reduction
- Environmental regulations
- Health and safety issues



The M-I SWACO Integrated Package Delivery group is dedicated to producing project-specific, fit-for-purpose equipment packages, including drilling waste management and mud-mixing systems, for new and refurbished drilling installations.

While we design, engineer and manufacture equipment to suit your needs, the team also works to reduce costs through commonality of materials and spares in addition to providing consistent documentation. Clients around the world have discovered that the benefits from IPD services, such as improved safety, regulatory compliance, reduced costs and improved overall efficiency offset all upfront requirements. Integrated controls deliver improved safety, efficiency and economics

Human-Machine Interface (HMI) systems are becoming increasingly common features in modern drilling installations. They can be designed to operate in standalone mode, or can be integrated into the drilling-rig manufacturers' other control systems. The outputs from these systems, including alarms, are available to the operator, driller, and loggers and M-I SWACO personnel.

HMI systems allow operators to set performance parameters, or preset timed operations, for equipment that previously had to be manually operated and monitored. Benefits include a significantly improved working environment, keeping workers out of potentially hazardous environments, reducing personnel requirements, and improving equipment performance.

We use systems-control hardware and software that enables remote control and monitoring of all our main equipment packages. Reliable remote monitoring from either shore-based or corporate facilities is a growing reality.

Benefits now being witnessed by various global operators include:

- Improved operating safety from remote control
- Efficient equipment adjustment and control
- Efficient mixing and blending of chemicals into mud systems
- Minimal exposure of personnel to potentially hazardous areas through remote detection of equipment failure or inoperability
- Reduced onsite personnel requirement as a result of remote diagnostics

#### **Smoother operations begin with project-specific documentation**

Documentation becomes particularly important toward helping equipment operators get the most from the systems we design, build and manufacture. To address this issue, another core activity of the IPD team is to produce project-specific documentation that accompanies each of the packages.

We provide:

- A Supplier Master Documentation Schedule (SMDS) that can include up to 600 documents for complex projects
- A data-collection tool that captures information of every tag detail within the scope of supply
- Project-specific user manuals
- Project-assurance manuals

#### **Maximum value on location**

Take advantage of our global reach. We have operations in the U.S., Europe, the Middle East, Africa and the Asia Pacific region. Each regional base offers our full range of services to meet your local project requirements.

We recognize that our clients are searching for solutions to meet the needs of projects with a multicountry profile. Take the next step in fluids assurance and solids control. Seamless operations from technical integrity and quality are the result of these high-performance engineering packages.





# Solid Control, Cuttings Management and Fluids Processing



[slb.com/drilling](http://slb.com/drilling)

**Mi SWACO**  
A Schlumberger Company