

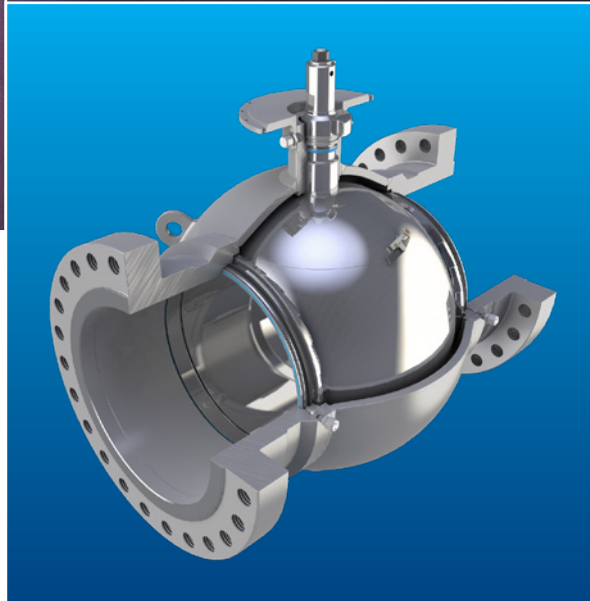

CAMERON T30 Series

Fully welded ball valves





CAMERON T30 Series* fully welded ball valves feature a forged, seal-for-life ball valve design compliant with the latest environmental standards, with field-proven reliability and extended operational service life. These valves are extensively tested and certified to fugitive emissions standard ISO 15848-1 and API Standard 641.

Content

CAMERON T30 Series fully welded ball valves

Introduction	2
Features and benefits	4
Standard T31 seat design	6
Alternative T32 seat design	7
Accessories	8
How to order	9
Standards, specifications, and materials	10
Dimensions	11
ASME Class 150 to 2500 [PN 20 to PN 420] full- and reduced-port valves	12
API pressure class 2,000-, 3,000-, and 5,000-psi full- and reduced-port valves	25
Dimensional data	27
Top works dimensions	28



Ville Platte, LA, USA.

About Cameron, a Schlumberger Company

Cameron is a leading provider of valves and valve automation to the oil and gas industry. Our products are primarily used to control and direct the flow of oil and gas as it is moved from individual wellheads through flowlines, gathering lines, and transmission systems to refineries, petrochemical plants, and industrial centers for processing.

We provide a wide range of valves for use in upstream, midstream, and downstream applications for both gas and liquid products. Cameron, looking to strengthen its single-source capabilities for a wide scope of customer requirements, has developed the traditional CAMERON T30 Series fully welded ball valve product line with the GROVE* valves, RING-O* subsea valves, TOM WHEATLEY* check valves, and ENTECH* nozzle check valves product lines.

Cameron also provides critical service valves for production, refinery, chemical, and petrochemical processing businesses and for associated storage terminal applications, particularly through the ORBIT* rising stem ball valves and GENERAL VALVE* plug and diverter valves product lines. These brands are complemented by WKM* valves and TEXSTEAM* plug valves, which considerably expand the scope of our product offerings.



Overview

One of the most trusted valves in the petroleum industry for more than 50 years, the CAMERON T30 Series ball valve is a bidirectional, trunnion-mounted ball valve with a lightweight spherical body design and superior stem seal design compliant with fugitive emission regulations. Its unique design increases service life, reduces leak paths, and resists pipeline pressures and stresses.

CAMERON T30 Series ball valves are available in pressure classes ASME 150 to 2500 [PN 20 to 420] and API 2,000 to 5,000 psi. Made of forged steel to ensure uniform fine-grain structure and toughness, they can be specified in sizes from NPS 2 to 56 [DN 50 to 1,400].

Engineered for heavy-duty, maintenance-free usage, the CAMERON T30 Series ball valve is commonly selected for a number of applications, including

- gas transmission
- product pipelines
- measurement skids
- dehydration systems
- gas separation systems
- natural gas storage
- dryer service
- NGL plants
- NGL pipelines
- compressor stations
- CO₂ services
- offshore
- subsea.



Features and Benefits

The distinctive design of the CAMERON T30 Series ball valve gives it strength at reduced weight as well as resistance to both pipeline pressures and stresses. The compact, spherical design eliminates body flanges, reducing overall size and potential leak paths. The design also has a smaller volume in the body cavity, minimizing the loss of product during body pressure relief.

Standards and Specifications[†]

Sizes	2 to 56 in [DN 50 to 1,400] full, reduced, and venturi bore
Pressure classes	ASME Class 150 to 2500 [PN 20 to PN 420] API 2,000 to 5,000 psi
Operating temperatures	-50 to 375 degF [-46 to 190 degC]
End connections	Flanged, weld and weld-by-flange, and more
Body styles	Fully welded
Standard material	Forged carbon steel
Optional materials	Seat and seal trim options include regular, corrosion resistant, and sour (NACE MR0175)

[†]See page 10 for specification details.

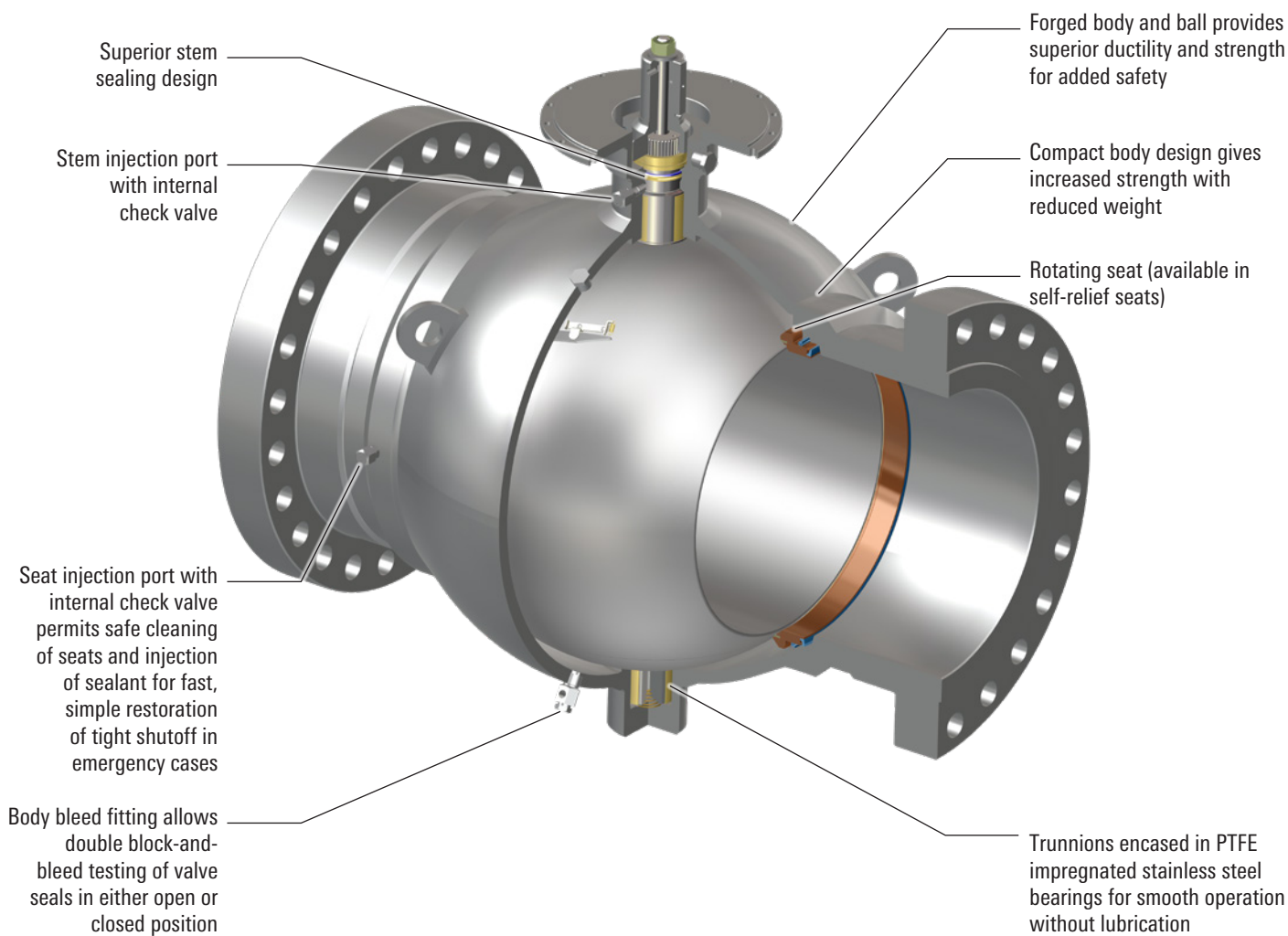

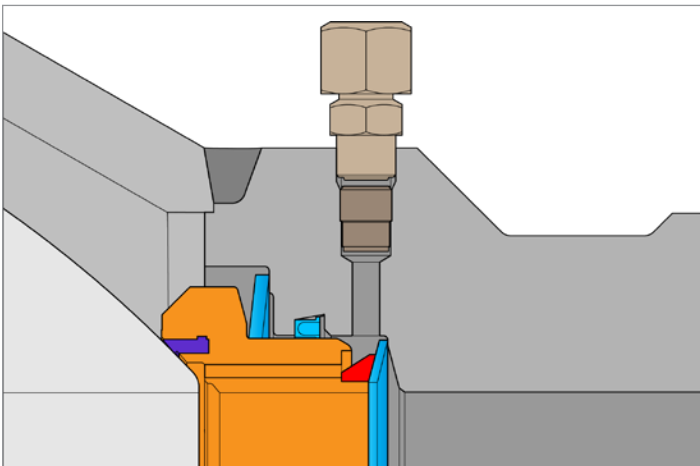
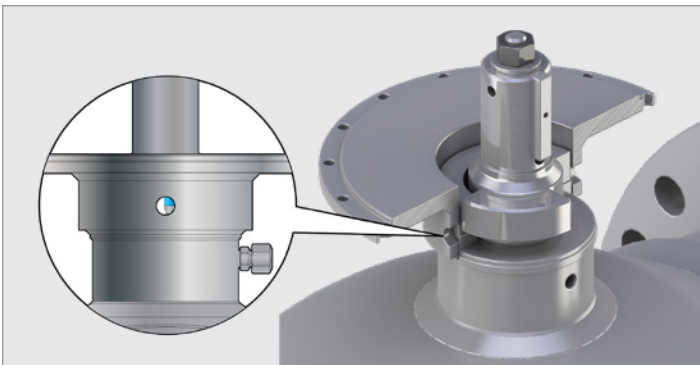
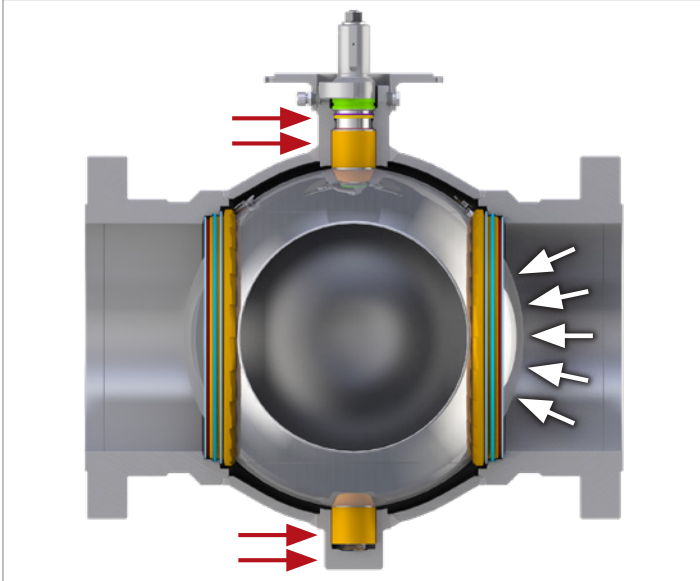
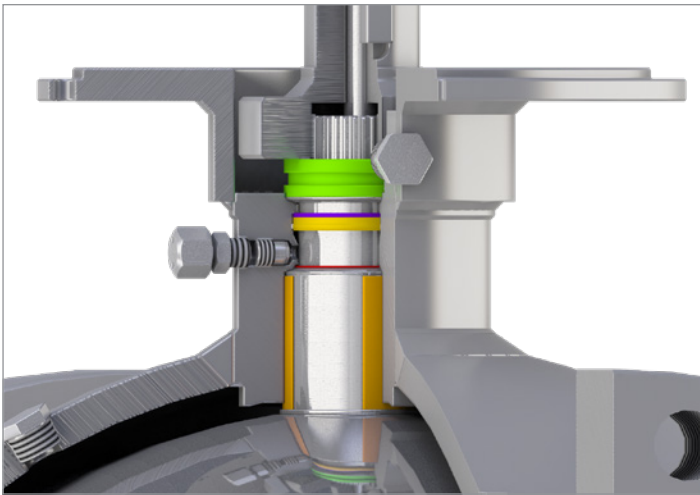

Superior stem sealing performance

CAMERON T30 Series valves include an adjustable and replaceable seal in an antiblowout stem design. Delta seals and lip seals made of PTFE are incorporated in the upper stem area. PTFE is a low-friction, nondeteriorating material that is not subjected to rapid decompression explosion. Most valve sizes have a provision for the sealant injection to establish a secondary seal and an internal check valve for additional safety.

In the unlikely event of a stem leak, tightening the stem nut will correct the problem. In addition, the upper stem seal can be replaced safely with the valve in service after having vented all pressure from the body cavity.

Low emissions

These valves have been extensively tested and certified to fugitive emissions standards API Plan 61 and ISO 154848-1 class BM for applications from -50 to 375 degF [-46 to 191 degC] and Class BH for applications at -50 to 250 degF [-46 to 121 degC].

Reduced cost of ownership

The spherical design of the valve minimizes material for a lower weight, decreases costs for installation and transportation, and is designed for minimal maintenance, which improves production uptime. The welded body also eliminates body flanges, reducing overall size and potential leak paths.

Fire tested for safety

All valves are fire safe compliant to API Standards 6FA and 607 or ISO 10497.

Trunnion-mounted ball for low-torque operation

High-strength forged stems are located in PTFE impregnated stainless steel bearings for smooth, accurate operations. Trunnion-mounted stems absorb the thrust from line pressure, preventing excess friction between the ball and seats, so even at full-rated working pressure, operating torque stays low.

Double block and bleed

This feature allows the verification of the integrity of both seats by blowing down the pressure from the body cavity. This can be done in either fully closed or fully open positions in case fluid transport cannot be disrupted.

Simplified seat injection

The seat injection system provides a fast and simple way of restoring tight shutoff by flushing the sealing surfaces. This feature can also be used for sealant injection if required.

Robust stem stops

Valve stops are integral to the body in a design that withstands actuator torque and helps to accurately set actuator stops in both closed and open positions.

Verifiable valve position

Stem stop viewports enable verification of ball positions at all times, which further increases the accuracy of actuator stop settings.

Improved protection with Belleville springs

The Belleville springs have circumferential contact with the seat and body, maintaining constant spring force and protecting the seat-to-body seal from debris.

Standard T31 Seat Design

In service since the early 1960s, the standard seat arrangement is a proven sound design.

Features and benefits

Upstream sealing

At low pressure, seat-to-ball contact is maintained by Belleville springs. Belleville springs also protect the sealing area from ingress of particles. At higher pressures, seat contact is reinforced by line pressure.

Automatic internal relief of body pressure

Relief of excess body cavity pressure is automatic, avoiding dangerous pressure buildup. Any pressure exceeding downstream line pressure and pressure resulting from spring force pushes the downstream seat away from the ball, allowing the pressure to relieve into the pipeline. This design delivers full protection to the valve body, prevents leaks, and enhances safety in case of fire.

No elastomers

Nylon, PTFE, Tefzel™, or PEEK® polymer seat seals are not subject to explosive decompression or aging effects and have a low friction coefficient for long service life.

Antiblowout seat insert retention

Because of its mechanical retention of the insert, the CAMERON T30 Series valve can be used at high pressures and at low and high temperatures. The valve can be operated under full differential pressure and is suitable for quick operating time.

Rotating seat rings

The exclusive rotating seat feature is standard in CAMERON T30 Series ball valve size 14 in [350 mm] and larger. Both seats rotate 15° each time the valve is closed, delivering the following benefits:

- Distributes seat wear. Evenly distributing wear over 360° prevents the creation of a pinch point, substantially increasing seat life.
- Prevents buildup. As the seat rotates, it prevents buildup from occurring or breaks up existing buildup, ensuring proper floating and hence full seating contact of the seat rings.
- Simplifies maintenance. The rotation improves efficiency of grease, flush, or sealant that is injected by distributing it evenly across the full circumference.

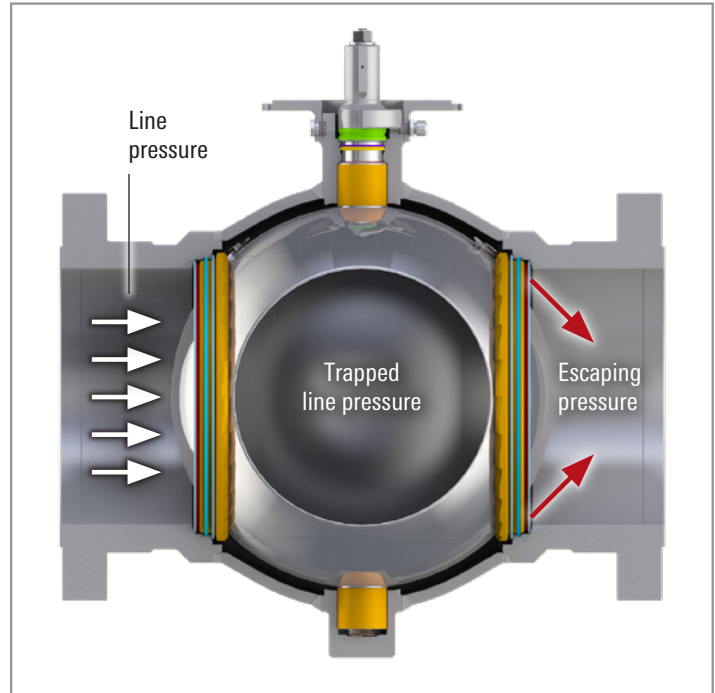

Automatic internal relief of body pressure.

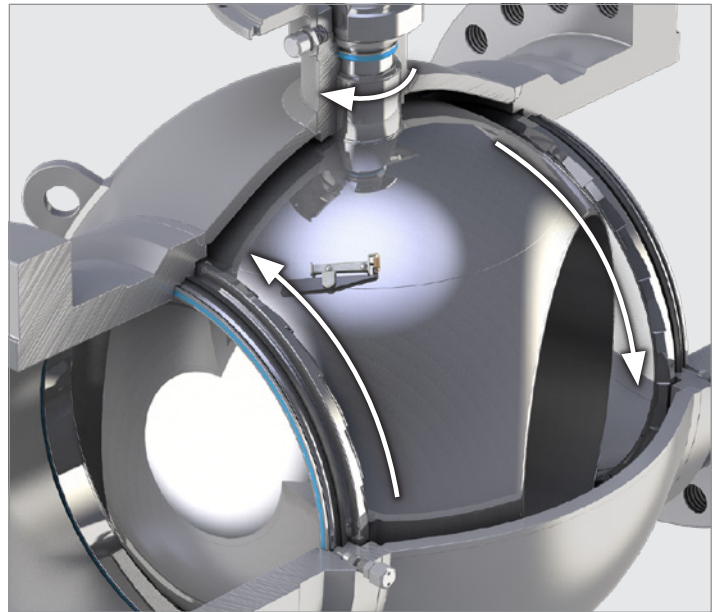

Rotating seat rings.

Alternative T32 Seat Design

The CAMERON T30 Series valve is available with double-piston-effect seats to accommodate a variety of applications and customer preferences.

Features and benefits

Conventional upstream sealing

With upstream pressure, the body-to-seat seal is pushed against the ball by the line pressure through the piston effect.

Downstream sealing

If the pressure in the body cavity is higher than the downstream pressure, the seat-to-body seal shifts, and the piston effect is reversed, maintaining the downstream seat against the ball. With this design, the valve has a double isolation and bleed (DIB) between the upstream and downstream sides of the valve.

Double-piston effect with self relief

This configuration is also available for applications requiring double isolation in one flow direction and internal body cavity self relief in the opposite flow direction — e.g., protection of a platform, refinery, or other assets.

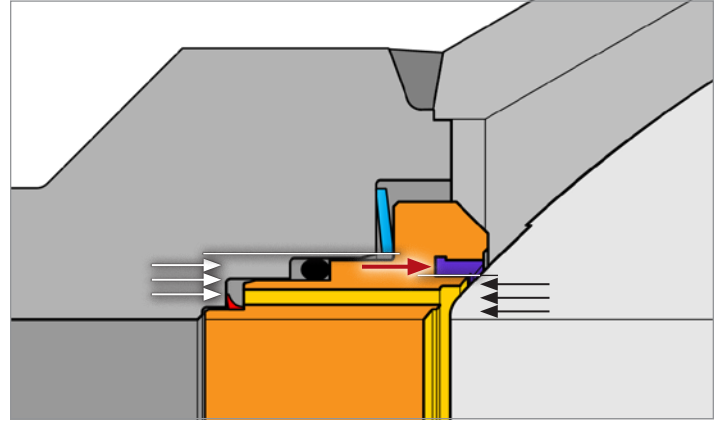

Conventional upstream sealing.

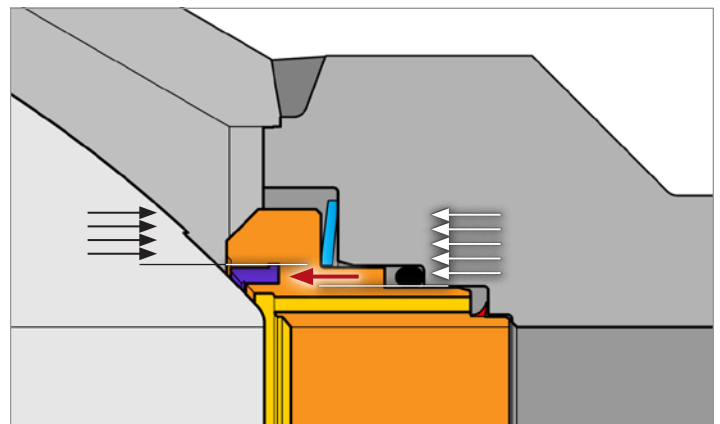

Downstream sealing.

T31 and T32 Available Sizes

Size, in [mm]	ASME Pressure Class						
	150	300	400	600	900	1500	2500
2 [50]	●	●	●	●	●	●	●
3 [80]	●	●	●	●	●	●	●
4 [100]	●	●	●	●	●	●	●
6 [150]	●	●	●	●	●	●	●
8 [200]	■	■	■	■	■	●	●
10 [250]	■	■	■	■	■	●	●
12 [300]	■	■	■	■	■	●	●
14 [350]	■	■	■	■	■	●	—
16 [400]	■	■	■	■	■	●	—
18 [450]	■	■	■	■	■	●	—
20 [500]	■	■	■	■	■	●	—
22 [550]	■	■	■	■	■	●	—
24 [600]	■	■	■	■	■	●	—
26 [650]	■	■	■	■	■	—	—
28 [700]	■	■	■	■	■	—	—
30 [750]	■	■	■	■	■	—	—
32 [800]	■	■	■	■	■	—	—
34 [850]	■	■	■	■	■	—	—
36 [900]	■	■	■	■	■	—	—
42 [1,050]	■	■	■	■	—	—	—
44 [1,000]	■	■	■	■	—	—	—
46 [1,150]	■	■	■	■	—	—	—
48 [1,200]	■	■	■	■	—	—	—
56 [1,400]	■	■	■	■	—	—	—

● T31 standard design.

■ T31 and T32 designs available.

— Not available.

Accessories

Accessories are available to improve the CAMERON T30 Series ball valve's adaptability for a variety of situations.

Stem extension for remote operation

For situations in which the CAMERON T30 Series ball valve must be underground, the high head makes the controls accessible above ground. Additional options such as stub-up and auxiliary valves are available. Designed and constructed to withstand harsh environments, it has proved itself in uses all over the world for many years.

Transition pieces

Cameron can weld transition pieces to the valve during the manufacturing process. Transition can be supplied by the customer or by Cameron to suit the customer's specifications. A wide variety of weld procedures are offered in accordance with international standards.

Right angle improves flexibility

CAMERON T30 Series ball valves can be specified for tight spaces when fitted with a right-angle extension. The valve control is turned 90° from its usual position, allowing more space at the top of the valve and better access by operators.

Gears and actuators optimize performance

To complement the operational excellence achieved in our manufactured valves, Cameron offers actuation and gear technologies such as LEDEEN* actuators, MAXTORQUE* high-performance valve products, and DYNATORQUE* valve accessories. Other brands are also available upon request.

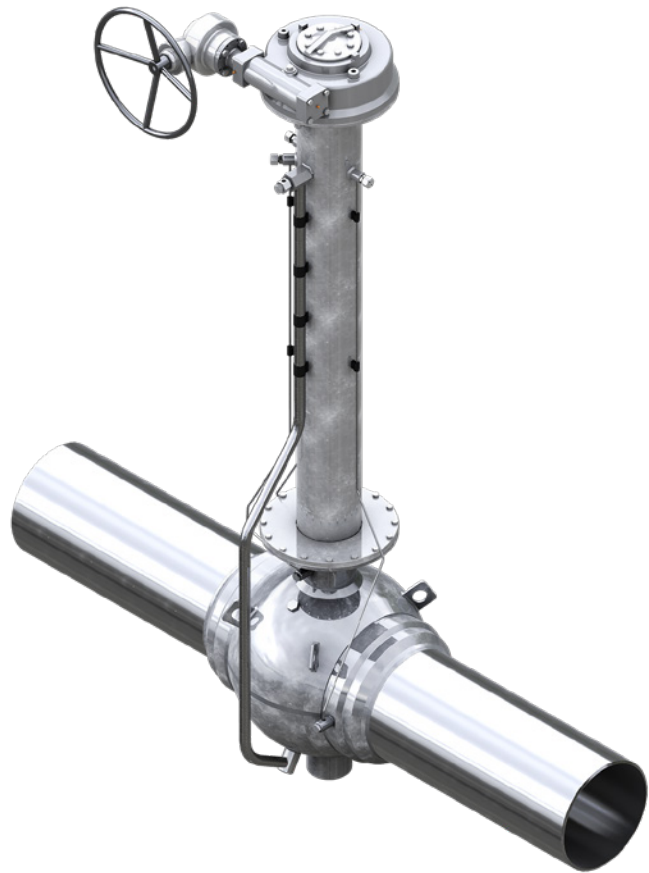

Stem extension and transition pieces for remote operation.



Shallow-water subsea configuration.

How to Order

Specify the following when ordering a CAMERON T30 Series ball valve:

1. Valve figure number (see chart below)
2. Pressure classification (ASME 600, API 3,000 psi)
3. End and bore sizes
4. Type of end connections (unequal ends can be furnished). For weld end valves, specify ID or OD, wall thickness, and grade of pipe
5. Type of operator
6. Stem extension, if desired. Specify distance from valve centerline to center of handwheel, or top of power operator mounting flange
7. Type of trim or application.

Note: Specify any accessories, from lifting eyes, locking devices, and more. Handwheels are included with gearboxes. Operating levers must be ordered separately. Information on special trims and API configurations are available upon request.

Specify the following when ordering another manufacturer's power operator to fit a CAMERON T30 Series ball valve:

1. Valve size and pressure class and, if for field conversion, the present operator
2. Maximum differential pressure across valve during operation and any abnormal operating conditions
3. Speed of opening and closing, probable frequency of operation
4. Type of operator desired (electric, hydraulic, pneumatic)
5. Information on power supply. (If electric: voltage, frequency, single- or three-phase, open- or explosion-proof motor. If hydraulic or pneumatic: operating medium and pressure.)
6. Accessories and controls (limit switches, valving, instrumentation, tanks, pumps, etc.)

How to order example: API Spec 6D, ASME 600, full bore, RF end connections, worm gear, and standard trim

80060121

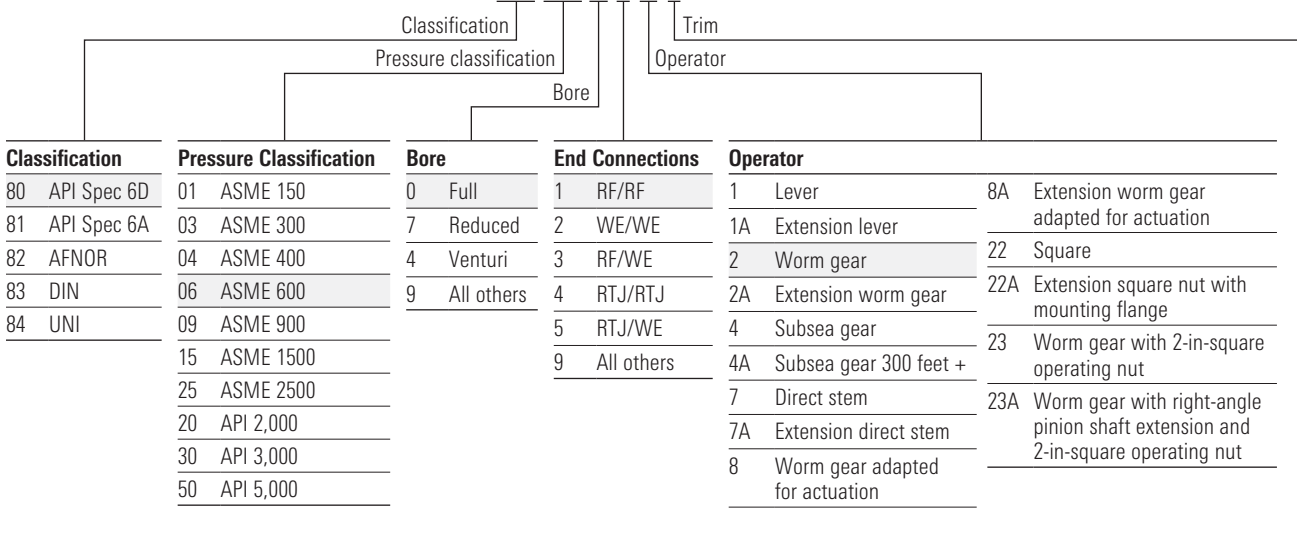

Trim											
US	EUR	Description	Seat Material	Service	ASME	US	EUR	Description	Seat Material	Service	ASME
001	1111	T31 no NACE	Nylon	Standard	150 to 2500	447	-	T31 NACE low-temp	Tefzel	Sour	150 to 2500
004	1113	T31 no NACE	PTFE	Standard	150 to 600	452	1111	T32 no NACE low-temp	Nylon	Standard	150 to 900
008	1111	T31 no NACE low-temp	Nylon	Standard	150 to 2500	454	1311	T32 NACE low-temp	Nylon	Sour	150 to 900
123	-	T31 no NACE low-temp	-	Regulating valve	150 to 1500	459	1341	T32 NACE low-temp 316 inlay	Nylon	Sour	150 to 900
140	1112	T31 NACE	Tefzel	Standard	150 to 2500	-	1343	T31 NACE low-temp	PTFE	High corrosion	150 to 600
214	1312	T31 NACE	Tefzel	Sour	150 to 2500	-	2451	T31 low-temp duplex internals	Nylon	Extreme corrosion	150 to 2500
216	1311	T31 NACE low-temp	Nylon	Sour	150 to 2500	-	2452	T31 low-temp duplex internals	Tefzel	Extreme corrosion	150 to 2500
222	1313	T31 NACE	PTFE	Sour	150 to 600	-	2453	T31 low-temp duplex internals	PTFE	Extreme corrosion	150 to 600
259	1341	T31 NACE low-temp 316 inlay	Nylon	Sour	150 to 2500	-	2454	T31 low-temp duplex internals	PTFE	Extreme corrosion	150 to 2500
438	1314	T31 NACE	PEEK	Sour	150 to 2500	-	3461	T31 low-temp full duplex	Nylon	Extreme corrosion	150 to 2500
415	-	T31 NACE low-temp	Nylon	Low corrosive	150 to 2500	-	1321	T31 No NACE low-temp	Nylon	Ammonia	150 to 2500
466	-	T31 NACE low-temp alloy 625 inlay	Nylon	Deep water	150 to 2500	US trim manufactured in Ville Platte, Louisiana, USA					
607	-	T31 NACE low-temp alloy 625 inlay	Nylon	Shallow water	150 to 2500	EUR trim manufactured in Voghera, Italy					
244	1313	T31 NACE low-temp	PTFE	Sour	150 to 600	EUR trim is equivalent to US trim if both are available					
Other trims available upon request											

Standards, Specifications, and Materials

CAMERON T30 Series ball valves covers a wide range of applications and are qualified and certified according to many standards around the globe. Additional testing and certifications may be available upon request.

Materials

Materials used in ball valve construction are equivalent at all Cameron manufacturing plants. However, the availability of supplies and the need to conform to national standards and to offer various trims may necessitate some variations. In corrosive applications, valve trims may be offered using various types of alloys and

stainless steels. For more information on material specifications and properties, contact your sales representative.

Weld overlays

Cameron valves can be overlaid in case of corrosive service. More frequently used materials are AISI 316L and alloy 625.

Torque information

Contact your sales representative to obtain a copy of the engineering bulletin, which provides detailed torque information for power actuators sizing.



Ville Platte, Louisiana, USA.

Trim Materials

	T31 Trim 001 Standard	T31 Trim 216 NACE	T31 Trim Duplex Internals	T31 Trim Full Duplex	T32 Trim Standard	T32 Trim NACE
Pressure range, ASME Class [PN]	150 to 2500 [20 to 420]	150 to 2500 [20 to 420]	150 to 2500 [20 to 420]	150 to 2500 [20 to 420]	150 to 900 [20 to 150]	150 to 900 [20 to 150]
Temperature range, degF [degC]	-20 to 250 [-29 to 121]	-50 to 250 [-46 to 121]	-50 to 250 [-46 to 121]	-50 to 250 [-46 to 121]	-50 to 250 [-46 to 121]	-50 to 250 [-46 to 121]
Body shell	ASTM A350 LF2 or ASTM A516 Gr70 ¹	ASTM A350 LF2 or ASTM A516 Gr70 ¹	ASTM A350 LF2 or ASTM A516 Gr70 ¹	ASTM A182 F51 (duplex)	ASTM A350 LF2 or ASTM A516 Gr70 ¹	ASTM A350 LF2 or ASTM A516 Gr70 ¹
End connections	ASTM A350 LF2	ASTM A350 LF2	ASTM A350 LF2	ASTM A182 F51 (duplex)	ASTM A350 LF2	ASTM A350 LF2
Ball, stem, trunnion	AISI 4130 or ASTM A694 Gr F50	AISI 4130 or ASTM A694 Gr F50	ASTM A182 F51 (duplex)	ASTM A182 F51 (duplex)	AISI 4130 or ASTM A694 Gr F50	AISI 4130 or ASTM A694 Gr F50
Seat rings	AISI 1040	AISI 410 SS	ASTM A182 F51 (duplex)	ASTM A182 F51 (duplex)	AISI 1040	AISI 410 SS
Barrier ring	Carbon steel	Carbon steel nickel plated or Xylan [®] coated	UNS N07718	UNS N07718	Carbon steel	Carbon steel nickel plated or Xylan coated
Delta seals	PTFE	PTFE	PTFE	PTFE	PTFE	PTFE
Body to seat seal	PTFE	PTFE	PTFE	PTFE	HNBR	HNBR
Seat ring insert	Nylon	Nylon	Nylon	Nylon	Nylon	Nylon
Coating on ball, stem, trunnion	001 ENP	003 ENP	—	—	001 ENP	003 ENP

Trim materials of construction for valves larger than 12 in.

Most common trims shown in table. Trims information is available upon request.

Additional Certifications, Testing, and Spare Parts

Fugitive emissions	API Standard 641
	ISO 15848-1 performance class BM
	ISO 15848-1 performance class BH (need to specified at the time of the order)
	ISO 15848-2 production test
Quality system	Include QSL 1, optional QSL-2, QSL-3, and QSL-4
API testing	API Spec 6D supplementary tests
	API Spec 6DSS testing
	API Standard 598
Regulatory compliance	Safety Integrity Level (SIL) 3 to IEC 61508
	ATEX Directive 2014/34/EU
	Pressure Equipment Directive (PED) 2014/68/EU Module HI
	Eurasian Conformity (EAC) and TR CU standard compliance
	Canadian Registration Number (CRN) system approved
Spare parts	Stem seal and body fittings



Voghera, Italy.

Dimensions

Dimensional Codes for Flanged and Weld Ends (Full and Reduced Openings)

Code	Description
A	End-to-end (length dimension)
B	Bore diameter
C	Centerline to bottom
D1	Flange outside diameter
D2	Flange inside dimension
E	Sphere dimension

Dimensional Codes for Cameron Manual Operators

Code	Description
G	Handwheel diameter
H	Center of bore to top of square nut for lever operated valves, center of bore to handwheel for gear operated valves
L	Center of bore to end of lever

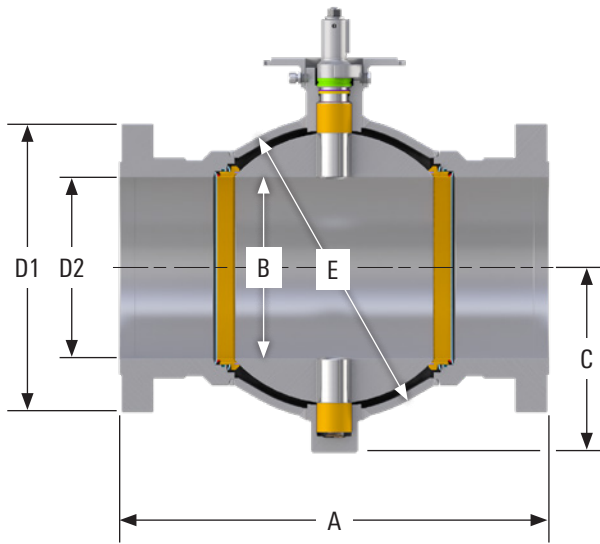

SD-24027.

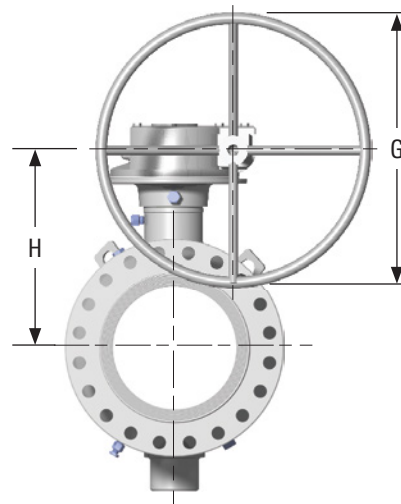

SD-24028.

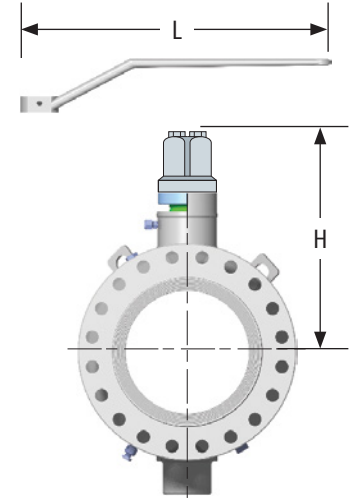

SD-24029.

ASME Class 150 (PN 20)

Full bore

Dimensions														
Size, in			Flanged End [†]				Weld	C.L. to	Body	Lever	Diameter	C.L. to	Approximate Valve	
Nom. Diameter	Ball Bore	Stem Size	RF Length	RTJ Length	Diameter	Diameter	End [†] Length	Bottom	Sphere	Length	Handwheel for Gear	Handwheel C.L.	Weight, lbm	
B			A	A	D1 ^{**}	D2	A	C	E	L	G	H	Flange	Weld
2	2.06	1.0	7.0	7.5	6.00	2.06	11.0 [‡]	3.94	5.00	24	–	6.34	39	45
3	3.13	1.0	8.0	8.5	7.50	3.13	12.5 [‡]	5.12	6.75	24	–	7.44	62	75
4	4.06	1.5	9.0	9.5	9.00	4.06	14.0	5.94	8.50	36	–	8.43	115	100
6	6.00	1.5	15.5	16.0	11.00	6.00	18.0	7.91	11.25	–	12	10.43	200	225
8	8.00	2.0	18.0	18.5	13.50	8.00	21.5 [‡]	10.00	15.50	–	18	12.55	428	450
10	10.00	2.0	21.0	21.5	16.00	10.00	23.5 [‡]	12.12	18.50	–	18	14.54	705	650
12	12.00	3.0	24.0	24.5	19.00	12.00	26.5 [‡]	14.50	22.36	–	18	20.14	1,210	1,100
14	13.25	3.0	27.0	27.5	21.00	13.25	28.5 [‡]	14.64	24.00	–	18	21.16	1,330	1,230
16	15.25	3.0	30.0	30.5	23.50	15.25	30.5 [‡]	16.01	26.32	–	18	22.52	1,650	1,550
18	17.25	4.0	34.0	34.5	25.00	17.25	33.5 [‡]	19.25	29.20	–	24	26.19	2,325	2,200
20	19.25	4.0	36.0	36.5	27.50	19.25	35.5 [‡]	20.81	32.27	–	18	27.75	3,310	2,760
22	21.25	4.0	40.0	40.5	29.50	21.25	38.5 [‡]	22.28	36.00	–	18	29.22	3,875	3,510
24	23.25	4.0	42.0	42.5	32.00	23.25	42.0 [‡]	23.69	38.76	–	18	30.63	4,620	4,260
26	25.00	5.0	45.0	–	34.25	25.00	44.5 [‡]	26.49	41.75	–	24	34.34	6,400	5,600
28	27.00	5.0	49.0	–	36.50	27.00	47.0 [‡]	27.88	44.86	–	24	35.72	7,200	6,500
30	29.00	5.0	51.0	–	38.75	29.00	49.0 [‡]	29.51	47.90	–	24	37.37	9,500	8,800
32	30.75	5.0	54.0	–	41.75	30.75	52.0 [‡]	31.16	52.25	–	24	37.01	††	††
34	32.75	5.0	58.0	–	43.75	32.75	54.5 [‡]	32.16	53.64	–	30	40.01	13,500	12,000
36	34.50	5.0	60.0	–	46.00	34.50	56.5 [‡]	33.76	56.83	–	36	41.60	15,150	14,500
40	38.50	7.5	69.0	–	50.75	38.50	65.0 [‡]	40.14	65.00	–	30	50.25	–	–
42	41.25	7.5	72.0	–	53.00	41.25	66.5 [‡]	41.78	68.60	–	42	51.89	–	–
48	46.50	7.5	80.0	–	59.50	46.50	76.0 [‡]	45.90	77.00	–	–	–	–	–
Size, mm													Weight, kg	
50	52	25	178	191	152	52	279 [‡]	100	127	610	–	161	18	20
80	80	25	203	216	191	80	318 [‡]	130	171	610	–	189	28	34
100	103	38	229	241	229	103	356	151	216	914	–	214	52	45
150	152	38	394	406	279	152	457	201	286	–	305	265	91	102
200	203	51	457	470	343	203	546 [‡]	254	394	–	457	319	194	204
250	254	51	533	546	406	254	597 [‡]	308	470	–	457	369	320	295
300	305	76	610	622	483	305	673 [‡]	368	568	–	457	512	549	499
350	337	76	686	699	533	337	724 [‡]	372	610	–	457	537	603	558
400	387	76	762	775	597	387	775 [‡]	407	669	–	457	572	748	703
450	438	102	864	876	635	438	851	489	742	–	610	665	1,055	998
500	489	102	914	927	699	489	902	529	820	–	457	705	1,501	1,252
550	540	102	1,016	1,029	749	540	978 [‡]	566	914	–	457	742	1,758	1,592
600	591	102	1,067	1,080	813	591	1,067 [‡]	602	985	–	457	778	2,096	1,932
650	635	127	1,143	–	870	635	1,130 [‡]	673	1,060	–	610	872	2,903	2,540
700	686	127	1,245	–	927	686	1,194 [‡]	708	1,139	–	610	907	3,266	2,948
750	737	127	1,295	–	984	737	1,245 [‡]	750	1,217	–	610	949	4,309	3,992
800	781	127	1,372	–	1,060	781	1,321 [‡]	791	1,327	–	610	940	††	††
850	832	127	1,473	–	1,111	832	1,384 [‡]	817	1,362	–	762	1,016	6,123	5,443
900	876	127	1,524	–	1,168	876	1,435 [‡]	858	1,443	–	914	1,057	6,872	6,577
1,000	978	191	1,753	–	1,289	978	1,651 [‡]	1,020	1,651	–	762	1,276	–	–
1,050	1,048	191	1,829	–	1,346	1,048	1,689 [‡]	1,061	1,742	–	1,067	1,318	–	–
1,200	1,181	191	2,032	–	1,511	1,181	1,930 [‡]	1,166	1,956	–	–	–	–	–

[†]Length (A) of a weld x flanged-end valve is one half the sum of length (A) of a weld end and a flange end of the same size and rating.

[‡]Short pattern.

[‡]Length exceeds specified dimensions in API Spec 6D and ISO 14313.

^{**}Dimensions of 22-in [550-mm] flanges are per MSS-SP-44, and 26-in [650-mm] to 42-in [1,050-mm] flanges are per ASME B16.47 series A.

^{††}For additional information, please contact Cameron engineering team.

ASME Class 150 (PN 20)

Reduced bore

Dimensions															
Size, in			Flanged End [†]				Weld End [†] Length	C.L. to Bottom	Body Sphere	Lever Length	Diameter Handwheel for Gear	C.L. to Handwheel C.L.	Approximate Valve Weight, lbm		
Nom. Diameter	Ball Bore	Stem Size	RF Length	RTJ Length	Diagram D1 ^{††}	Diagram D2							A	C	E
			B	A	A	D1 ^{††}	D2	A	C	E	L	G	H	Flange	Weld
3	2.06	1.0	8.0	8.5	7.50	3.13	11.0 [§]	3.94	5.00	24	–	6.34	55	50	
4	3.13	1.0	9.0	9.5	9.00	4.06	12.5 [§]	5.12	6.75	24	–	7.44	100	87	
6	4.06	1.5	15.5	16.0	11.00	6.00	14.0 [§]	5.94	8.50	36	–	8.43	170	150	
8	6.00	1.5	18.0	18.5	13.50	8.00	18.0	7.91	11.25	–	12	10.43	345	290	
10	8.00	2.0	21.0	21.5	16.00	10.00	21.5 [§]	10.00	15.50	–	18	12.55	620	525	
12	10.00	2.0	24.0	24.5	19.00	12.00	23.5 [§]	12.12	18.50	–	18	14.54	950	840	
14	12.00	3.0	27.0	27.5	21.00	13.25	26.5 [§]	14.50	22.36	–	18	20.14	1,280	1,160	
16	13.25	3.0	30.0	30.5	23.50	15.25	28.5 [§]	14.64	24.00	–	18	21.16	1,450	1,330	
18	15.25	3.0	34.0	34.5	25.00	17.25	30.5 [‡]	16.01	26.32	–	18	22.52	1,510	1,700	
20	17.25	4.0	36.0	36.5	27.50	19.25	33.5 [‡]	19.25	29.20	–	24	26.19	2,410	2,300	
22	19.25	4.0	40.0	40.5	29.50	21.25	35.5 [‡]	20.81	32.27	–	18	27.75	3,450	3,050	
24	21.25	4.0	42.0	42.5	32.00	23.25	38.5 [‡]	22.28	36.00	–	18	29.22	4,300	3,650	
26	23.25	4.0	45.0	–	34.25	25.00	42.0 [‡]	23.69	38.76	–	18	30.63	5,400	5,100	
28	25.00	5.0	49.0	–	36.50	27.00	44.5 [‡]	26.49	41.75	–	24	34.34	7,040	6,100	
30	27.00	5.0	51.0	–	38.75	29.00	47.0 [‡]	27.88	44.86	–	24	35.72	8,900	7,600	
32	29.00	5.0	54.0	–	41.75	32.75	49.0 [‡]	29.51	47.90	–	24	37.37	9,600	8,500	
36	32.75	5.0	60.0	–	46.00	34.50	54.5 [‡]	32.16	53.64	–	30	40.01	14,000	12,500	
42	34.50	5.0	72.0	–	53.00	41.25	56.5 [‡]	33.76	56.83	–	36	41.60	–	–	
Size, mm													Weight, kg		
80	52	25	203	216	191	80	279 [§]	100	127	610	–	161	25	23	
100	80	25	229	241	229	103	318 [§]	130	172	610	–	189	45	39	
150	103	38	394	406	279	152	356 [§]	151	216	914	–	214	77	68	
200	152	38	457	470	343	203	457	201	286	–	305	265	156	132	
250	203	51	533	546	406	254	564 [§]	254	394	–	457	319	281	238	
300	254	51	610	622	483	305	597 [§]	308	470	–	457	369	431	381	
350	305	76	686	699	533	337	673 [§]	368	568	–	457	512	581	526	
400	337	76	762	775	597	387	724 [‡]	372	610	–	457	537	658	603	
450	387	76	864	876	635	438	774 [‡]	407	669	–	457	572	685	771	
500	438	102	914	927	699	489	851 [‡]	489	741	–	610	665	1,093	1,043	
550	489	102	1,016	1,029	749	540	902 [‡]	529	820	–	457	705	1,565	1,383	
600	540	102	1,067	1,080	813	591	978 [‡]	566	914	–	457	742	1,950	1,656	
650	591	102	1,143	–	870	635	1,067 [‡]	602	985	–	457	778	2,449	2,313	
700	635	127	1,245	–	927	686	1,130 [‡]	673	1,061	–	610	872	3,193	2,767	
750	686	127	1,295	–	984	737	1,194 [‡]	708	1,139	–	610	907	4,037	3,447	
800	737	127	1,372	–	1,048	832	1,245 [‡]	750	1,217	–	610	949	4,355	3,856	
900	832	127	1,524	–	1,168	876	1,384 [‡]	817	1,363	–	762	1,016	6,350	5,670	
1,050	876	127	1,829	–	1,346	1,048	1,435 [‡]	858	1,444	–	914	1,057	–	–	

[†] Length (A) of a weld x flanged-end valve is one half the sum of length (A) of a weld end and a flange end of the same size and rating.

[‡] Short pattern.

[§] Length exceeds specified dimensions in API Spec 6D and ISO 14313.

^{††} Dimensions of 22-in [550-mm] flanges are per MSS-SP-44, and 26-in [650-mm] to 42-in [1050-.mm] flanges are per ASME B16.47 series A.

Note: Venturi opening or other reduced-bore valves are available upon request.

ASME Class 300 (PN 50)

Full bore

Dimensions														
Size, in			Flanged End ¹				Weld End ¹ Length	C.L. to Bottom	Body Sphere	Lever Length	Diameter Handwheel for Gear	C.L. to Handwheel C.L.	Approximate Valve Weight, lbm	
Nom. Diameter	Ball Bore	Stem Size	RF Length	RTJ Length	Diameter D1 ^{††}	Diameter D2							Flange	Weld
B			A	A	D1 ^{††}	D2	A	C	E	L	G	H		
2	2.06	1.0	8.50	9.125	6.50	2.06	11.0 [§]	3.94	5.00	24	—	6.34	50	45
3	3.13	1.0	11.125	11.750	8.25	3.13	12.5 [§]	5.12	6.75	24	—	7.44	80	75
4	4.06	1.5	12.00	12.625	10.00	4.06	14.0 [§]	5.94	8.50	36	—	8.43	125	100
6	6.00	1.5	15.875	16.500	12.50	6.00	18.0	7.91	11.25	—	12	10.43	250	225
8	8.00	2.0	19.75 ^{††}	20.375	15.00	8.00	21.5 [§]	10.00	15.50	—	18	12.55	455	450
10	10.00	2.0	22.375	23.000	17.50	10.00	23.5 [§]	12.12	18.50	—	18	14.54	750	650
12	12.00	3.0	25.50	26.125	20.50	12.00	26.5 [§]	14.50	22.36	—	18	20.14	1,275	1,100
14	13.25	3.0	30.00	30.625	23.00	13.25	28.5 [§]	14.64	24.00	—	24	21.16	1,370	1,230
16	15.25	3.0	33.00	33.625	25.50	15.25	30.5 [§]	16.01	26.32	—	24	22.52	1,725	1,550
18	17.25	4.0	36.00	36.625	28.00	17.25	33.5 [§]	19.25	29.20	—	24	26.19	2,700	2,200
20	19.25	4.0	39.00	39.750	30.50	19.25	35.5 [§]	20.81	32.27	—	18	27.75	3,400	2,760
22	21.25	4.0	43.00	43.875	33.00	21.25	38.5 [§]	22.28	36.00	—	24	29.22	4,050	3,510
24	23.25	4.0	45.00	45.875	36.00	23.25	42.0 [§]	23.69	38.76	—	24	30.63	5,390	4,260
26	25.00	5.0	49.00	50.000	38.25	25.00	44.5 [§]	26.49	41.75	—	24	34.34	6,625	5,600
28	27.00	5.0	53.00	54.000	40.75	27.00	47.0 [§]	27.88	44.86	—	24	35.72	7,725	6,500
30	29.00	5.0	55.00	56.000	43.00	29.00	49.0 [§]	29.51	47.90	—	30	37.37	10,000	8,800
32	30.75	5.0	60.0	61.130	45.25	30.75	52.0 [§]	31.16	52.25	—	30	37.01	§§	§§
34	32.75	5.0	64.00	65.125	47.50	32.75	54.5 [§]	32.16	53.64	—	36	40.01	14,700	12,000
36	34.50	7.5	68.00	69.125	50.00	34.50	56.5 [§]	36.80	56.83	—	24	46.92	16,300	15,500
40	38.50	7.5	74.00	—	48.75	38.50	65.0 [§]	40.14	65.00	—	36	50.25	—	—
42	41.25	7.5	76.00	—	50.75	41.25	66.5 [§]	41.78	68.60	—	42	51.89	—	—
48	46.50	7.5	86.00	—	57.75	46.50	76.0 [§]	45.90	77.00	—	—	—	—	—
Size, mm													Weight, kg	
50	52	25	216	232	165	52	279 [§]	100	127	610	—	161	23	20
80	80	25	283	298	210	80	318 [§]	130	172	610	—	189	36	34
100	103	38	305	321	254	103	356 [§]	151	216	914	—	214	57	45
150	152	38	403	419	318	152	457	201	286	—	305	265	113	102
200	203	51	502 ^{††}	518	381	203	546 [§]	254	394	—	457	319	206	204
250	254	51	568	584	445	254	597 [§]	308	470	—	610	369	340	295
300	305	76	648	664	521	305	673 [§]	368	568	—	457	512	578	499
350	337	76	762	778	584	337	724 [§]	372	610	—	610	537	621	558
400	387	76	838	854	648	387	775 [§]	407	669	—	610	572	782	703
450	438	102	914	930	711	438	851 [§]	489	742	—	610	665	1,225	998
500	489	102	991	1,010	775	489	902 [§]	529	820	—	457	705	1,542	1,252
550	540	102	1,092	1,114	838	540	978 [§]	566	914	—	610	742	1,837	1,592
600	591	102	1,143	1,165	914	591	1,067 [§]	602	985	—	610	778	2,445	1,932
650	635	127	1,245	1,270	972	635	1,130 [§]	673	1,060	—	610	872	3,005	2,540
700	686	127	1,346	1,372	1,035	686	1,194 [§]	708	1,139	—	610	907	3,504	2,948
750	737	127	1,397	1,422	1,092	737	1,245 [§]	750	1,217	—	762	949	4,536	3,992
800	781	127	1,524	1,553	1,149	781	1,321 [§]	791	1,327	—	762	940	§§	§§
850	832	127	1,626	1,654	1,207	832	1,384 [§]	817	1,362	—	914	1,016	6,668	5,443
900	876	191	1,727	1,756	1,270	876	1,435 [§]	935	1,443	—	610	1,192	7,394	7,031
1,000	978	191	1,880	—	1,238	978	1,651 [§]	1,020	1,651	—	914	1,276	—	—
1,050	1,048	191	1,930	—	1,289	1,048	1,689 [§]	1,061	1,742	—	1,067	1,318	—	—
1,200	1,181	191	2,184	—	1,467	1,181	1,930 [§]	1,166	1,956	—	—	—	—	—

¹Length (A) of a weld x flanged-end valve is one half the sum of length (A) of a weld end and a flange end of the same size and rating.

[†]Short pattern.

[§]Length exceeds specified dimensions in API Spec 6D and ISO 14313.

^{††}Dimensions of 2-in [50-mm] flanges are per MSS-SP-44, and 26-in [650-mm] to 42-in [1,050-mm] flanges are per ASME B16.47 series A.

^{†††}Prior to 1/1/98 and manufactured to 16.5-in [419-mm] short-pattern length.

^{§§}For additional information, please contact Cameron engineering team.

ASME Class 300 (PN 50)

Reduced bore

Dimensions														
Size, in			Flanged End [†]				Weld End [†] Length	C.L. to Bottom	Body Sphere	Lever Length	Diameter Handwheel for Gear	C.L. to Handwheel C.L.	Approximate Valve Weight, lbm	
Nom. Diameter	Ball Bore	Stem Size	RF Length	RTJ Length	Diagram D1 ^{††}	Diagram D2							A	C
B							A	C	E	L	G	H	Flange	Weld
3	2.06	1.0	11.125	11.75	8.25	3.13	11.0 [†]	3.94	5.00	24	–	6.34	64	50
4	3.13	1.0	12.00	12.625	10.00	4.06	12.5 [§]	5.12	6.75	24	–	7.44	95	87
6	4.06	1.5	15.875	16.500	12.50	6.00	14.0 [†]	5.94	8.50	36	–	8.43	180	150
8	6.00	1.5	19.75 ^{††}	20.375	15.00	8.00	18.0 [†]	7.91	11.25	–	12	10.43	365	290
10	8.00	2.0	22.375	23.000	17.50	10.00	21.5 [†]	10.00	15.50	–	18	12.55	650	525
12	10.00	2.0	25.50	26.125	20.50	12.00	23.5 [†]	12.12	18.50	–	18	14.54	1,050	840
14	12.00	3.0	30.00	30.625	23.00	13.25	26.5 [†]	14.50	22.36	–	18	20.14	1,285	1,160
16	13.25	3.0	33.00	33.625	25.50	15.25	28.5 [†]	14.64	24.00	–	24	21.16	1,660	1,330
18	15.25	3.0	36.00	36.625	28.00	17.25	30.5 [†]	16.01	26.32	–	24	22.52	1,990	1,700
20	17.25	4.0	39.00	39.750	30.50	19.25	33.5 [†]	19.25	29.20	–	24	26.19	3,100	2,300
22	19.25	4.0	43.00	43.875	33.00	21.25	33.5 [†]	20.81	32.27	–	18	27.75	3,600	3,050
24	21.25	4.0	45.00	45.875	36.00	23.25	38.5 [†]	22.28	36.00	–	24	29.22	4,500	3,650
26	23.25	4.0	49.00	50.000	38.25	25.00	42.0 [†]	23.69	38.76	–	24	30.63	5,750	5,100
28	25.00	5.0	53.00	54.000	40.75	27.00	44.5 [†]	26.49	41.75	–	24	34.34	7,260	6,100
30	27.00	5.0	55.00	56.000	43.00	29.00	47.0 [†]	27.88	44.86	–	24	35.72	9,100	7,600
32	29.00	5.0	60.00	61.125	45.25	32.75	49.0 [†]	29.51	47.90	–	30	37.37	10,150	8,800
36	32.75	5.0	68.00	69.125	50.00	34.50	54.5 [†]	32.16	53.64	–	36	40.01	15,350	13,000
42	34.50	7.5	76.00	–	50.75	41.25	56.5 [†]	36.80	56.83	–	24	49.92	–	–
Size, mm													Weight, kg	
80	52	25	283	298	210	80	279 [†]	100	127	610	–	161	29	23
100	80	25	305	321	254	103	318 [§]	130	171	610	–	189	43	39
150	103	38	403	419	318	152	356 [†]	151	216	914	–	214	82	68
200	152	38	502 ^{††}	518	381	203	457 [†]	201	286	–	305	265	166	132
250	203	51	568	584	445	254	546 [†]	254	394	–	457	319	295	238
300	254	51	648	664	521	305	597 [†]	308	470	–	457	369	476	381
350	305	76	762	778	584	337	673 [†]	368	568	–	457	512	583	526
400	337	76	838	854	648	387	724 [†]	372	610	–	610	537	753	603
450	387	76	914	930	711	438	775 [†]	407	669	–	610	572	903	771
500	438	102	991	1,010	775	489	851 [†]	489	742	–	610	665	1,406	1,043
550	489	102	1,092	1,114	838	540	851 [†]	529	820	–	457	705	1,633	1,383
600	540	102	1,143	1,165	914	591	978 [†]	566	914	–	610	742	2,041	1,656
650	591	102	1,245	1,270	972	635	1,067 [†]	602	985	–	610	778	2,608	2,313
700	635	127	1,346	1,372	1,035	686	1,130 [†]	673	1,060	–	610	872	3,293	2,767
750	686	127	1,397	1,422	1,092	737	1,194 [†]	708	1,139	–	610	907	4,128	3,447
800	737	127	1,524	1,553	1,149	832	1,245 [†]	750	1,217	–	762	949	4,604	3,992
900	832	127	1,727	1,756	1,270	867	1,384 [†]	817	1,362	–	914	1,016	6,963	5,897
1,050	876	191	1,930	–	1,289	1,048	1,435 [†]	935	1,443	–	610	1,192	–	–

[†] Length (A) of a weld x flanged-end valve is one half the sum of length (A) of a weld end and a flange end of the same size and rating.

[†] Short pattern.

[§] Length exceeds specified dimensions in API Spec 6D and ISO 14313.

^{††} Dimensions of 2-in [50-mm] flanges are per MSS-SP-44, and 26-in [650-mm] to 42-in [1,050-mm] flanges are per ASME B16.47 series A.

^{†††} Prior to 1/1/98 and manufactured to 16.5-in [419-mm] short-pattern length.

Note: Venturi opening or other reduced-bore valves are available upon request.

ASME Class 400 (PN 64)

Full bore

Dimensions													Approximate Valve Weight, lbm		
Size, in			Flanged End ¹				Weld End ¹ Length	C.L. to Bottom	Body Sphere	Lever Length	Diameter Handwheel for Gear	C.L. to Handwheel C.L.	Approximate Valve Weight, lbm		
Nom. Diameter	Ball Bore	Stem Size	RF Length	RTJ Length	Diameter D1 ⁵	Diameter D2	A	C	E	L	G	H	Flange	Weld	
B			A	A	D1 ⁵	D2	A	C	E	L	G	H			
2	2.06		Use ASME Class 600 valves (PN 100)												
3	3.13		Use ASME Class 600 valves (PN 100)												
4	4.06	1.5	16.0	16.125	10.00	4.06	14.0 [†]	5.94	8.50	48	—	8.43	150	100	
6	6.00	1.5	19.5	19.625	12.50	6.00	18.0 [†]	7.91	11.25	—	12	10.43	300	225	
8	8.00	2.0	23.5	23.625	15.00	8.00	21.5 [†]	10.00	15.50	—	18	12.55	550	450	
10	10.00	2.0	26.5	26.625	17.50	10.00	23.5 [†]	12.12	18.50	—	24	14.54	850	650	
12	12.00	3.0	30.0	30.125	20.50	12.00	26.5 [†]	14.50	22.36	—	18	20.14	1,400	1,100	
14	13.25	3.0	32.5	32.625	23.00	13.25	28.5 [†]	14.64	24.00	—	24	21.16	1,650	1,230	
16	15.25	4.0	35.5	35.625	25.50	15.25	30.5 [†]	17.84	26.32	—	18	24.78	2,225	1,770	
18	17.25	4.0	38.5	38.625	28.00	17.25	33.5 [†]	19.25	29.20	—	24	26.19	2,850	2,200	
20	19.25	5.0	41.5	41.750	30.50	19.25	35.5 [†]	22.11	32.27	—	24	30.00	3,750	3,000	
22	21.25	5.0	45.0	45.375	33.00	21.25	38.5 [†]	23.63	36.00	—	24	31.53	4,750	3,950	
24	23.25	5.0	48.5	48.875	36.00	23.25	42.0 [†]	25.05	38.76	—	24	32.95	5,600	4,750	
26	25.00	5.0	51.5	52.000	38.25	25.00	44.5 [†]	26.49	41.75	—	24	34.34	7,100	5,600	
28	27.00	5.0	55.0	55.500	40.75	27.00	47.0 [†]	27.88	44.86	—	30	35.72	8,560	6,500	
30	29.00	5.0	60.0	60.500	43.00	29.00	49.0 [†]	29.51	47.90	—	36	37.37	10,600	8,800	
32	30.75	7.5	65.0	65.630	45.25	30.75	52.0 [†]	34.25	52.25	—	24	44.53	**	10,494	
34	32.75	7.5	70.0	70.625	47.50	32.75	54.5 [†]	35.19	53.64	—	30	45.31	15,400	12,300	
36	34.50	7.5	74.0	74.625	50.00	34.50	56.5 [†]	36.80	56.83	—	30	46.92	18,000	15,500	
40	38.50	7.5	78.0	—	50.00	38.50	65.0 [†]	40.14	65.00	—	42	50.25	25,500	22,250	
42	41.25	7.5	81.0	—	52.00	41.25	66.5 [†]	41.78	68.60	—	42	51.89	28,750	24,750	
48	46.50	9.0	91.0	—	59.50	46.50	76.0 [†]	47.98	77.00	—	—	—	—	—	
Size, mm													Weight, kg		
50	52		Use ASME Class 600 valves (PN 100)												
80	80		Use ASME Class 600 valves (PN 100)												
100	103	38	406	410	254	103	356 [†]	151	216	1,219	—	214	68	45	
150	152	38	495	498	318	152	457 [†]	201	286	—	305	265	136	102	
200	203	51	597	600	381	203	546 [†]	254	394	—	457	319	249	204	
250	254	51	673	676	445	254	597 [†]	308	470	—	610	369	386	295	
300	305	76	762	765	521	305	673 [†]	368	568	—	457	512	635	499	
350	337	76	826	829	584	337	724 [†]	372	610	—	610	537	748	558	
400	387	102	902	905	648	387	775 [†]	453	669	—	457	629	1,009	803	
450	438	102	978	981	711	438	851 [†]	489	742	—	610	665	1,293	998	
500	489	127	1,054	1,060	775	489	902 [†]	562	820	—	610	762	1,701	1,361	
550	540	127	1,143	1,153	838	540	978 [†]	600	914	—	610	801	2,155	1,792	
600	591	127	1,232	1,241	914	591	1,067 [†]	636	985	—	610	837	2,540	2,155	
650	635	127	1,308	1,321	971	635	1,130 [†]	673	1,060	—	610	872	3,221	2,540	
700	686	127	1,397	1,410	1,035	686	1,194 [†]	708	1,139	—	762	907	3,883	2,948	
750	737	127	1,524	1,537	1,092	737	1,245 [†]	750	1,217	—	914	949	4,808	3,992	
800	781	191	1,651	1,667	1,149	781	1,321 [†]	870	1,327	—	610	1,131	**	4,760	
850	832	191	1,778	1,794	1,207	832	1,384 [†]	894	1,362	—	762	1,151	6,985	5,579	
900	876	191	1,880	1,895	1,270	876	1,435 [†]	935	1,443	—	762	1,192	8,165	7,031	
1,000	978	191	1,981	—	1,270	978	1,651 [†]	1,020	1,651	—	1,067	1,276	11,567	10,092	
1,050	1,048	191	2,057	—	1,321	1,048	1,689 [†]	1,061	1,742	—	1,067	1,318	13,041	11,226	
1,200	1,181	229	2,311	—	1,511	1,181	1,930 [†]	1,219	1,956	—	—	—	—	—	

¹Length (A) of a weld x flanged-end valve is one half the sum of length (A) of a weld end and a flange end of the same size and rating.

[†]Short pattern.

⁵Dimensions of 22-in [550-mm] flanges are per MSS-SP-44, and 26-in [650-mm] to 42-in [1,050-mm] flanges are per ASME B16.47 series A.

** For additional information, please contact Cameron engineering team.

ASME Class 400 (PN 64)

Reduced bore

Dimensions

Size, in			Flanged End [†]				Weld End [†] Length	C.L. to Bottom	Body Sphere	Lever Length	Diameter Handwheel for Gear	C.L. to Handwheel C.L.	Approximate Valve Weight, lbm	
Nom. Diameter	Ball Bore	Stem Size	RF Length	RTJ Length	Diameter D1 [§]	Diameter D2							A	C
B			A	A	D1 [§]	D2	A	C	E	L	G	H	Flange	Weld
3	2.06		Use ASME Class 600 valves (PN 100)											
4	3.13	1.0	16.0	16.125	10.00	4.06	12.5 [‡]	5.12	6.75	24	—	7.44	125	87
6	4.06	1.5	19.5	19.625	12.50	6.00	14.0 [‡]	5.94	8.50	48	—	8.43	189	150
8	6.00	1.5	23.5	23.625	15.00	8.00	18.0 [‡]	7.91	11.25	—	12	10.43	424	290
10	8.00	2.0	26.5	26.625	17.50	10.00	21.5 [‡]	10.00	15.50	—	18	12.55	608	525
12	10.00	2.0	30.0	30.125	20.50	12.00	23.5 [‡]	12.12	18.50	—	24	14.54	1,020	840
14	12.00	3.0	32.5	32.625	23.00	13.25	26.5 [‡]	14.50	22.36	—	18	20.14	1,490	1,160
16	13.25	3.0	35.5	35.625	25.25	15.25	28.5 [‡]	14.64	24.00	—	24	21.16	1,910	1,330
18	15.25	4.0	38.5	38.625	28.00	17.25	30.5 [‡]	17.84	36.32	—	18	24.78	2,400	1,920
20	17.25	4.0	41.5	41.750	30.50	19.25	33.5 [‡]	19.25	29.20	—	24	26.19	3,200	2,650
22	19.25	5.0	45.0	45.375	33.00	21.25	35.5 [‡]	22.11	32.27	—	24	30.00	4,250	3,300
24	21.25	5.0	48.5	48.875	36.00	23.25	38.5 [‡]	23.63	36.00	—	24	31.53	5,050	4,300
26	23.25	5.0	51.5	52.000	38.25	25.00	42.0 [‡]	25.05	38.76	—	24	32.95	6,250	5,100
28	25.00	5.0	55.0	55.500	40.75	27.00	44.5 [‡]	26.49	41.75	—	24	34.34	7,750	6,100
30	27.00	5.0	60.0	60.500	43.00	29.00	47.0 [‡]	27.88	44.86	—	30	35.72	9,500	7,600
32	29.00	5.0	65.0	65.625	45.25	32.75	49.0 [‡]	29.51	47.90	—	36	37.37	11,500	9,350
36	32.75	7.5	74.0	74.625	50.00	34.50	54.5 [‡]	35.19	53.64	—	30	45.31	16,000	13,000
42	34.50	7.5	81.0	—	52.00	41.25	56.5 [‡]	36.80	56.83	—	30	46.92	—	—
Size, mm			Use ASME Class 600 valves (PN 100)										Weight, kg	
80	52		Use ASME Class 600 valves (PN 100)											
100	80	25	406	410	254	103	318 [‡]	130	171	610	—	189	57	39
150	103	38	495	498	318	152	356 [‡]	151	216	1,219	—	214	86	68
200	152	38	597	600	381	203	457 [‡]	201	286	—	305	265	192	132
250	203	51	673	676	445	254	546 [‡]	254	394	—	457	319	276	238
300	254	51	762	765	521	305	597 [‡]	308	470	—	610	369	463	381
350	305	76	826	829	584	337	673 [‡]	368	568	—	457	512	676	526
400	337	76	902	905	641	387	724 [‡]	372	610	—	610	537	866	603
450	387	102	978	981	711	438	775 [‡]	453	923	—	457	629	1,089	871
500	438	102	1,054	1,060	775	489	851 [‡]	489	742	—	610	665	1,451	1,202
550	489	127	1,143	1,153	838	540	902 [‡]	562	820	—	610	762	1,928	1,497
600	540	127	1,232	1,241	914	591	978 [‡]	600	914	—	610	801	2,291	1,950
650	591	127	1,308	1,321	972	635	1,067 [‡]	636	985	—	610	837	2,835	2,313
700	635	127	1,397	1,410	1,035	686	1,130 [‡]	673	1,060	—	610	872	3,515	2,767
750	686	127	1,524	1,537	1,092	737	1,194 [‡]	708	1,139	—	762	907	4,309	3,447
800	737	127	1,651	1,667	1,149	832	1,245 [‡]	750	1,217	—	914	949	5,216	4,241
900	832	191	1,880	1,895	1,270	876	1,384 [‡]	894	1,362	—	762	1,151	7,257	5,897
1,050	876	191	2,057	—	1,321	1,048	1,435 [‡]	935	1,443	—	762	1,192	—	—

[†] Length (A) of a weld x flanged-end valve is one half the sum of length (A) of a weld end and a flange end of the same size and rating.

[‡] Short pattern.

[§] Dimensions of 22-in [550-mm] flanges are per MSS-SP-44, and 26-in [650-mm] to 42-in [1,050-mm] flanges are per ASME B16.47 series A.

ASME Class 600 (PN 100)

Full bore

Dimensions														
Size, in			Flanged End [†]				Weld End [‡] Length	C.L. to Bottom	Body Sphere	Lever Length	Diameter Handwheel for Gear	C.L. to Handwheel C.L.	Approximate Valve Weight, lbm	
Nom. Diameter	Ball Bore	Stem Size	RF Length	RTJ Length	Diameter	Diameter							Flange	Weld
B			A	A	D1 [§]	D2	A	C	E	L	G	H		
2	2.06	1	11.5	11.625	6.5	2.06	11.0 [‡]	3.94	5	24	—	6.34	60	45
3	3.13	1	14	14.125	8.25	3.13	12.5 [‡]	5.12	6.75	36	—	7.44	85	75
4	4.06	1.5	17	17.125	10.75	4.06	14.0 [‡]	5.94	8.5	48	—	8.43	165	100
6	6.00	1.5	22	22.125	14	6	18.0 [‡]	7.91	11.25	—	12	10.43	360	225
8	8.00	2	26	26.125	16.5	8	21.5 [‡]	10	15.5	—	18	12.55	650	450
10	10.00	2	31	31.125	20	10	23.5 [‡]	12.12	18.5	—	24	14.54	1,000	650
12	12.00	3	33	33.125	22	12	26.5 [‡]	14.5	22.36	—	18	20.14	1,510	1,100
14	13.25	3	35	35.125	23.75	13.25	28.5 [‡]	14.64	24	—	24	21.16	1,910	1,230
16	15.25	4	39	39.125	27	15.25	30.5 [‡]	17.84	26.32	—	18	24.78	2,400	1,770
18	17.25	4	43	43.125	29.25	17.25	33.5 [‡]	19.25	29.2	—	24	26.19	2,955	2,200
20	19.25	5	47	47.25	32	19.25	35.5 [‡]	22.11	32.27	—	24	30	4,100	3,000
22	21.25	5	51	51.375	34.25	21.25	38.5 [‡]	23.63	36	—	24	31.53	5,400	3,950
24	23.25	5	55	55.375	37	23.25	42.0 [‡]	25.05	38.76	—	30	32.95	6,550	4,750
26	25.00	5	57	57.5	40	25	44.5 [‡]	26.49	41.75	—	36	34.34	7,800	5,600
28	27.00	7.5	61	61.5	42.25	27	47.0 [‡]	30.87	44.86	—	30	40.99	9,500	6,700
30	29.00	7.5	65	65.5	44.5	29	49.0 [‡]	32.53	47.9	—	30	42.65	12,000	9,120
32	30.75	7.5	70	70.630	47.00	30.75	52.0 [‡]	34.25	52.25	—	42	44.50	13,999	10,494
34	32.75	7.5	76	76.625	49	32.75	54.5 [‡]	35.19	53.64	—	42	45.31	16,025	12,300
36	34.5	7.5	82	82.625	51.75	34.5	56.5 [‡]	36.8	56.83	—	42	46.92	19,100	15,500
40	38.5	9	80	—	52	38.5	65.0 [‡]	42.02	65	—	42	55.425	26,770	23,000
42	41.25	9	83	—	55.25	41.25	66.5 [‡]	43.66	68.6	—	42	57.06	30,500	25,500
44	42.75	11	—	—	—	42.75	70.5 [‡]	46.95	71.00	—	—	—	—	—
48	46.50	11	94	—	62.75	46.5	76.0 [‡]	51.18	77.33	—	—	—	—	—
56	55.12	13	—	—	—	55.12	93.7 [‡]	59.10	91.70	—	—	—	—	—
Size, mm													Weight, kg	
50	52	25	292	295	165	52	279 [‡]	100	127	610	—	161	27	20
80	80	25	356	359	210	80	318 [‡]	130	171	914	—	189	39	34
100	103	38	432	435	273	103	356 [‡]	151	216	1,219	—	214	75	45
150	152	38	559	562	356	152	457 [‡]	201	286	—	305	265	163	102
200	203	51	660	664	419	203	546 [‡]	254	394	—	457	319	295	204
250	254	51	787	791	508	254	597 [‡]	308	470	—	610	369	454	295
300	305	76	838	841	559	304	673 [‡]	368	568	—	457	512	685	499
350	337	76	889	892	603	337	724 [‡]	372	610	—	610	537	866	558
400	387	102	991	994	686	387	775 [‡]	453	669	—	457	629	1,089	803
450	438	102	1,092	1,095	743	438	851 [‡]	489	742	—	610	665	1,340	998
500	489	127	1,194	1,200	813	489	902 [‡]	562	820	—	610	762	1,860	1,361
550	540	127	1,295	1,305	870	540	978 [‡]	600	914	—	610	801	2,449	1,792
600	591	127	1,397	1,407	940	591	1,067 [‡]	636	985	—	762	837	2,971	2,155
650	635	127	1,448	1,461	1,016	635	1,130 [‡]	673	1,060	—	914	872	3,538	2,540
700	686	191	1,549	1,562	1,073	686	1,194 [‡]	784	1,139	—	762	1,041	4,309	3,039
750	737	191	1,651	1,664	1,130	737	1,245 [‡]	826	1,217	—	762	1,083	5,443	4,137
800	781	191	1,778	1,794	1,193.8	781	1,321 [‡]	870	1,327	—	1,067	1,130	6,350	4,760
850	832	191	1,930	1,946	1,245	832	1,384 [‡]	894	1,362	—	1,067	1,151	7,269	5,579
900	876	191	2,083	2,099	1,314	876	1,435 [‡]	935	1,443	—	1,067	1,192	8,664	7,031
1,000	978	229	2,032	—	1,321	978	1,651 [‡]	1,067	1,651	—	1,067	1,408	12,143	10,433
1,050	1,048	229	2,108	—	1,403	1,048	1,689 [‡]	1,109	1,742	—	1,067	1,449	13,835	11,567
1,100	1,086	279	—	—	—	1,086	1,791 [‡]	1,192	1,803	—	—	—	—	—
1,200	1,181	279	2,388	—	1,594	1,181	1,930 [‡]	1,300	1,964	—	—	—	—	—
1,400	1,400	330	—	—	—	1,400	2,381 [‡]	1,501	2,328	—	—	—	—	—

[†]Length (A) of a weld x flanged-end valve is one half the sum of length (A) of a weld end and a flange end of the same size and rating.

[‡]Short pattern.

[§]Dimensions of 22-in [550-mm] flanges are per MSS-SP-44, and 26-in [650-mm] to 42-in [1,050-mm] flanges are per ASME B16.47 series A.

ASME Class 600 (PN 100)

Reduced bore

Dimensions														
Size, in			Flanged End [†]				Weld End [†]	C.L. to Bottom	Body Sphere	Lever Length	Diameter Handwheel for Gear	C.L. to Handwheel C.L.	Approximate Valve Weight, lbm	
Nom. Diameter	Ball Bore	Stem Size	RF Length	RTJ Length	Diameter		Length						Flange	Weld
B			A	A	D1 [§]	D2	A	C	E	L	G	H		
3	2.06	1	14	14.125	8.25	3.13	11.0 [†]	3.94	5	24	—	6.34	80	50
4	3.13	1	17	17.125	10.75	4.06	12.5 [†]	5.12	6.75	36	—	7.44	150	87
6	4.06	1.5	22	22.125	14	6	14.0 [†]	5.94	8.5	48	—	8.43	250	150
8	6.00	1.5	26	26.125	16.5	8	18.0 [†]	7.91	11.25	—	12	10.43	470	290
10	8.00	2	31	31.125	20	10	21.5 [†]	10	15.5	—	18	12.55	850	525
12	10.00	2	33	33.125	22	12	23.5 [†]	12.12	18.5	—	24	14.54	1,150	840
14	12.00	3	35	35.125	23.75	13.25	26.5 [†]	14.5	22.36	—	18	20.14	1,640	1,160
16	13.25	3	39	39.125	27	15.25	28.5 [†]	14.64	24	—	24	21.16	2,225	1,330
18	15.25	4	43	43.125	29.25	17.25	30.5 [†]	17.84	26.32	—	18	24.78	2,600	1,920
20	17.25	4	47	47.25	32	19.25	33.5 [†]	19.25	29.2	—	24	26.19	3,500	2,650
22	19.25	5	51	51.375	34.25	21.25	35.5 [†]	22.11	32.27	—	24	30	4,450	3,300
24	21.25	5	55	55.375	37	23.25	38.5 [†]	23.63	36	—	24	31.53	5,750	4,300
26	23.25	5	57	57.5	40	25	42.0 [†]	25.05	38.76	—	30	32.95	7,000	5,100
28	25.00	5	61	61.5	42.25	27	44.5 [†]	26.49	41.75	—	36	34.34	8,600	6,300
30	27.00	7.5	65	65.5	44.5	29	47.0 [†]	30.87	44.86	—	30	40.99	10,100	7,800
32	29.00	7.5	70.00	70.630	47.00	30.75	49.0 [†]	32.53	47.90	—	30	42.65	12,800	9,350
34	29.00	7.5	76.00	76.625	49.00	32.75	49.0 [†]	32.53	47.90	—	30	42.65	15,200	11,200
36	32.75	7.5	82	82.625	51.75	34.5	54.5 [†]	35.19	53.64	—	42	45.31	17,600	13,000
42	34.50	7.5	83	—	55.25	41.25	56.5 [†]	36.8	56.83	—	42	46.92	—	—
44	38.50	9	—	—	—	42.75	65.0 [†]	42.02	65.00	—	—	—	—	—
56	46.50	11	—	—	—	55.10	76.0 [†]	51.18	77.32	—	—	—	—	—
Size, mm													Weight, kg	
80	52	25	356	359	210	80	279 [†]	100	127	610	—	161	36	23
100	80	25	432	435	273	103	318 [†]	130	171	914	—	189	68	39
150	103	38	559	562	356	152	356 [†]	151	216	1,219	—	214	113	68
200	152	38	660	664	419	203	457 [†]	201	286	—	305	265	213	132
250	203	51	787	791	508	254	546 [†]	254	394	—	457	319	386	238
300	254	51	838	841	559	305	597 [†]	308	470	—	610	369	522	381
350	305	76	889	892	603	337	673 [†]	368	568	—	457	512	744	526
400	337	76	991	994	686	387	724 [†]	372	610	—	610	537	1,009	603
450	387	102	1,092	1,095	743	438	775 [†]	453	669	—	457	629	1,179	871
500	438	102	1,194	1,200	813	489	851 [†]	489	742	—	610	665	1,588	1,202
550	489	127	1,295	1,305	870	540	902 [†]	562	820	—	610	762	2,018	1,497
600	540	127	1,397	1,407	940	591	978 [†]	600	914	—	610	801	2,608	1,950
650	591	127	1,448	1,461	1,016	635	1,067 [†]	636	985	—	762	837	3,175	2,313
700	635	127	1,549	1,562	1,073	686	1,130 [†]	673	1,060	—	914	872	3,901	2,858
750	686	191	1,651	1,664	1,130	737	1,194 [†]	784	1,139	—	762	1,041	4,581	3,538
800	737	191	1,778	1,794	1,194	781	1,245 [†]	826	1,217	—	762	1,083	5,800	4,250
850	737	191	1,930	1,946	1,245	832	1,245 [†]	826	1,217	—	762	1,083	6,900	5,100
900	832	191	2,083	2,099	1,314	876	1,384 [†]	894	1,362	—	1,067	1,151	7,983	5,897
1,100	978	229	—	—	—	1,086	1,651 [†]	1,067	1,651	—	—	—	—	—
1,400	1,181	279	—	—	—	1,400	1,930 [†]	1,300	1,964	—	—	—	—	—

[†]Length (A) of a weld x flanged-end valve is one half the sum of length (A) of a weld end and a flange end of the same size and rating.

[‡]Short pattern.

[§]Dimensions of 22-in [550-mm] flanges are per MSS-SP-44, and 26-in [650-mm] to 42-in [1,050-mm] flanges are per ASME B16.47 series A.

ASME Class 900 (PN 150)

Full bore

Dimensions															
Size, in			Flanged End [†]				Weld End [†] Length	C.L. to Bottom	Body Sphere	Lever Length	Diameter Handwheel for Gear	C.L. to Handwheel C.L.	Approximate Valve Weight, lbm		
Nom. Diameter	Ball Bore	Stem Size	RF Length	RTJ Length	Diameter D1 [‡]	Diameter D2							A	C	E
			Use 1,500 Class valves (PN 250)												
2	2.06														
3	3.13	1.5	15.0	15.125	9.50	3.13	13.5 [‡]	4.88	7.00	36	—	7.44	140	120	
4	4.06	2.0	18.0	18.125	11.50	4.06	15.0 [‡]	6.77	9.25	—	12	9.76	250	190	
6	6.00	2.0	24.0	24.125	15.00	6.00	20.0 [‡]	8.39	12.50	—	18	10.86	525	410	
8	8.00	2.0	29.0	29.125	18.50	8.00	23.5 [‡]	10.00	15.50	—	24	12.55	1,210	590	
10	10.00	3.0	33.0	33.125	21.50	10.00	25.5 [‡]	12.88	18.50	—	18	18.49	1,325	1,010	
12	12.00	3.0	38.0	38.125	24.00	12.00	29.5 [‡]	14.50	22.36	—	24	20.14	2,250	1,350	
14	12.75	5.0	40.5	40.875	25.25	12.75	31.5 [‡]	17.40	24.50	—	24	25.30	3,250	2,155	
16	14.75	5.0	44.5	44.875	27.75	14.75	33.5 [‡]	19.02	27.25	—	24	26.92	4,000	2,450	
18	16.75	5.0	48.0	48.500	31.00	16.75	36.5 [‡]	20.62	30.07	—	24	28.51	5,300	3,950	
20	18.625	7.5	52.0	52.500	33.75	18.625	38.5 [‡]	24.22	33.88	—	24	35.23	7,100	5,250	
22	20.625	7.5	**	**	**	20.625	41.5 [‡]	25.71	36.50	—	24	36.72	**	5,099	
24	22.50	7.5	61.0	61.750	41.00	22.50	45.0 [‡]	28.07	39.95	—	30	38.18	10,500	6,450	
26	25.00	7.5	65.0	65.880	42.75	25.00	**	33.63	42.55	—	36	39.59	9,778	**	
28	27.00	7.5	**	70.840	46.00	27.00	50.0 [‡]	30.87	47.00	—	36	40.99	**	8,988	
30	29.00	7.5	75.0	75.875	48.50	29.00	52.0 [‡]	32.53	49.88	—	42	42.65	17,500	11,500	
32	30.75	9.0	**	**	51.75	30.75	55.0 [‡]	36.29	53.25	—	40	49.43	**	**	
36	34.50	9.0	90.0	91.125	57.50	34.50	59.5 [‡]	38.64	58.25	—	—	52.03	25,600	17,500	
Size, mm													Weight, kg		
50	52		Use 1,500 Class valves (PN 250)												
30	80	38	381	384	241	80	343 [‡]	124	178	914	—	189	64	54	
100	103	51	457	460	292	103	381 [‡]	172	235	—	305	248	113	86	
150	152	51	610	613	381	152	508 [‡]	213	318	—	457	276	238	186	
200	203	51	737	740	410	203	597 [‡]	254	394	—	610	319	549	268	
250	254	76	838	841	546	254	648 [‡]	327	470	—	457	470	601	458	
300	305	76	965	968	610	305	749 [‡]	368	568	—	610	512	1,021	612	
350	324	127	1,029	1,038	641	324	800 [‡]	442	622	—	610	643	1,474	977	
400	375	127	1,130	1,140	705	375	851 [‡]	483	692	—	610	684	1,814	1,111	
450	425	127	1,219	1,232	787	425	927 [‡]	524	764	—	610	724	2,404	1,792	
500	473	191	1,321	1,334	857	473	978 [‡]	615	861	—	610	895	3,221	2,381	
550	524	191	**	**	**	524	1,054 [‡]	653	927	—	610	933	**	2,313	
600	572	191	1,549	1,568	1,041	572	1,143 [‡]	713	1,015	—	762	970	4,763	2,926	
650	635	191	1,651	1,673	1,086	635	**	854	1,081	—	914	1,006	4,435	**	
700	686	191	**	1,799	1,168	686	1,270 [‡]	784	1,194	—	914	1,041	**	4,077	
750	737	191	1,905	1,927	1,232	737	1,321 [‡]	826	1,267	—	1,067	1,083	7,938	5,216	
800	781	229	**	**	1,314	781	1,397 [‡]	922	1,353	—	1,016	1,256	**	**	
900	876	229	2,286	2,315	1,461	876	1,511 [‡]	981	1,480	—	—	1,322	11,612	7,938	

[†]Length (A) of a weld x flanged-end valve is one half the sum of length (A) of a weld end and a flange end of the same size and rating.

[‡]Short pattern.

[‡]Dimensions of 22-in [550-mm] flanges are per MSS-SP-44, and 26-in [650-mm] to 42-in [1,050-mm] flanges are per ASME B16.47 series A.

** For additional information, please contact Cameron engineering team.

ASME Class 900 (PN 150)

Reduced bore

Dimensions

Size, in			Flanged End [†]				Weld End [†] Length	C.L. to Bottom	Body Sphere	Lever Length	Diameter Handwheel for Gear	C.L. to Handwheel C.L.	Approximate Valve Weight, lbm	
Nom. Diameter	Ball Bore	Stem Size	RF Length	RTJ Length	Diameter D1 [§]	Diameter D2							A	C
B			A	A	D1 [§]	D2	A	C	E	L	G	H	Flange	Weld
3	2.06	1.0	15.0	15.125	9.50	3.13	11.0 [†]	3.94	5.00	24	–	6.34	120	70
4	3.13	1.5	18.0	18.125	11.50	4.06	13.5 [†]	4.88	7.00	36	–	7.44	190	150
6	4.06	2.0	24.0	24.125	15.00	6.00	15.0 [†]	6.77	9.25	–	12	9.76	400	260
8	6.00	2.0	29.0	29.125	18.50	8.00	20.0 [†]	8.39	12.50	–	18	10.86	850	650
10	8.00	2.0	33.0	33.125	21.50	10.00	23.5 [†]	10.00	15.50	–	24	12.55	1,290	725
12	10.00	3.0	38.0	38.125	24.00	12.00	25.5 [†]	12.88	18.50	–	18	18.49	1,700	1,110
14	12.00	3.0	40.5	40.875	25.25	12.75	29.5 [†]	14.50	22.36	–	24	20.14	2,750	1,680
16	12.75	5.0	44.5	44.875	27.75	14.75	31.5 [†]	17.40	24.50	–	24	25.30	3,650	2,300
Size, mm													Weight, kg	
80	52	25	381	384	241	80	279 [†]	100	127	610	–	161	54	32
100	80	38	457	460	292	103	343 [†]	124	178	914	–	189	86	68
150	103	51	610	613	381	152	381 [†]	172	235	–	305	248	181	118
200	152	51	737	740	470	203	508 [†]	213	318	–	457	276	386	295
250	203	51	838	841	546	254	597 [†]	254	394	–	610	319	585	329
300	254	76	965	968	610	305	648 [†]	327	470	–	457	470	771	503
350	305	76	1,029	1,038	641	324	749 [†]	368	568	–	610	512	1,247	762
400	324	127	1,130	1,140	705	375	800 [†]	442	622	–	610	643	1,656	1,043

[†] Length (A) of a weld × flanged-end valve is one half the sum of length (A) of a weld end and a flange end of the same size and rating.

[‡] Short pattern.

[§] Dimensions of 22-in [550-mm] flanges are per MSS-SP-44, and 26-in [650-mm] to 42-in [1,050-mm] flanges are per ASME B16.47 series A.

Note: Venturi opening or other reduced-bore valves are available upon request.

ASME Class 1500 (PN 250)

Full bore

Dimensions														
Size, in			Flanged End ¹				Weld End ² Length	C.L. to Bottom	Body Sphere	Lever Length	Diameter Handwheel for Gear	C.L. to Handwheel C.L.	Approximate Valve Weight, lbm	
Nom. Diameter	Ball Bore	Stem Size	RF Length	RTJ Length	Diameter D1	Diameter D2							Flange	Weld
	B		A	A	D1	D2	A	C	E	L	G	H		
2	2.06	1.0	14.50	14.625	8.50	2.06	11.0 ²	3.94	5.00	36	—	6.34	100	45
3	3.13	1.5	18.50	18.625	10.50	3.13	13.5 ²	4.88	7.00	—	12	7.44	180	120
4	4.06	2.0	21.50	21.625	12.25	4.06	15.0 ²	6.77	9.25	—	12	9.76	300	190
6	6.00	2.0	27.75	28.000	15.50	6.00	20.0 ²	8.39	12.50	—	18	10.86	715	410
8	8.00	3.0	32.75	33.125	19.00	8.00	23.5 ²	10.95	16.38	—	18	16.89	1,550	1,075
10	10.00	4.0	39.00	39.375	23.00	10.00	25.5 ²	15.15	19.50	—	18	19.96	2,000	1,575
12	12.00	4.0	44.50	45.125	26.50	12.00	29.5 ²	17.31	23.38	—	24	21.80	3,250	1,825
14	12.75	5.0	49.50	50.250	29.50	12.75	31.5 ²	17.40	26.00	—	24	25.30	4,200	2,550
16	14.75	5.0	54.50	55.375	32.50	14.75	33.5 ²	19.02	29.25	—	30	26.92	5,400	2,950
18	16.75	7.5	60.50	61.375	36.00	16.75	36.5 ²	22.69	31.57	—	30	33.71	6,350	5,125
20	18.625	7.5	65.50	66.375	38.75	18.625	38.5 ²	24.22	34.72	—	30	35.23	9,260	6,025
24	22.50	7.5	76.50	77.625	46.00	22.50	45.0 ²	28.07	42.16	—	48	38.18	16,250	9,400
Size, mm													Weight, kg	
50	52	25	368	371	216	52	279 ²	100	127	914	—	161	45	20
80	80	38	470	473	267	80	343 ²	124	178	—	305	189	82	54
100	103	51	546	549	311	103	381 ²	172	235	—	305	248	136	86
150	152	51	705	711	394	152	508 ²	213	318	—	457	276	324	186
200	203	76	832	841	483	203	597 ²	278	416	—	457	429	703	488
250	254	102	991	1,000	584	254	648 ²	385	495	—	457	507	907	714
300	305	102	1,130	1,146	673	305	749 ²	440	594	—	610	554	1,474	828
350	324	127	1,257	1,276	749	324	800 ²	442	660	—	610	643	1,905	1,157
400	375	127	1,384	1,407	826	375	851 ²	483	743	—	762	684	2,449	1,338
450	425	191	1,537	1,559	914	425	927 ²	576	802	—	762	856	2,880	2,325
500	473	191	1,664	1,686	984	473	978 ²	615	882	—	762	895	4,200	2,733
600	572	191	1,943	1,972	1,168	572	1,143 ²	713	1,071	—	1,219	970	7,371	4,264

¹Length (A) of a weld x flanged-end valve is one half the sum of length (A) of a weld end and a flange end of the same size and rating.

²Short pattern.

ASME Class 1500 (PN 250)

Reduced bore

Dimensions														
Size, in			Flanged End ¹				Weld End ¹ Length	C.L. to Bottom	Body Sphere	Lever Length	Diameter Handwheel for Gear	C.L. to Handwheel C.L.	Approximate Valve Weight, lbm	
Nom. Diameter	Ball Bore	Stem Size	RF Length	RTJ Length	Diameter D1	Diameter D2							A	C
B			A	A	D1	D2	A	C	E	L	G	H		
3	2.06	1.0	18.50	18.625	10.50	3.13	11.0 ¹	3.94	5.00	36	–	6.34	150	70
4	3.13	1.5	21.50	21.625	12.25	4.06	13.5 ¹	4.88	7.00	–	12	7.44	240	150
6	4.06	2.0	27.75	28.000	15.50	6.00	15.0 ¹	6.77	9.25	–	12	9.76	550	260
8	6.00	2.0	32.75	33.125	19.00	8.00	20.0 ¹	8.39	12.50	–	18	10.86	1,025	650
10	8.00	3.0	39.00	39.375	23.00	10.00	23.5 ¹	10.95	16.38	–	18	16.89	1,725	1,200
12	10.00	4.0	44.50	45.125	26.50	12.00	25.5 ¹	15.15	19.50	–	18	19.96	2,810	1,650
14	12.00	4.0	49.50	50.250	29.50	12.75	29.5 ¹	17.31	23.38	–	24	21.80	3,750	2,100
16	12.75	5.0	54.50	55.375	32.50	14.75	31.5 ¹	17.40	26.00	–	24	25.30	5,150	2,725
Size, mm													Weight, kg	
80	52	25	470	473	267	80	279 ¹	100	127	914	–	161	68	32
100	90	38	546	549	311	103	343 ¹	124	178	–	305	189	109	68
150	103	51	705	711	394	152	381 ¹	172	235	–	305	248	249	118
200	152	51	832	841	483	203	508 ¹	213	318	–	457	276	465	295
250	203	76	991	1,000	584	254	597 ¹	278	416	–	457	429	782	544
300	254	102	1,130	1,146	673	305	648 ¹	385	495	–	457	507	1,275	748
350	305	102	1,257	1,276	749	324	749 ¹	440	594	–	610	554	1,701	953
400	324	127	1,384	1,407	826	375	800 ¹	442	660	–	610	643	2,336	1,236

¹Length (A) of a weld x flanged-end valve is one half the sum of length (A) of a weld end and a flange end of the same size and rating.

²Short pattern.

Note: Venturi opening or other reduced-bore valves are available upon request.

ASME Class 2500 (PN 420)

Full and reduced bore

Dimensions															
Size, in			Flanged End ¹				Weld End ² Length	C.L. to Bottom	Body Sphere	Lever Length	Diameter Handwheel for Gear	C.L. to Handwheel C.L.	Approximate Valve Weight, lbm		
Nom. Diameter	Ball Bore	Stem Size	RF Length	RTJ Length	Diameter D1	Diameter D2							A	C	E
			B	A	A	D1	D2	A	C	E	L	G	H		
Full Opening															
2	2.06	1.0	17.75	17.875	9.25	2.06	15 [‡]	4.53	5.43	48	–	7.25	114	94	
3	3.13	1.5	22.75	23.000	12.00	3.13	18 [‡]	5.67	7.50	–	12	8.94	236	187	
4	4.06	2.0	26.50	26.875	14.00	4.06	20 [‡]	7.24	9.75	–	18	11.70	471	382	
6	6.00	3.0	36.00	36.500	19.00	6.00	24 [‡]	9.76	13.50	–	24	13.13	943	737	
8	7.125	4.0	40.50	40.875	21.75	7.125	28 [‡]	12.84	18.11	–	24	17.88	2,094	1,676	
10	8.875	4.0	50.00	50.875	26.50	8.875	33 [‡]	14.84	20.87	–	24	20.00	2,922	2,166	
12	10.50	5.0	56.00	56.875	30.00	10.50	36 [‡]	16.65	24.50	–	30	24.75	4,506	3,258	
Reduced Opening															
3	2.06	1.0	22.75	23.000	12.00	3.13	15 [‡]	4.53	5.43	48	–	7.25	156	129	
4	3.13	1.5	26.50	26.875	14.00	4.06	18 [‡]	5.67	7.50	–	12	8.94	286	247	
6	4.06	2.0	36.00	36.500	19.00	6.00	20 [‡]	7.24	9.75	–	18	11.70	638	513	
8	6.00	3.0	40.50	40.875	21.75	7.125	24 [‡]	9.76	13.50	–	24	13.13	1,297	1,017	
10	7.13	4.0	50.00	50.875	26.50	8.875	28 [‡]	12.84	18.11	–	24	17.88	2,518	1,916	
12	8.875	4.0	56.00	56.875	30.00	10.50	33 [‡]	14.875	20.87	–	24	20.00	3,566	2,657	
Size, mm															
Full Opening															
50	52	25	451	454	235	52	381 [‡]	115	138	1,219	–	184	52	43	
80	80	38	578	584	305	80	457 [‡]	144	191	–	305	227	107	85	
100	103	51	673	683	356	103	508 [‡]	184	248	–	457	297	214	173	
150	152	76	914	927	483	152	610 [‡]	248	343	–	610	334	428	334	
200	181	102	1,029	1,038	552.5	181	711 [‡]	326	460	–	610	454	950	760	
250	225	102	1,270	1,292	673	225	838 [‡]	378	530	–	610	508	1,325	983	
300	267	127	1,422	1,445	762	267	914 [‡]	423	622	–	762	629	2,044	1,478	
Reduced Opening															
80	42	25	578	584	305	80	381 [‡]	115	138	1,219	–	184	71	59	
100	80	38	673	683	356	103	457 [‡]	144	191	–	305	227	130	98	
150	103	51	914	927	483	152	508 [‡]	184	248	–	457	297	289	233	
200	152	76	1,029	1,038	553	181	610 [‡]	248	343	–	610	334	588	461	
250	181	102	1,270	1,292	673	225	711 [‡]	326	460	–	610	454	1,142	869	
300	225	102	1,422	1,445	762	267	838 [‡]	377	530	–	610	508	1,618	1,205	

¹Length (A) of a weld x flanged-end valve is one half the sum of length (A) of a weld end and a flange end of the same size and rating.

[‡]Short pattern.

API Flanged 2,000-, 3,000-, and 5,000-psi Working Pressure (WP)

Full bore

Dimensions											
Size, in			Flanged End			C.L. to Bottom	Body Sphere	Lever Length	Diameter Handwheel for Gear	Data for Valve with Operator Normally Furnished	
Nom. Diameter	Ball Bore B	Stem Size	Length A	Diameter D1	Diameter D2					C	E
2,000-psi WP: 4,000-psi Test											
2	2.06	1.0	11.625	6.50	2.06	3.94	5.00	36	–	6.34	44
3	3.13	1.0	14.124	8.25	3.13	5.12	6.75	36	–	7.44	85
4	4.06	1.5	17.125	10.75	4.06	5.94	8.50	36	–	8.43	165
7	6.00	2.0	22.125	14.00	6.00	7.91	11.50	–	24	10.29	445
3,000-psi WP: 6,000-psi Test											
2	2.06	1.0	14.625	8.50	2.06	3.94	5.00	36	–	6.34	90
3	3.13	1.5	15.125	9.50	3.13	4.88	7.00	36	–	7.44	130
4	4.06	2.0	18.125	11.50	4.06	6.77	9.25	36	–	9.76	255
7	6.00	2.0	24.125	15.00	6.00	8.39	12.50	–	30	10.92	675
5,000-psi WP: 10,000-psi Test											
2	2.06	2.0	14.625	8.50	2.06	3.94	5.00	36	–	6.34	95
3	3.13	1.5	18.625	10.50	3.13	4.88	7.00	36	–	7.44	189
4	4.06	2.0	21.625	12.25	4.06	6.77	9.25	–	24	9.30	361
7	6.00	3.0	28.000	15.50	6.00	8.39	13.50	–	24	13.13	805
Size, mm											Weight, kg
13.8-MPa WP: 27.6-MPa Test											
50	52.3	25.4	295	165	52	100	127	914	–	161	20
80	79.5	25.4	359	210	80	130	171	914	–	189	39
100	103.1	38.1	435	274	103	151	216	914	–	214	75
180	152.4	50.8	562	356	152	201	292	–	610	261	202
20.7-MPa WP: 41.4-MPa Test											
50	52.3	25.4	371	216	52	100	127	914	–	161	41
80	79.5	38.1	384	241	80	124	178	914	–	189	59
100	103.1	50.8	460	292	103	172	235	914	–	248	116
180	152.4	50.8	613	381	152	213	318	–	762	277	306
34.5-MPa WP: 70.0-MPa Test											
50	52.3	25.4	371	216	52	100	127	914	–	161	43
80	79.5	38.1	473	267	80	124	178	914	–	189	86
100	103.1	50.8	549	311	103	172	235	914	–	236	164
180	152.4	76.2	711	394	152	213	343	–	610	334	365

API Flanged 2,000-, 3,000-, and 5,000-psi WP

Reduced bore

Dimensions											
Size, in			Flanged End			C.L. to Bottom	Body Sphere	Lever Length	Diameter Handwheel for Gear	Data for Valve with Operator Normally Furnished	
Nom. Diameter	Ball Bore B	Stem Size	Length A	Diameter D1	Diameter D2					C	E
2,000-psi WP: 4,000-psi Test											
3.13	2.06	1.0	14.125	8.25	3.13	3.94	5.00	36	–	6.34	80
4.06	3.13	1.0	17.125	10.75	4.06	5.12	6.75	36	–	7.44	140
7.06	4.06	1.5	22.125	14.00	6.00	5.94	8.50	36	–	8.43	230
3,000-psi WP: 6,000-psi Test											
3.13	2.06	1.0	15.125	9.50	3.13	3.94	5.00	36	–	6.34	105
4.06	3.13	1.5	18.125	11.50	4.06	4.88	7.00	36	–	7.44	197
7.06	4.06	2.0	24.125	15.00	6.00	6.77	9.25	36	–	9.76	345
5,000-psi WP: 10,000-psi Test											
3.13	2.06	1.0	18.625	10.50	3.13	3.94	5.00	36	–	6.34	130
4.06	3.13	1.5	21.625	12.25	4.06	4.88	7.00	36	–	7.44	230
7.06	4.06	2.0	28.000	15.50	6.00	6.77	9.25	–	24	9.30	490
Size, mm											Weight, kg
13.8-MPa WP: 27.6-MPa Test											
79.5	52.3	25.4	359	210	80	100	127	914	–	161	36
103.1	79.5	25.4	435	273	103	130	171	914	–	189	64
179.3	103.1	38.1	562	356	152	151	216	914	–	214	104
20.7-MPa WP: 41.4-MPa Test											
79.5	52.3	25.4	384	241	80	100	127	914	–	161	48
103.1	79.5	38.1	460	292	103	124	178	914	–	189	89
179.4	103.1	50.8	613	381	152	172	235	914	–	248	156
34.5-MPa WP: 70.0-MPa Test											
79.5	52.3	25.4	473	267	80	100	127	914	–	161	59
103.1	79.5	38.1	549	311	103	124	178	914	–	189	104
179.3	103.1	50.8	711	394	152	172	235	–	610	236	222

Dimensional Data

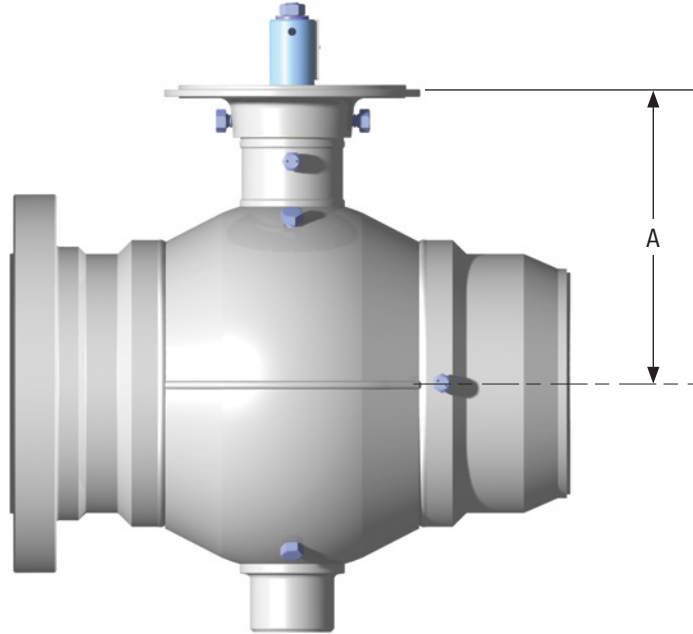

Dimensions Centerline to Mounting Flanged

Bore Size,
in [mm]

Dimension A
ASME Pressure Class

	150	300	400	600	900	1500	2500
	PN 20	PN 50	PN 64	PN 100	PN 150	PN 250	PN 420
2 [50]	4.06 [103]	4.06 [103]	4.06 [103]	4.06 [103]	4.06 [103]	4.06 [103]	4.68 [119]
3 [80]	5.08 [129]	5.08 [129]	5.08 [129]	5.08 [129]	4.76 [121]	4.76 [121]	5.71 [145]
4 [100]	5.79 [147]	5.79 [147]	5.79 [147]	5.79 [147]	6.61 [168]	6.61 [168]	6.89 [175]
6 [150]	7.64 [194]	7.64 [194]	7.64 [194]	7.64 [194]	8.23 [209]	8.23 [209]	12.52 [318]
8 [200]	9.92 [252]	9.92 [252]	9.92 [252]	9.92 [252]	9.92 [252]	13.45 [342]	15.39 [391]
10 [250]	11.91 [303]	11.91 [303]	11.91 [303]	11.91 [303]	15.05 [382]	15.96 [405]	18.07 [459]
12 [300]	16.70 [424]	16.70 [424]	16.70 [424]	16.70 [424]	16.70 [424]	17.80 [452]	19.61 [498]
14 [350]	17.72 [450]	17.72 [450]	17.72 [450]	17.72 [450]	20.55 [522]	20.55 [522]	–
16 [400]	19.08 [485]	19.08 [485]	20.78 [528]	20.78 [528]	22.17 [563]	22.17 [563]	–
18 [450]	22.19 [564]	22.19 [564]	22.19 [564]	22.19 [564]	23.76 [604]	27.71 [704]	–
20 [500]	23.75 [603]	23.75 [603]	25.25 [641]	25.25 [641]	29.23 [742]	29.23 [742]	–
22 [550]	25.22 [641]	25.22 [641]	26.78 [680]	26.78 [680]	30.72 [780]	–	–
24 [600]	26.63 [676]	26.63 [676]	28.20 [716]	28.20 [716]	32.18 [817]	32.18 [817]	–
26 [650]	29.59 [752]	29.59 [752]	29.59 [752]	29.59 [752]	33.59 [853]	–	–
28 [700]	30.97 [787]	30.97 [787]	30.97 [787]	34.99 [889]	34.99 [889]	–	–
30 [750]	32.62 [829]	32.62 [829]	32.62 [829]	36.65 [931]	36.65 [931]	–	–
32 [800]	34.25 [870]	34.25 [870]	38.53 [979]	38.53 [979]	42.05 [1,068]	–	–
34 [850]	35.26 [896]	35.26 [896]	39.31 [998]	39.31 [998]	–	–	–
36 [900]	36.85 [936]	40.92 [1,039]	40.92 [1,039]	40.92 [1,039]	44.65 [1,134]	–	–
40 [1,000]	44.25 [1,124]	44.25 [1,124]	44.25 [1,124]	48.05 [1,220]	–	–	–
42 [1,050]	45.89 [1,166]	45.89 [1,166]	45.89 [1,166]	49.69 [1,262]	–	–	–
48 [1,200]	50.04 [1,271]	50.04 [1,271]	54.02 [1,372]	56.50 [1,435]	–	–	–

The dimensions on this page, combined with the top works dimensions on the following two pages, provide the information required to determine the overall dimensions of a CAMERON T30 Series fully welded ball valve when an actuator is installed.

For additional dimensional information on CAMERON T30 Series fully welded ball valves, contact your sales representative.

Top Works Dimensions

Square nut and adapter flange (BX-1220)

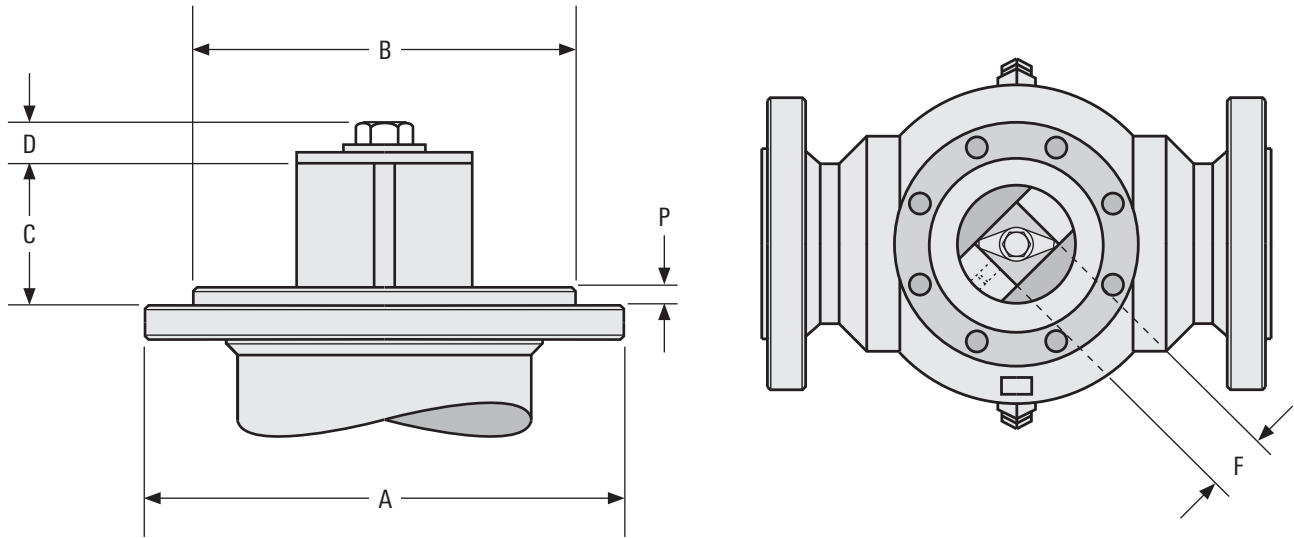

Mounting Dimensions

Dash Number	-1	-2	-3
Valve Stem Size, in	1.00	1.50	2.0
A Flange diameter	6.50	6.50	8.75
B Boss diameter	4.747	4.747	6.997
C Height of nut	1.94	2.12	2.62
D Bolt size	0.44	0.54	0.66
F Width of nut	1.50	2.00	2.50
H Number of holes	8	8	16
J Diameter bolt circle	5.75	5.75	8.00
P Boss height	0.328	0.328	0.328
Flange bolt size	3/8 to 16 NC-2	3/8 to 16 NC-2	3/8 to 16 NC-2
Bolt torque, lbf.ft	30	30	30
Dash Number	-1	-2	-3
Valve Stem Size, mm	25.40	38.10	50.80
A Flange diameter	165.10	165.10	222.25
B Boss diameter	120.57	120.57	177.72
C Height of nut	49.28	53.85	66.55
D Bolt size	11.18	13.72	16.76
F Width of nut	38.10	50.8	63.50
H Number of holes	8	8	16
J Diameter bolt circle	146.05	146.05	203.20
P Boss height	8.33	8.33	8.33
Flange bolt size	3/8 to 16 NC-2	3/8 to 16 NC-2	3/8 to 16 NC-2
Bolt torque, N.m	40.68	40.68	40.68

Note: -1 and -2 bolt holes straddle centerline. -3 bolt holes are on centerline.

Top Works Dimensions

Keyed shaft and adapter flange (BX-1221)

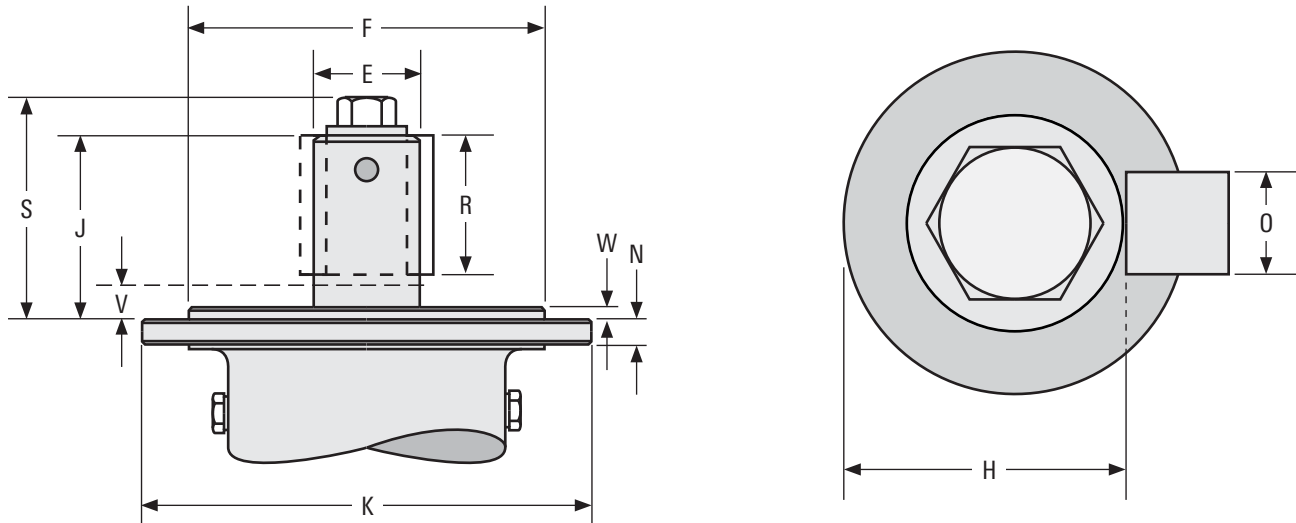

Mounting Dimensions

Dash Number	-4	-5	-6	-7	-8	-9	-10	-11
Valve Stem Size, in	3.00	4.00	5.00	7.50	9.00	11.00	13.00	15.00
A Number of holes	16	16	24	24	24	28	28	32
C Diameter bolt circle	10.375	17.25	18.375	24.00	31.00	27.50	27.50	36.00
E Max. shaft diameter	2.745	3.245	4.495	5.495	6.245	8.995	8.995	—
F Boss diameter	9.122	16.246	17.121	21.746	28.308	25.496	25.496	33.496
H Key seat	2.402	2.831	3.786	4.803	5.409	7.887	6.774	—
J Height of nut	4.75	5.310	6.25	8.50	9.13	13.31	13.31	19.25
K Flange diameter	11.50	18.25	19.380	25.75	32.75	30.00	30.00	39.00
N Flange thickness	0.63	0.63	0.63	1.00	1.00	1.25	1.25	1.50
Q Key width	0.625	0.75	1.25	1.25	1.50	2.00	2.00	2.25
R Key length	3.75	4.310	5.250	7.50	8.13	12.00	12.00	17.50
S Overall height	6.120	7.00	8.120	11.00	11.75	16.12	15.84	21.50
V Adapter flange thickness (max.)	1.00	1.00	1.00	1.00	1.00	1.25	1.25	1.50
W Boss height	0.328	0.328	0.328	0.328	0.328	0.328	0.328	0.328
Flange bolt size	½ to 13 NC-2	½ to 13 NC-2	½ to 13 NC-2	¾ to 9 NC-2	¾ to 9 NC-2	1¼ to 8 NC-2	1¼ to 8 NC-2	1¼ to 8 NC-2
Bolt torque, lbf.ft	60	60	63	330	330	1,000	1,000	1,600
Dash Number	-4	-5	-6	-7	-8	-9	-10	-11
Valve Stem Size, mm	76.20	101.60	127.00	190.50	228.60	279.40	330.20	381.00
A Number of holes	16	16	24	24	24	28	28	32
C Diameter bolt circle	263.53	438.15	466.73	609.60	787.40	698.50	698.50	914.40
E Max. shaft diameter	69.73	82.43	114.18	139.58	158.63	228.48	228.48	—
F Boss diameter	231.69	412.64	434.87	552.34	719.02	647.59	647.59	850.79
H Key seat	61.01	71.91	96.16	122.00	137.38	200.32	172.05	—
J Height of nut	120.65	134.88	158.75	215.90	231.91	338.03	338.03	488.95
K Flange diameter	292.10	463.55	492.26	654.05	831.85	762.00	763.00	990.60
N Flange thickness	16.00	16.00	16.00	25.40	25.40	31.75	31.75	38.10
Q Key width	15.88	19.05	31.75	31.75	38.10	50.80	50.80	57.15
R Key length	95.25	109.48	133.35	190.50	206.51	304.80	304.80	444.50
S Overall height	155.45	177.80	206.25	279.40	298.45	409.45	402.34	546.10
V Adapter flange thickness (max.)	25.40	25.40	25.40	25.40	25.40	31.75	31.75	38.10
W Boss height	8.33	8.33	8.33	8.33	8.33	8.33	8.33	8.33
Flange bolt size	½ to 13 NC-2	½ to 13 NC-2	½ to 13 NC-2	¾ to 9 NC-2	¾ to 9 NC-2	1¼ to 8 NC-2	1¼ to 8 NC-2	1¼ to 8 NC-2
Bolt torque, N.m	81	81	85	447	447	1,356	1,356	2,169

Note: -7 through -11 bolt holes straddle centerline. -4 through -6 holes are on centerline.

Top Works Dimensions

Manual gear dimensions for DYNATORQUE accessories gear operators

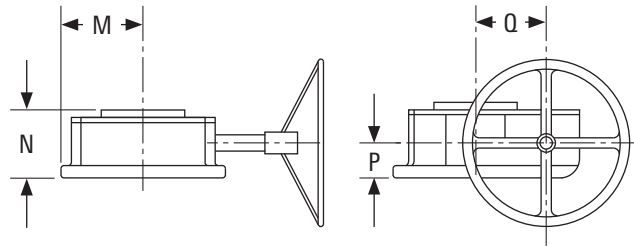

DYNATORQUE accessories gearbox. Stem size 1 in, 1.5 in, 2 in, and 3 in.

Manual Gear Dimensions

Stem Size, in [mm]	Model	Effective Ratio	Number of Turns per 90°	Dimension, in [mm]				Weight, lbm [kg]
				M	N	P	Q	
1.0 [25.4]	DT21	22.5:1	15	3.56 [90]	3.54 [90]	1.63 [41]	3.63 [92]	36 [16]
1.5 [38.1]	DT21	22.5:1	15	3.56 [90]	3.54 [90]	1.63 [41]	3.63 [92]	36 [16]
2.0 [50.8]	DT40	27.6:1	19.75	5.68 [144]	4.83 [123]	2.25 [57]	4.63 [118]	75 [34]
3.0 [76.2]	DT54	91.2:1	79.5	5.66 [144]	6.83 [173]	4.94 [125]	4.30 [109]	108 [49]

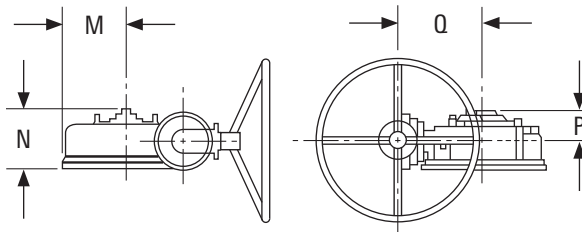

DYNATORQUE accessories gearbox. Stem size: 3 in and 4 in.

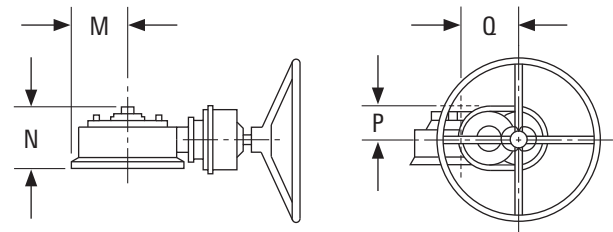

DYNATORQUE accessories gearbox. Stem size: 5 in, 7.5 in, and 9 in.

Manual Gear Dimensions

Stem Size, in [mm]	Model	Effective Ratio	Number of Turns per 90°	Dimension, in [mm]				Weight, lbm [kg]
				M	N	P	Q	
4.0 [101.6]	WG1/B6	110:1	112.5	9.13 [232]	8.69 [221]	4.69 [119]	12.64 [321]	211 [96]
5.0 [127.0]	WG1/S12	153:1	190	9.69 [246]	10.25 [260]	5.50 [140]	9.50 [241]	364 [165]
7.5 [190.5]	WG1/S12	297:1	297	12.88 [327]	12.63 [321]	6.63 [168]	14.00 [356]	581 [264]
9.0 [228.6]	WG1/S12	432:1	428t	16.37 [416]	14.77 [375]	7.39 [188]	19.50 [495]	793 [360]

Notes

CAMERON T30 Series



slb.com/valves

*Mark of Schlumberger
Other company, product, and service names
are the properties of their respective owners.
Copyright © 2021 Schlumberger. All rights reserved. 18-VL-418654

 **CAMERON**
A Schlumberger Company