

WKM Saf-T-Seal Gate Valves

Through-conduit, double block-and-bleed slab gate valves with fully protected seat faces for long-lasting, drop-tight shutoff in liquid pipelines

TECHNOLOGY

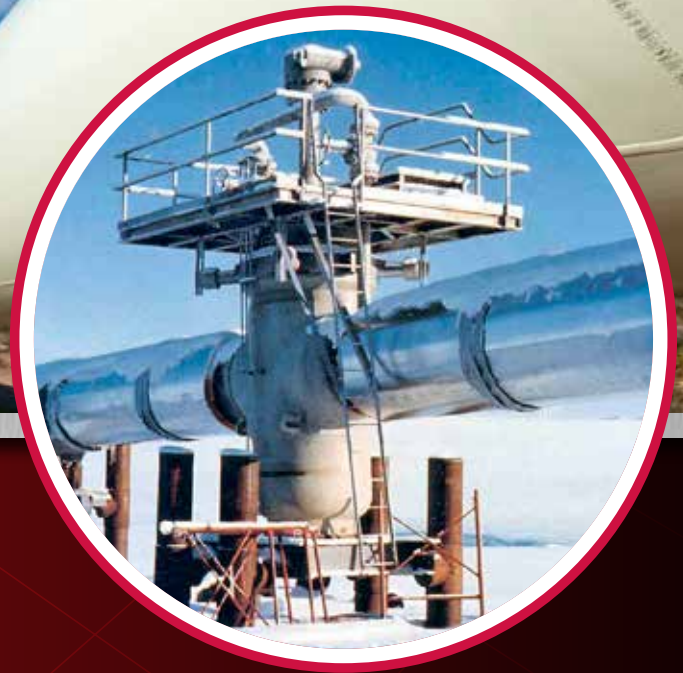

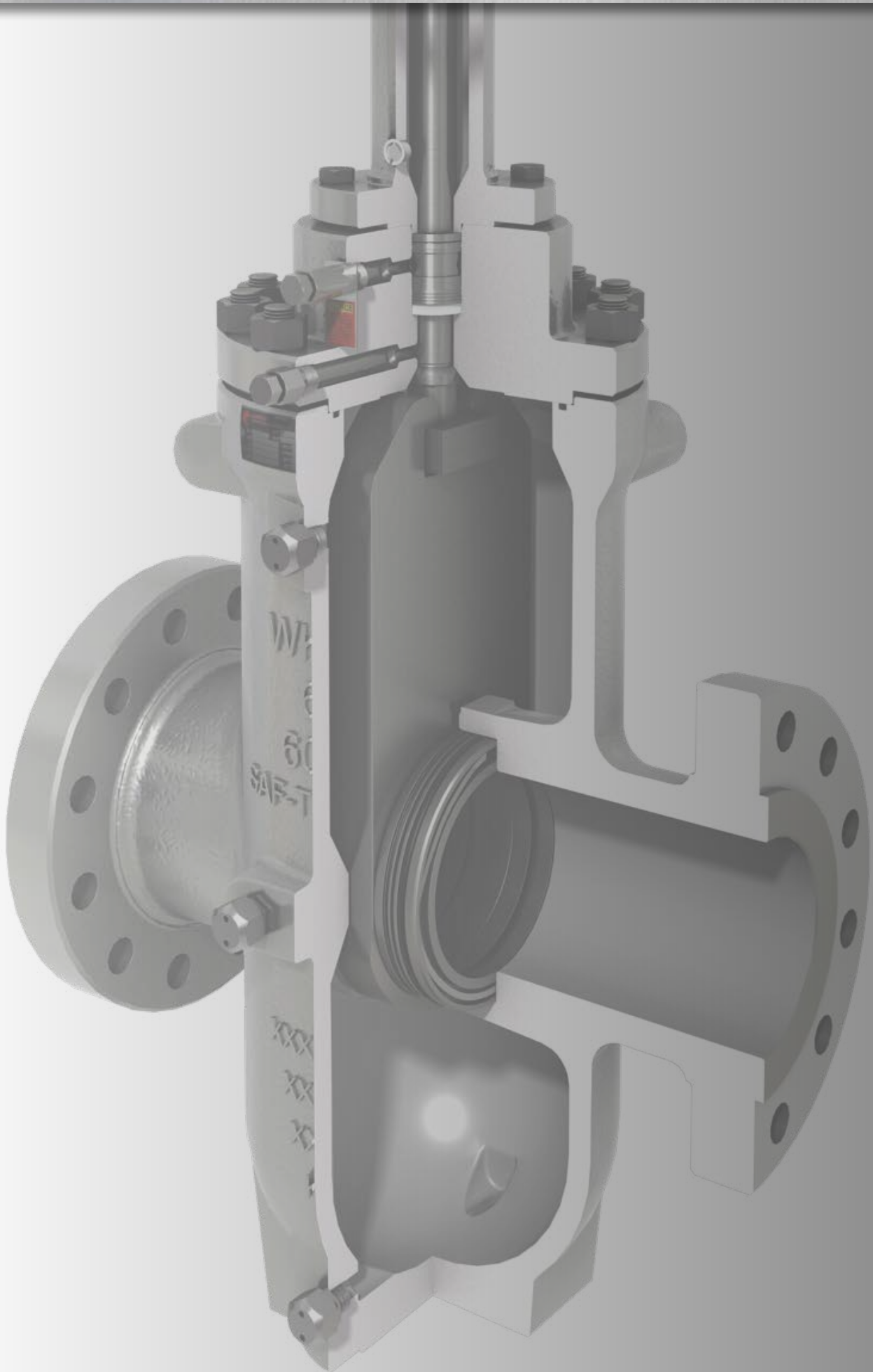

Table of Contents

WKM SAF-T-SEAL GATE VALVES

Introduction.....	3
Design	4
Features.....	5
Options.....	6
C6, C2B and C2C Models	
Automatic Relief of Excess Body Pressure	7
C6B Model	
Automatic Relief of Excess Body Pressure	8
Single Spring-Loaded (SLS) Seal.....	9
2" to 4" (50 mm to 100 mm) Classes 600, 900 and 1500	
Model M (Handwheel Operated).....	10
6" to 12" (150 mm to 300 mm) Classes 150, 300, 600, and 900	
Models C6 and C6B (Handwheel and Bevel Gear Operated).....	11
14" to 36" (350 mm to 900 mm) Classes 150 and 300	
Models C6B and C2B (Bevel Gear Operated).....	12
14" to 36" (350 mm to 900 mm) Classes 600 and 900	
Models C68 and C6B (Handwheel and Bevel Gear Operated).....	13
WKM Saf-T-Gard Actuators.....	14
Pneumatic Diaphragm Actuator	15
Pneumatic Piston Actuator.....	19

Table of Contents

Operating Size Requirements	20
Topworks Model M.....	22
Topworks Model C6.....	23
Topworks Model C6B.....	24
Flow Coefficients (C_v).....	26
Flow Coefficients (K_v).....	27
Trim Chart	28
Common Trims	29
Partial Open Flow Characteristics	30
CAMSERV Aftermarket Services for Valves and Actuation.....	31
Trademark Information	32

WKM Saf-T-Seal Gate Valves



Ville Platte, La.,
USA

Cameron is a leading provider of valves and measurement systems to the oil and gas industry. Our products are primarily used to control, direct and measure the flow of oil and gas as it is moved from individual wellheads through flowlines, gathering lines and transmission systems to refineries, petrochemical plants and industrial centers for processing.

Cameron provides a wide range of valves for use in natural gas, LNG, crude oil and refined products transmission lines. The traditional CAMERON® fully welded ball valve product line has been combined with the GROVE®, RING-O®, TOM WHEATLEY®, ENTECH™ and TK® product lines. This broad offering has strengthened Cameron's ability to serve as a single source for customer requirements. Cameron also provides critical service valves for refinery, chemical and petrochemical processing businesses, and for associated storage terminal applications, particularly through the ORBIT® and GENERAL VALVE® lines. These brands are complemented by WKM®, TBV™ and TEXSTEAM™ valve products and considerably expand the scope of our product offerings.

Cameron's WKM Saf-T-Seal™ gate valve's smooth continuous bore reduces turbulence. Additionally, the seat faces are outside the flow stream and are protected from contact with the lading whether the valve is in the open or closed position. The WKM Saf-T-Seal gate valve's full bore makes it possible to run pigs, scrapers or hot tap cutters through the valves without danger of damaging the valve, lodging the scraper, or jamming it with metal cuttings.

DESIGN

Cameron's WKM Saf-T-Seal valve's through-conduit design provides the following specific advantages that result in reliable performance and long life:

Protection of Seat Faces

- Seat faces are outside the flow stream and in full contact with the gate, in both open and closed positions, greatly extending the seat life.

Smooth, Continuous Conduit for Flow

- Destructive turbulence is reduced. In a full-bore valve, pressure drop through the valve is no greater than that through an equal length of equal diameter pipe.

Block-and-Bleed Capability

- In the closed position, the valve forms a tight seal on both seats simultaneously. This allows the body cavity to be bled.

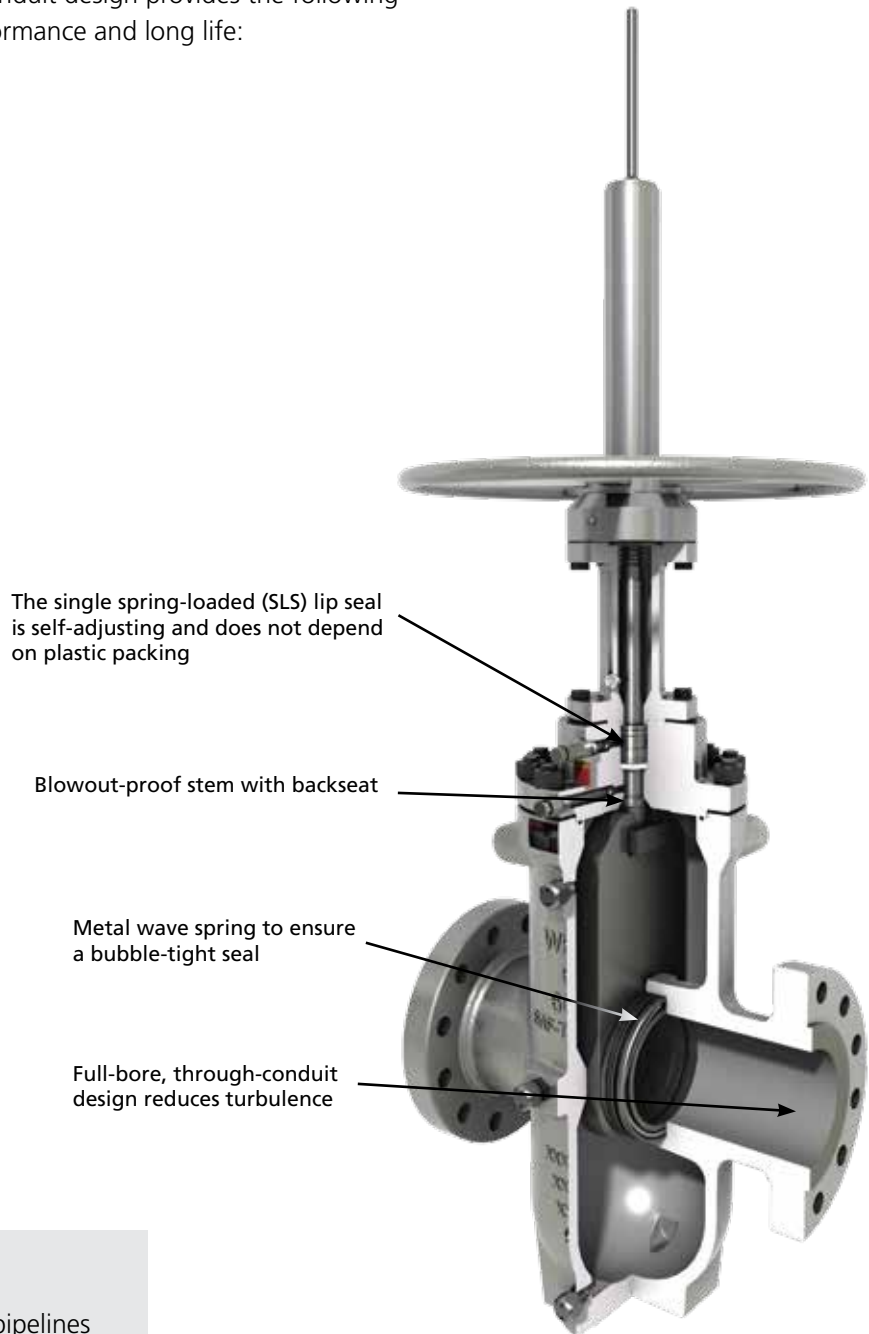

Commonly Used Applications

- Mainline and manifold valves in liquids pipelines
- Storage wells (salt domes, etc.)
- Water flood
- Safety valves (emergency shutdown valves (ESDVs) pipelines, wellheads and salt domes)

FEATURES

1. Through-Conduit Slab Gate Valve

- Provides a tight pressure-activated seal
- Full-bore design reduces pressure drop and allows passage of all types of scrapers (pigs)
- Nickel-plated internals

2. Cameron's SLS Stem Seal System or Vee Packing with Injectable Plastic Packing

3. Double-Sealing, Replaceable, Floating Seats

- Block-and-bleed per API 6D
- Simple one-piece design is resistant to dirty service
- Insert initiates the seal and helps clean the gate
- Excess body pressure is automatically vented upstream
- Seats may be lubricated to promote long life, reduce operating torques, or effect a seal in an emergency situation
- Easily removed and replaced while the valve is in-line
- Double seal established by initial plastic-to-metal seal in addition to metal-to-metal seal, both upstream and downstream

4. Bolted Bonnet Valve is In-Line Repairable

- Seal is made by an O-ring or flat metal gasket for standard applications (spiral-wound metal gasket with a non-asbestos filler for high-temperature applications)

5. Single-Piece Cast Body Center Section

- Provides the necessary strength to resist pipeline bending moments
- Smooth shape reduces stress concentrations
- Made from pressure vessel quality steel

6. Valve Stroke is Established by Manufacturing Tolerances

- Cannot get out of adjustment

7. Upgrades

- Stem backseat with test port
- SLS stem seal contained entirely in the bonnet, reducing a potential leak path
- Seat with wave spring to seal on low-pressure air
- Complies to API 6D and B16.34

OPTIONS

- Position indicator rods standard on handwheel- and bevel gear-operated valves
- Handwheel operators, bevel gear operators, or less gearing (bare stem)
- Saf-T-Gard hydraulic actuators or piston or diaphragm pneumatic actuators for surface safety applications
- Lubrication/packing/drain extensions
- Stem/yoke tube extensions
- Variety of coatings (coal tar epoxy for buried service, two- to three-part coating systems for marine environments, inorganic zinc-rich epoxy, etc.)
- Retrofits available for stem and body fitting extensions on buried service or difficult-to-reach valves, 6" (150 mm) increments
- HF-6 overlay available for gate and seal sealing surfaces

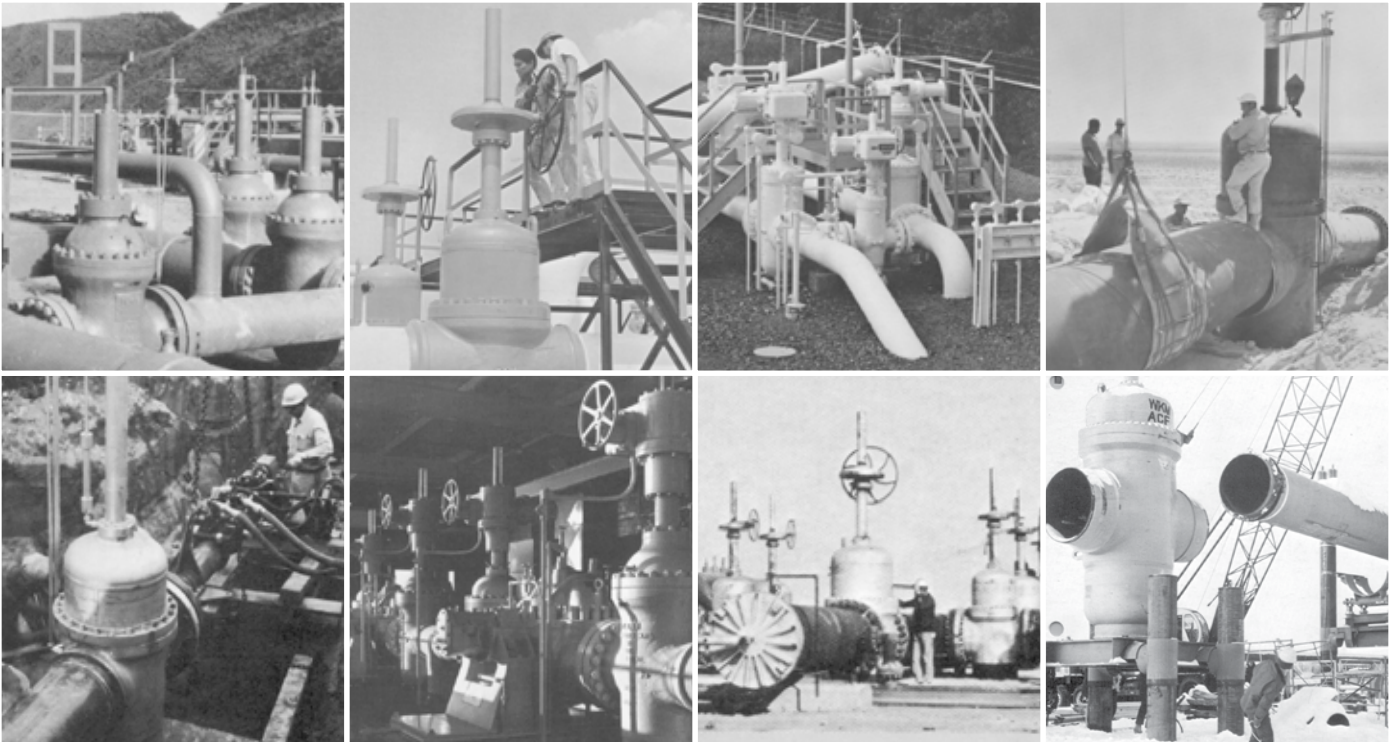

WKM Saf-T-Seal valves have a legacy of solid, innovative solutions around the globe.

C6, C2B and C2C Models

AUTOMATIC RELIEF OF EXCESS BODY PRESSURE

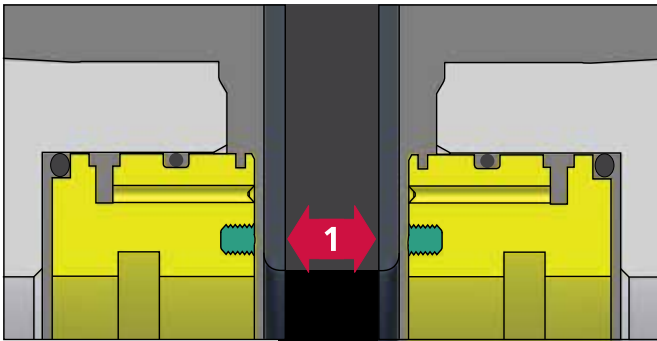

1. When the gate is in the closed position and there is an equal pressure through the valve, an initial seal (1) is formed by the raised plastic ring on the faces of the seats. The seat inserts clean both sides of the gate each time the valve is opened or closed.

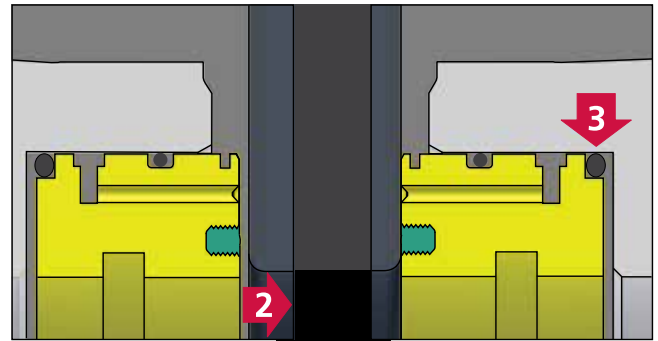

2. As line pressure (2) is applied to the valve, it acts on the gate, forcing it against the plastic ring on the downstream seat and compressing it until the gate rests against the steel seat. Thus, a double seal is formed; first, a plastic-to-metal seal then metal-to-metal. The seal also is forced firmly into its recess. The O-ring (3) prevents any downstream flow around the seat.

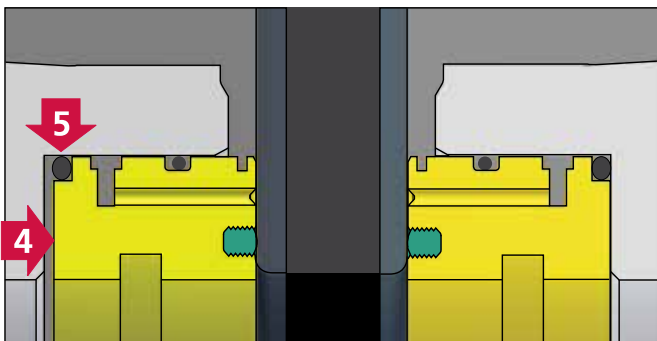

3. An upstream seal is provided by the force of line pressure acting against the upstream seat (4), moving the seat against the gate and providing a tight plastic-to-metal seal. At the same time, the O-ring (5) forms a tight seal with the seat recess.

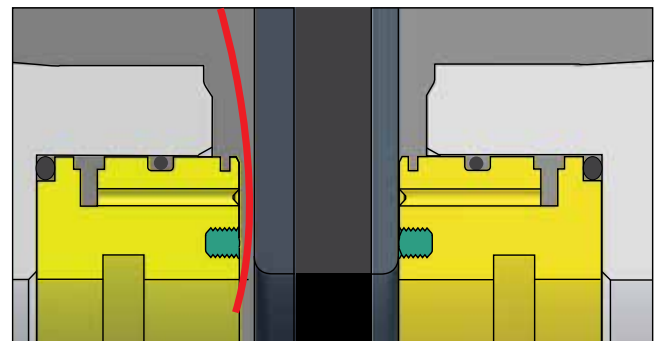

4. The valve automatically relieves itself of excessive body pressure. When body pressure exceeds line pressure, from causes such as thermal expansion, the upstream seat is forced back into its recess and the excess pressure in the body is bled between the seat and the gate into the line.

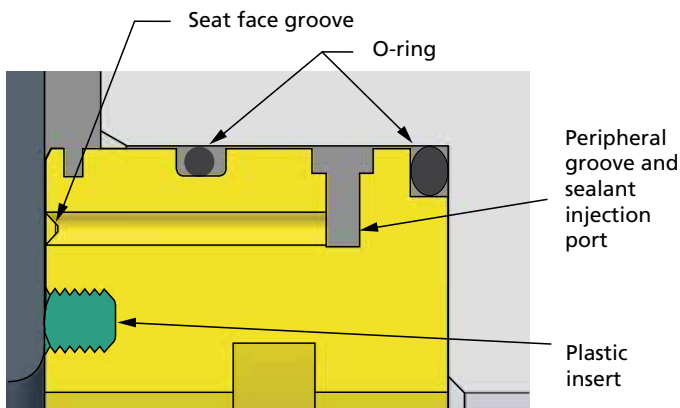

Emergency Sealant Injection

In valves 6" (150 mm) and larger, the sealant can be pumped through body fittings directly into a groove on the face of the seat. In smaller valves, the sealant is injected through fittings into the valve body.

Repacking Under Pressure

The WKM Saf-T-Seal gate valve is equipped with Cameron's SLS stem packing in an enclosed packing box. Plastic packing is not required. Plastic stem packing can be added while the valve is under pressure in case of an emergency.

C6B Model

AUTOMATIC RELIEF OF EXCESS BODY PRESSURE

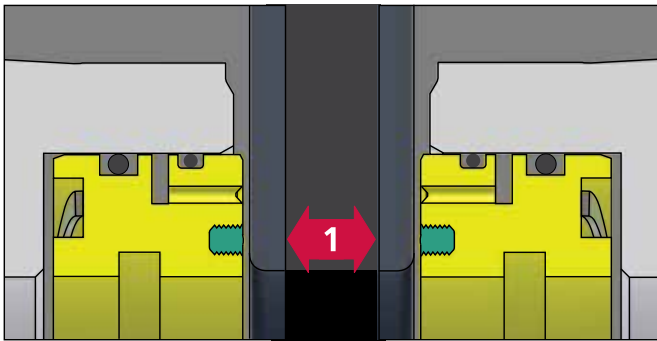

1. When the gate is in the closed position and there is an equal pressure through the valve, an initial seal (1) is formed by the raised plastic ring on the faces of the seats. The seat inserts clean both sides of the gate each time the valve is opened or closed.

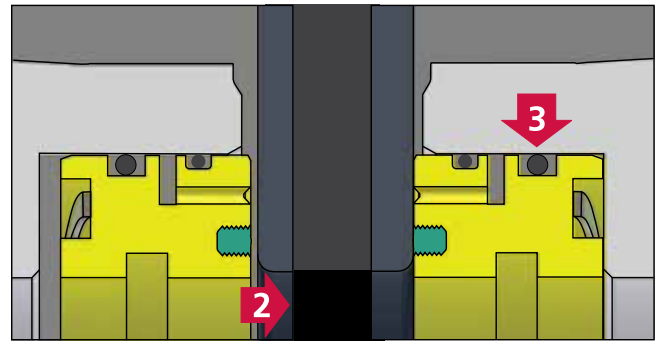

2. As line pressure (2) is applied to the valve, it acts on the gate, forcing it against the plastic ring on the downstream seat and compressing it until the gate rests against the steel seat. Thus, a double seal is formed; first, a plastic-to-metal seal then metal-to-metal. The seal is also forced firmly into its recess. The O-ring (3) prevents any downstream flow around the seat.

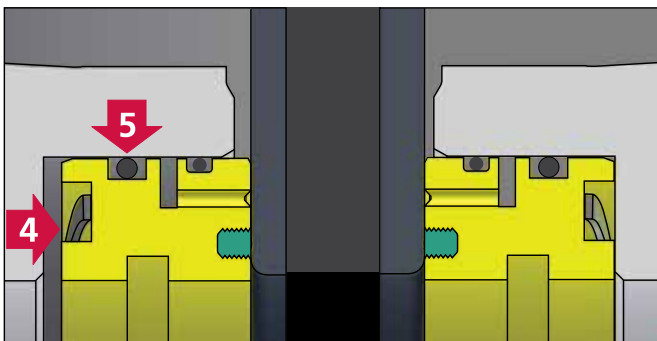

3. An upstream seal is provided by the force of line pressure acting against the upstream seat (4), moving the seat against the gate and providing a tight plastic-to-metal seal. At the same time, the O-ring (5) forms a tight seal with the seat recess.

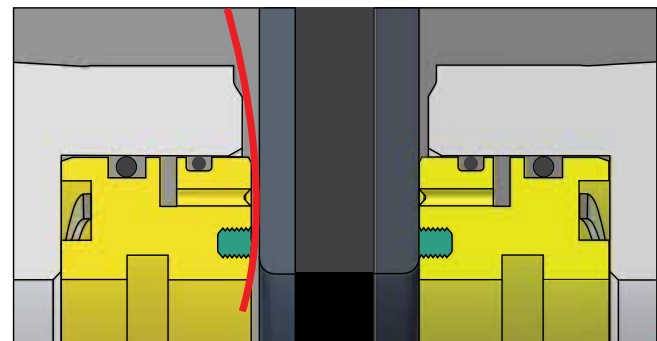

4. The valve automatically relieves itself of excessive body pressure. When body pressure exceeds line pressure from causes such as thermal expansion, the upstream seat is forced back into its recess and the excess pressure in the body is bled between the seat and the gate into the line.

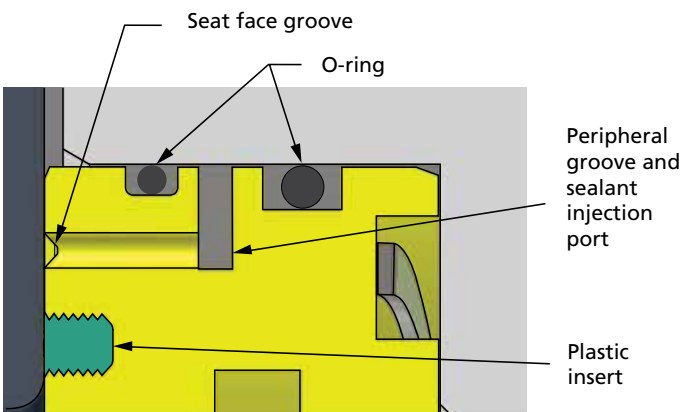

Emergency Sealant Injection

In valves 6" (150 mm) and larger, the sealant can be pumped through body fittings directly into a groove on the face of the seat. In smaller valves, the sealant is injected through fittings into the valve body.

Repacking Under Pressure

The WKM Saf-T-Seal gate valve is equipped with Cameron's SLS stem packing in an enclosed packing box. Plastic packing is not required. Plastic stem packing can be added while the valve is under pressure in case of an emergency.

Single Spring-Loaded (SLS) Seal

FEATURES AND BENEFITS

The SLS stem seal system is designed to provide optimum performance while requiring reduced maintenance. This seal is hydrocarbon fugitive emissions-tested and has demonstrated seal ability up to 500 ppm leakage.

Testing and Certifications

- Fire tests per API 6FA, BS 6755 Part 11
- ISO 10497

Design

- Single spring-loaded lip seal
- Lantern ring
- Chevron ring(s)
- Lower pedestal
- Upper adapter

Features

- Self-adjusting seal designed to reduce maintenance
- No plastic packing required to establish an effective seal*
- Four separate sealing bands to promote reliability
- Filled PTFE shell backed with a corrosion-resistant alloy spring (making it suitable for virtually all line media)
- Metal spring provides an initial seal and uniform loading over a wide temperature range
- Lantern ring acts as a spacer in conjunction with the upper adapter as a bearing to center the stem
- Lower pedestal support seal acts as a stem scraper to keep contaminants away from sealing members
- Chevron ring(s) act as an emergency seal, should it be necessary to inject plastic packing, and keeps foreign matter away from the seal

Model C6B Details

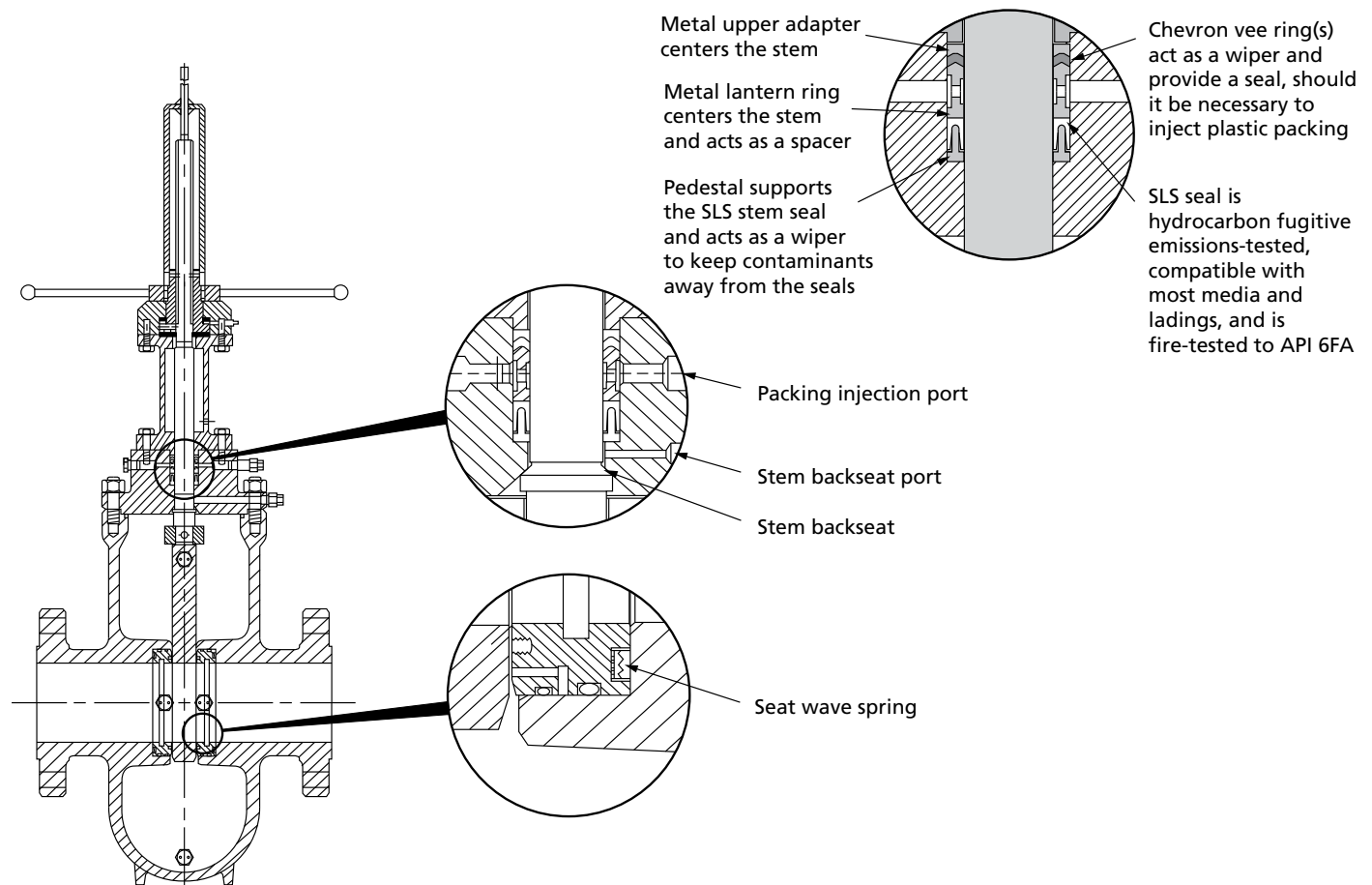

Standard on C6B model. Can be retrofitted or requested for C6, C2B and C2C models.

* Plastic packing can be injected into packing box to affect a temporary seal while the valve is under pressure.

2" to 4" (50 mm to 100 mm) Classes 600, 900 and 1500

MODEL M (HANDWHEEL OPERATED)

Max. WP at 100° F (38° C)	
Class 600:	1500 psi CWP 2250 psi Test
Class 900:	2250 psi CWP 3375 psi Test
Class 1500:	3750 psi CWP 5625 psi Test

PRINCIPAL DIMENSIONS

N = Number of turns to fully open or close valve

SN = Stem nut

BGO = Bevel gear operator

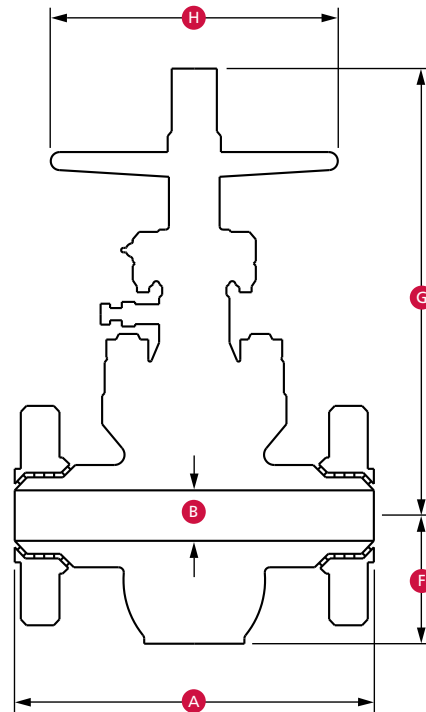

Class 600

Size in. (mm)	A	B	F	G	* H	N	Weight lb (kg)		
							FE	WE	F x W
2 (50)	11-1/2 (292)	2-1/16 (52)	4-13/16 (122)	17-3/4 (451)	12 (305)	15-3/4	90 (41)	72 (33)	84 (38)
3 (80)	14 (356)	3-3/16 (81)	6-15/16 (176)	24-3/8 (619)	12 (305)	20-1/4	180 (82)	144 (65)	155 (70)
4 (100)	17 (432)	4-1/8 (105)	8-5/8 (219)	29 (737)	14 (356)	19-1/2	345 (156)	259 (117)	245 (111)

Class 900

2 (50)	14-1/2 (368)	2-1/16 (52)	5-1/16 (129)	17-3/4 (451)	12 (305)	15-3/4	150 (68)	72 (33)	105 (48)
3 (80)	15 (381)	3-3/16 (81)	7-5/16 (186)	24-3/8 (619)	12 (305)	20-1/4	265 (120)	193 (88)	247 (112)
4 (100)	18 (457)	4-1/8 (105)	9-1/16 (230)	29 (737)	18 (457)	19-1/2	515 (234)	390 (177)	417 (189)

Class 1500

2 (50)	14-1/2 (368)	2-1/16 (52)	5-1/16 (129)	17-3/4 (451)	12 (305)	15-3/4	220 (100)	150 (68)	154 (70)
3 (80)	18-1/2 (470)	3-3/16 (81)	7-5/16 (186)	24-3/8 (619)	12 (305)	20-1/4	450 (204)	328 (149)	370 (168)
4 (100)	21-1/2 (546)	4-1/8 (105)	9-1/16 (230)	29 (737)	18 (457)	19-1/2	720 (327)	547 (248)	583 (264)

* Some valves may require a gear operator to meet API 6D.

6" to 12" (150 mm to 300 mm) Classes 150, 300, 600 and 900

MODELS C6 AND C6B (HANDWHEEL AND BEVEL GEAR OPERATED)

Max. WP at 100° F (38° C)	
Class 150:	290 psi CWP 450 psi Test
Class 300:	750 psi CWP 1125 psi Test
Class 600:	1500 psi CWP 2250 psi Test
Class 900:	2250 psi CWP 3375 psi Test

PRINCIPAL DIMENSIONS

N = Number of turns to fully open or close valve

SN = Stem nut

BGO = Bevel gear operator

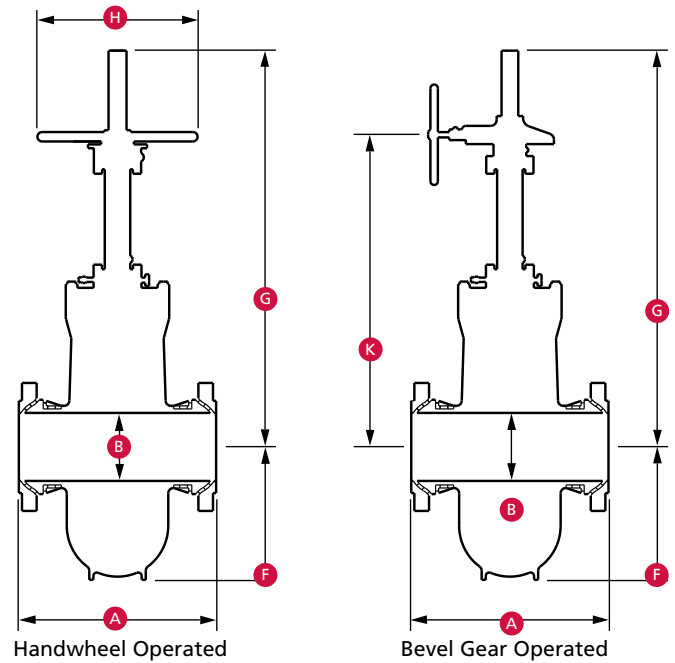

Class 150 (Model C6)

Size in. (mm)	A	B	F	G (HWO)	G (BGO)	* H	K	N (SN)	N (BGO)	Weight lb (kg)		
										FE	WE	W XF
6 (150)	10-1/2 (267)	6 (152)	13-1/2 (343)	45-3/8 (1153)	46-3/8 (1178)	24 (610)	30-3/4 (781)	29	116	245 (111)	215 (98)	230 (104)
8 (200)	11-1/2 (292)	8 (203)	16-1/2 (419)	52-3/8 (1330)	55-3/8 (1407)	24 (610)	35-7/8 (911)	37	148	365 (166)	320 (145)	342 (155)
10 (250)	13 (330)	10 (254)	19-1/2 (495)	59-1/2 (1511)	60-1/2 (1537)	24 (610)	40-7/8 (1038)	45	180	515 (234)	459 (208)	488 (221)
12 (300)	14 (356)	12 (305)	22-3/4 (578)	68-5/8 (1743)	69-5/8 (1768)	24 (610)	46-1/8 (1172)	53	212	677 (307)	594 (269)	635 (288)

Class 300 (Model C6)

6 (150)	15-7/8 (403)	6 (152)	13-1/2 (343)	45-3/8 (1153)	46-3/8 (1178)	24 (610)	30-3/4 (781)	29	116	316 (143)	271 (123)	294 (133)
8 (200)	16-1/2 (419)	8 (203)	16-1/2 (419)	54-3/8 (1381)	55-3/8 (1407)	24 (610)	35-7/8 (911)	37	148	520 (236)	459 (208)	489 (222)
10 (250)	18 (457)	10 (254)	19-1/2 (495)	59-1/2 (1511)	60-1/2 (1537)	24 (610)	40-7/8 (1038)	45	180	773 (351)	695 (315)	731 (332)
12 (300)	19-3/4 (502)	12 (305)	22-5/8 (578)	68-5/8 (1743)	69-5/8 (1768)	24 (610)	46-1/8 (1172)	53	212	1035 (469)	930 (422)	983 (446)

Class 600 (Model C6B)

Size in. (mm)	A	B	F	G (HWO)	G (BGO)	* H	K	N (SN)	N (BGO)	Weight lb (kg)		
										FE	WE	W XF
6 (150)	22 (559)	6 (152)	13-5/8 (346)	45-3/8 (1153)	46-3/8 (1178)	24 (610)	30-3/4 (781)	29	116	600 (272)	439 (199)	650 (295)
8 (200)	26 (660)	8 (203)	16-3/4 (425)	56-3/8 (1432)	57-3/8 (1457)	24 (610)	37-13/16 (960)	37	148	970 (440)	737 (334)	853 (387)
10 (250)	31 (787)	10 (254)	20 (508)	59-1/2 (1511)	61-1/2 (1562)	24 (610)	40-7/8 (1038)	45	180	1736 (787)	1584 (718)	1656 (751)
12 (300)	33 (838)	12 (305)	23-1/4 (591)	68-7/8 (1743)	70-1/2 (1791)	30 (762)	47-1/4 (1200)	53	318	2374 (1077)	2010 (912)	2156 (9143)

Class 900 (Model C6B)

6 (150)	24 (610)	6 (152)	13-7/8 (352)	45-1/8 (1146)	46-1/8 (1222)	24 (610)	30-3/4 (781)	29	116	650 (295)	500 (227)	575 (261)
8 (200)	29 (737)	8 (203)	17-1/8 (435)	56-1/8 (1426)	57-1/8 (1451)	24 (610)	37-13/16 (960)	37	148	1200 (544)	950 (431)	1050 (476)
10 (250)	33 (838)	10 (254)	20-1/2 (521)	59-1/2 (1511)	60-3/4 (1543)	30 (762)	42-1/16 (1068)	45	180	2150 (975)	1830 (830)	1980 (898)
12 (300)	38 (965)	12 (305)	23-3/4 (603)	71-3/4 (1822)	73-1/8 (1857)	30 (762)	48-1/2 (1232)	53	318	3250 (1474)	2500 (1134)	2650 (1202)

Flange dimensions conform to ASME B16.5, 1981. Information on power-actuated and other types of valves available on application.

* Some valves may require a gear operator to meet API 6D.

14" to 36" (350 mm to 900 mm) Classes 150 and 300

MODELS C6B AND C2B
(BEVEL GEAR OPERATED)

Max. WP at 100° F (38° C)	
Class 150:	290 psi CWP 450 psi Test
Class 300:	750 psi CWP 1125 psi Test

PRINCIPAL DIMENSIONS

N = Number of turns to fully open or close valve

SN = Stem nut

BGO = Bevel gear operator

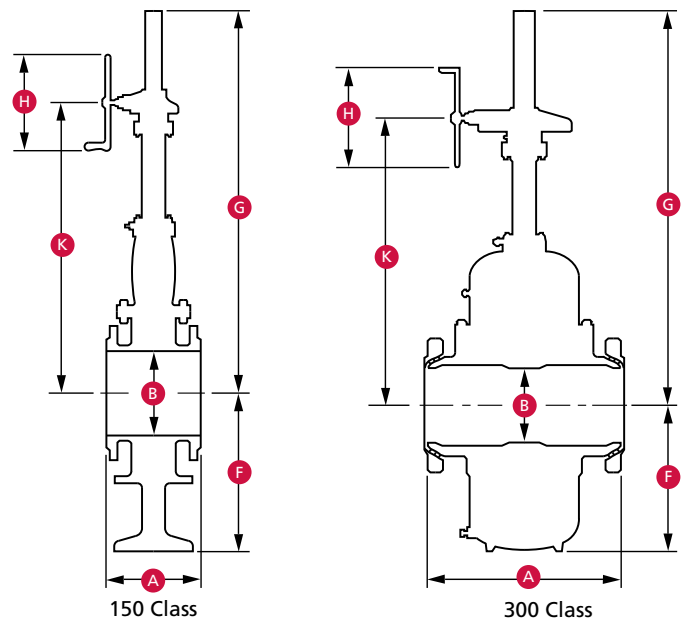

Class 150 (Model C6B)

Size in. (mm)	A	B	F	G	* H	K	N (SN)	N (BGO)	Weight lb (kg)		
									FE	WE	WXF
14 (350)	15 (381)	13-1/4 (337)	25-1/4 (641)	76 (1930)	24 (610)	51-3/4 (1314)	36-3/4	146-7/8	872 (396)	760 (345)	817 (371)
16 (400)	16 (406)	15-1/4 (387)	28-3/8 (721)	82-7/8 (2105)	24 (610)	56-7/8 (1445)	41-3/4	166-7/8	1309 (594)	1163 (528)	1235 (560)
18 (450)	17 (432)	17-1/4 (438)	31-3/8 (797)	90 (2286)	24 (610)	62 (1575)	46-1/16	184-3/8	1781 (808)	1603 (727)	1690 (767)
20 (500)	18 (457)	19-1/4 (489)	34-1/2 (876)	98-1/4 (2496)	24 (610)	67-1/4 (1708)	41-1/2	166	2351 (1066)	2119 (961)	2235 (1014)
24 (600)	20 (508)	23-1/4 (591)	41-1/8 (1045)	113 (2870)	24 (610)	78 (1981)	50-1/4	301-1/2	2892 (1312)	2514 (1140)	2703 (1226)
26 (650)	22 (559)	25 (635)	43-13/16 (1113)	120-1/4 (3054)	24 (610)	84-5/8 (2149)	-	-	3521 (1597)	3172 (1439)	3327 (1509)
28 (700)	24 (610)	27 (686)	46-7/8 (1191)	127-1/4 (3232)	24 (610)	90-1/8 (2289)	57-7/8	347-1/4	4098 (1859)	3506 (1590)	3802 (1725)
30 (750)	26 (660)	29 (737)	50 (1270)	136-1/4 (3461)	24 (610)	95-1/2 (2426)	62-1/2	500	4916 (2230)	4231 (1919)	4573 (2074)
36 (900)	32 (813)	34-1/2 (876)	59 (1499)	157 (3988)	36 (914)	113-3/8 (2880)	46-1/8	368-3/4	5842 (2650)	5264 (2388)	5521 (2504)

Flange dimensions on valves through 24" (600 mm) conform to American National Standards Institute Standard 816.5, 1974.
Larger sizes conform to MSS-SP-44.

Class 300 (Model C2B)

14 (350)	30 (762)	13-1/4 (337)	25-1/2 (648)	75-5/8 (1921)	24 (610)	49-1/2 (1257)	29-3/8	117-1/2	1454 (660)	1266 (574)	1361 (617)
16 (400)	33 (838)	15-1/4 (387)	28-1/8 (714)	80-5/8 (2048)	24 (610)	54-1/2 (1384)	41-3/4	166-7/8	2182 (990)	1939 (880)	2058 (933)
18 (450)	36 (914)	17-1/4 (438)	31 (787)	88 (2235)	24 (610)	60-3/4 (1543)	37-3/8	224-1/4	2969 (1347)	2672 (1212)	2816 (1277)
20 (500)	39 (991)	19-1/4 (489)	34-1/2 (876)	97-3/4 (2483)	24 (610)	67 (1702)	41-1/2	249	3919 (1778)	3532 (1602)	3725 (1690)
24 (600)	45 (1143)	23-1/4 (591)	41-1/8 (1045)	114-1/8 (2899)	24 (610)	78-3/4 (2000)	50-1/4	402	5868 (2662)	5287 (2398)	5545 (2515)
26 (650)	49 (1245)	25 (635)	43-3/4 (1111)	120-1/4 (3054)	24 (610)	83-1/4 (2115)	-	-	6830 (3098)	5844 (2651)	6337 (2874)
28 (700)	53 (1346)	27 (686)	47 (1194)	129-3/4 (3296)	24 (610)	90-1/4 (2292)	-	-	8194 (3717)	7051 (3198)	7623 (3458)
30 (750)	55 (1397)	29 (737)	50-5/8 (1286)	139-1/8 (3534)	36 (914)	96-3/4 (2457)	39-1/16	312-1/2	9736 (4416)	8773 (3979)	9201 (4174)
36 (900)	68 (1727)	34-1/2 (876)	59-1/4 (1505)	161 (4089)	36 (914)	112-3/4 (2864)	46-1/8	368-3/4	15,441 (7004)	13,607 (6172)	14,524 (6588)

Flange dimensions conform to ASME B16.5, 1981.

Information on power-actuated and other types of valves available on application.

* Some valves may require a gear operator to meet API 6D.

14" to 36" (350 mm to 900 mm) Classes 600 and 900

MODELS C6 AND C6B (HANDWHEEL AND BEVEL GEAR OPERATED)

Max. WP at 100° F (38° C)	
Class 600:	1500 psi CWP 2250 psi Test
Class 900:	2250 psi CWP 3375 psi Test

PRINCIPAL DIMENSIONS

N = Number of turns to fully open or close valve

SN = Stem nut

BGO = Bevel gear operator

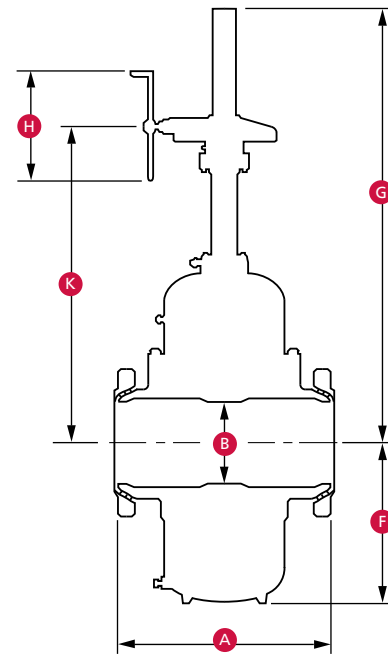

Class 600 (Model C6B)

Size in. (mm)	A	B	F	G	* H	K	N (SN)	N (BGO)	Weight lb (kg)		
									FE	WE	WXF
14 (350)	35 (889)	13-1/4 (337)	26 (660)	75-3/8 (1915)	24 (610)	51-1/2 (1308)	29-3/8	176-1/4	3232 (1466)	2828 (1283)	3030 (1374)
16 (400)	39 (991)	15-1/4 (387)	29-1/8 (740)	83-1/2 (2121)	24 (610)	56-3/4 (1441)	33-3/8	200-1/4	4023 (1825)	3515 (1594)	3767 (1709)
18 (450)	43 (1092)	17-1/4 (438)	32-3/8 (822)	91-1/2 (2324)	24 (610)	62-1/2 (1588)	37-3/8	224-1/4	5617 (2548)	4110 (1864)	5252 (2382)
20 (500)	47 (1194)	19-1/4 (489)	35-7/8 (911)	100-1/2 (2553)	24 (610)	69-3/8 (1762)	26	208	6984 (3168)	6070 (2753)	6449 (2925)
24 (600)	55 (1397)	23-1/4 (591)	42-1/4 (1073)	118 (2997)	36 (914)	83 (2108)	31-3/8	251-1/4	11,447 (5192)	10,014 (4542)	10,730 (4867)
26 (650)	57 (1448)	25 (635)	46 (1168)	124-5/8 (3165)	36 (914)	87-1/2 (2223)	33-9/16	268-3/4	13,124 (5953)	11,494 (5214)	10,024 (4547)
28 (700)	61 (1549)	27 (686)	49-1/4 (1251)	134 (3404)	36 (914)	93-1/2 (2375)	36-3/16	434	14,293 (6483)	12,232 (5548)	12,624 (5726)
30 (750)	65 (1651)	29 (737)	52-3/4 (1340)	142-3/4 (3626)	36 (914)	100-1/2 (2553)	39-1/16	468-3/4	14,457 (6558)	12,724 (5772)	13,591 (6165)
36 (900)	82 (2083)	34-1/2 (876)	61-3/4 (1568)	171-1/4 (4350)	36 (914)	117-1/2 (2985)	46-1/8	553-1/8	26,377 (11964)	23,967 (10871)	25,172 (11418)

Class 900 (Model C2C)

14 (350)	40-1/2 (1029)	12-3/4 (324)	25-9/16 (649)	79-5/8 (2022)	24 (610)	55-13/16 (1418)	20-7/8	166-7/8	-	-	-
16 (400)	44-1/2 (1130)	15-1/4 (387)	30-7/16 (773)	87-3/8 (2219)	24 (610)	60-3/16 (1529)	20-7/8	166-7/8	-	-	-
18 (450)	48 (1219)	17-1/4 (438)	33-7/8 (860)	56-15/16 (1446)	24 (610)	64-11/16 (1643)	23-3/8	187	-	-	-
20 (500)	52 (1321)	19-1/4 (489)	37-1/4 (946)	103-3/8 (2626)	36 (914)	71-1/8 (1807)	26	208	-	-	-
24 (600)	61 (1549)	23-1/4 (591)	46-1/4 (1175)	123-1/8 (3127)	36 (914)	86-3/8 (2194)	-	-	-	-	-

Flange dimensions conform to ASME B16.5, 1981.

Information on power-actuated and other types of valves available on application.

WKM Saf-T-Gard Actuators

Electric and Pneumatic

Cameron's WKM Saf-T-Seal™ gate valves can be equipped with two principal types of actuators: electric actuators and pneumatic or gas-powered motor drives.

Information Required for Sizing Electric Actuators

- Valve type: Saf-T-Seal
- Size: pipe size x bore size
- Pressure class
- Top-mounted or side-mounted
- Closing time in seconds
- Maximum differential pressure (psi)
- Type and make of actuator required
- Voltage:
 - Three-phase, 60-cycle 220 V/440 V
 - Three-phase, 50-cycle 220 V/440 V
 - Control voltage
 - Motor connection voltage
 - Any special requirements
- Enclosure:
 - Weather-proof
 - Explosion-proof, Class 1, Group D, Div. 2
 - ATEX
 - Certification required
- Accessories:
 - Reversing starter
 - Control transformer
 - Push-button station:
 - Three push buttons
 - Two lights
 - Limit switches:
 - Two train-gear limit switches (eight contacts)
 - Four train-gear limit switches (16 contacts)
- Special requirements

Information Required for Sizing Pneumatic Actuators

- Valve type: Saf-T-Seal
- Size: pipe size x bore size
- Pressure class
- Actual working pressure at which valve will be operated (psi)
- Available gas pressure to power motor drive: psi
- Top-mounted or side-mounted
- Closing time in seconds
- Maximum differential pressure (psi)
- Type and make of actuator required
- Accessories
- Special requirements

PNEUMATIC DIAPHRAGM ACTUATOR

MA 12 Series

For use with 2", 3" and 4"
(50 mm, 80 mm and 100 mm)
nominal gate valves
(Family Group Code Y55012).

Design Advantages

Stronger Actuator Mounting Arrangement

Unlike other designs, the mounting bolts on Cameron's actuators are positioned parallel to the centerline of the actuator, which loads the mounting bolts in tension. This design is not subject to bending or shear forces. This means it can withstand greater separation forces than other actuators on the market.

Corrosion-Resistant Materials

Cameron's Saf-T-Gard diaphragm actuators are manufactured to NACE MR0175. In addition, all non-stainless components are coated with Xylan to increase corrosion resistance.

Superior Diaphragm Design

Cameron's diaphragm material is stronger than most designs currently on the market, resulting in extended service life and higher operating pressures. Unique sealing grooves provide additional grip and improve the outer seal of the diaphragm housing.

Flexible Actuator Orientation

Connecting misaligned components with rigid tubing can be time-consuming and can induce high stress into the tubing connections. The MA lower ring is threaded to the bonnet, thus allowing rotation of the actuator to accommodate precise alignment.

Description

Cameron's Saf-T-Gard diaphragm actuator was developed by using the quality features of field proven products and then combining them with innovative technology. Particular attention has been given to safety, ease of maintenance and cost of manufacturing.

Designed for use with all manufacturers' gate valves in nominal sizes of 2" to 6" (50 mm to 150 mm), its simple design and operating principle helps to avoid most of the problems commonly associated with piston type actuators such as galling, misalignment, distortion and O-ring failures.

The Saf-T-Gard diaphragm actuators are interchangeable with other models in the product line, which reduces the amount of spare parts necessary for maintenance.

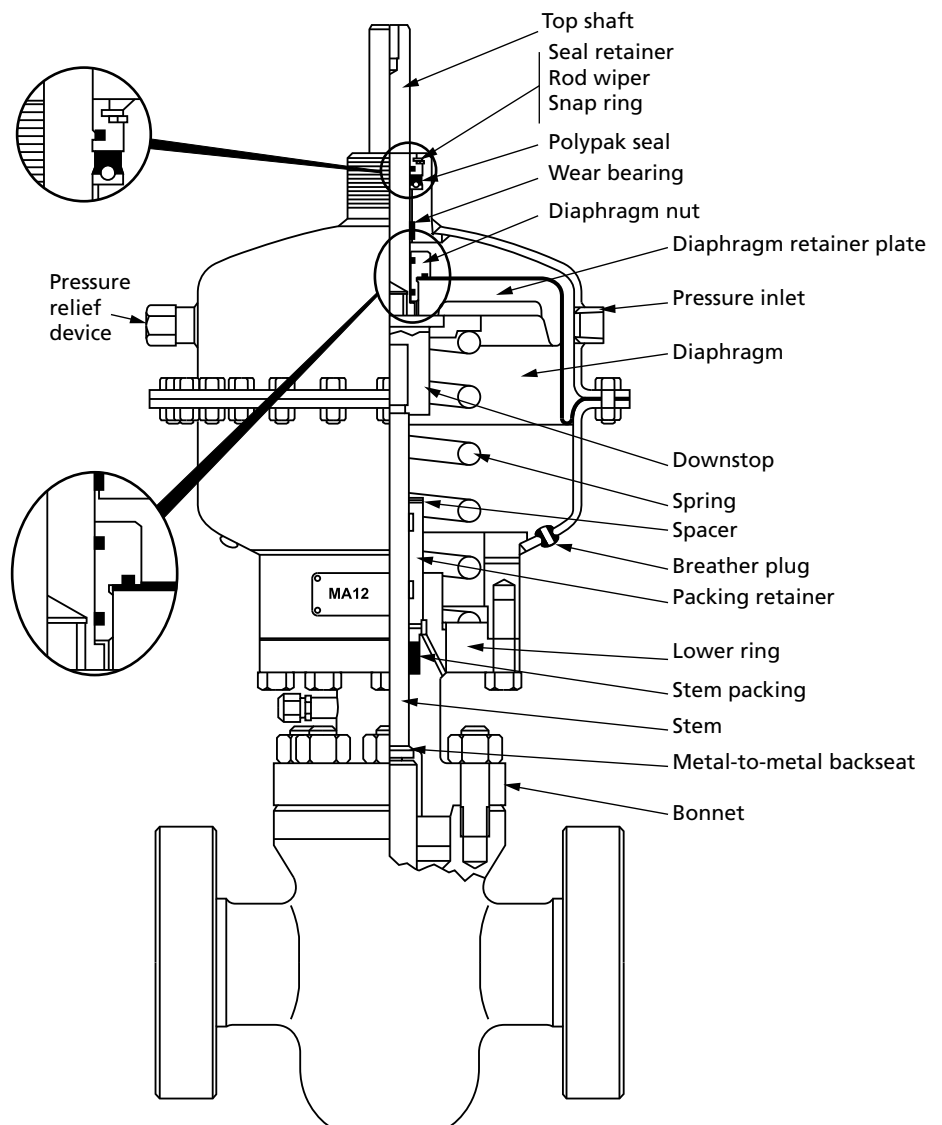

MA 16 Series

For use with 2", 3", 4" and 5" (50 mm, 80 mm, 100 mm and 125 mm) nominal gate valves (Family Group Code Y55016).

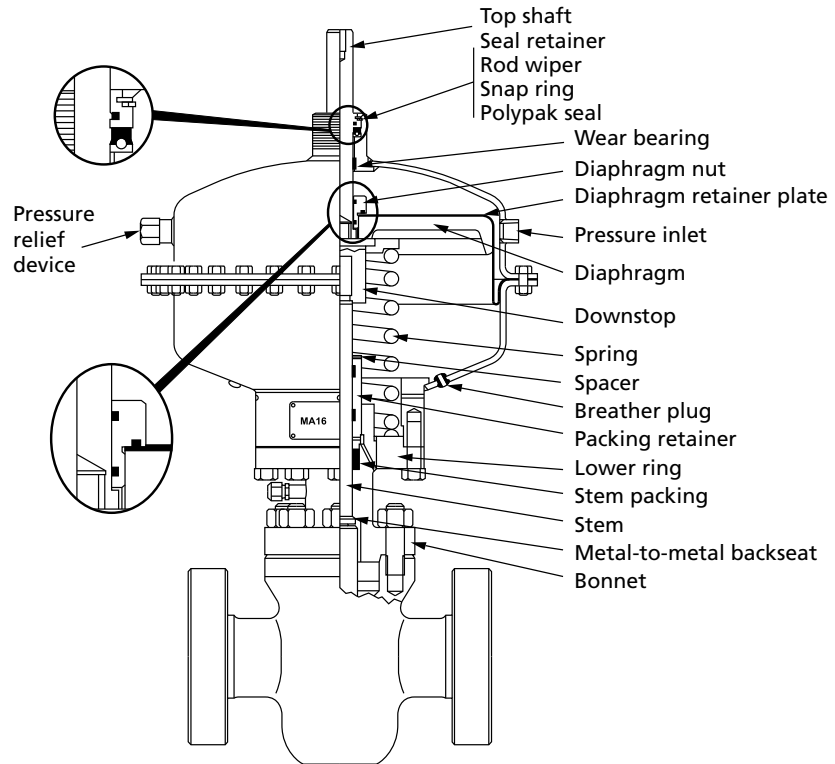

MA 20 Series

For use with 2", 3", 4", 5" and 6" (50 mm, 80 mm, 100 mm, 125 mm and 150 mm) nominal gate valves (Family Group Code Y55020).

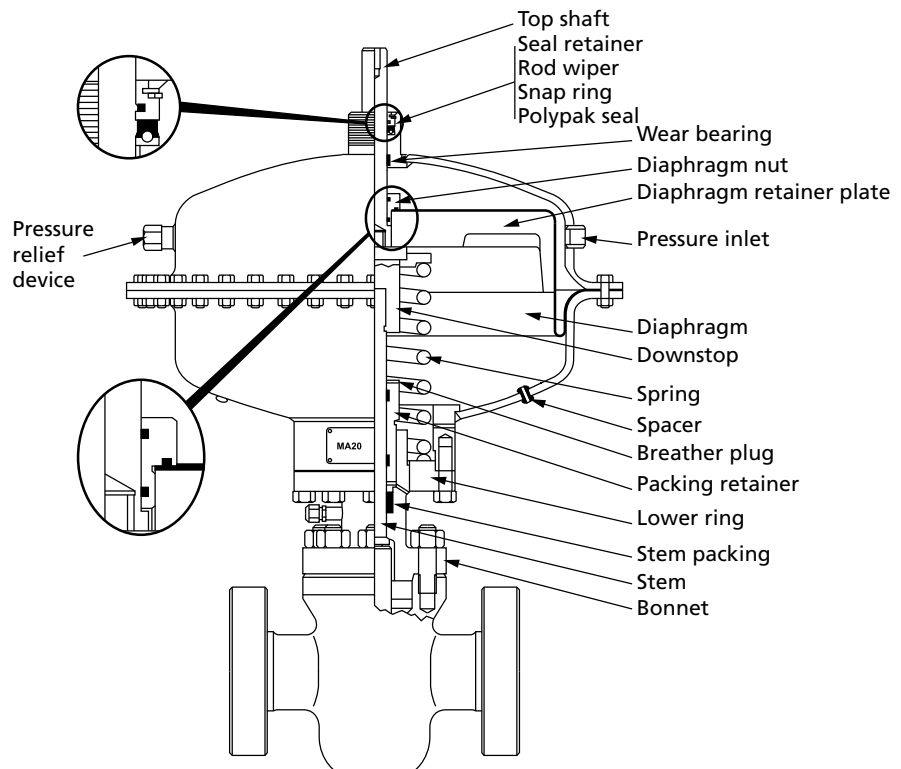

MA 1212 Series

For use with 2", 3" and 4"
(50 mm, 80 mm and 100 mm)
nominal gate valves
(Family Group Code Y55012).

The MA 1212 series doubles
the area affected by applied
control pressure.

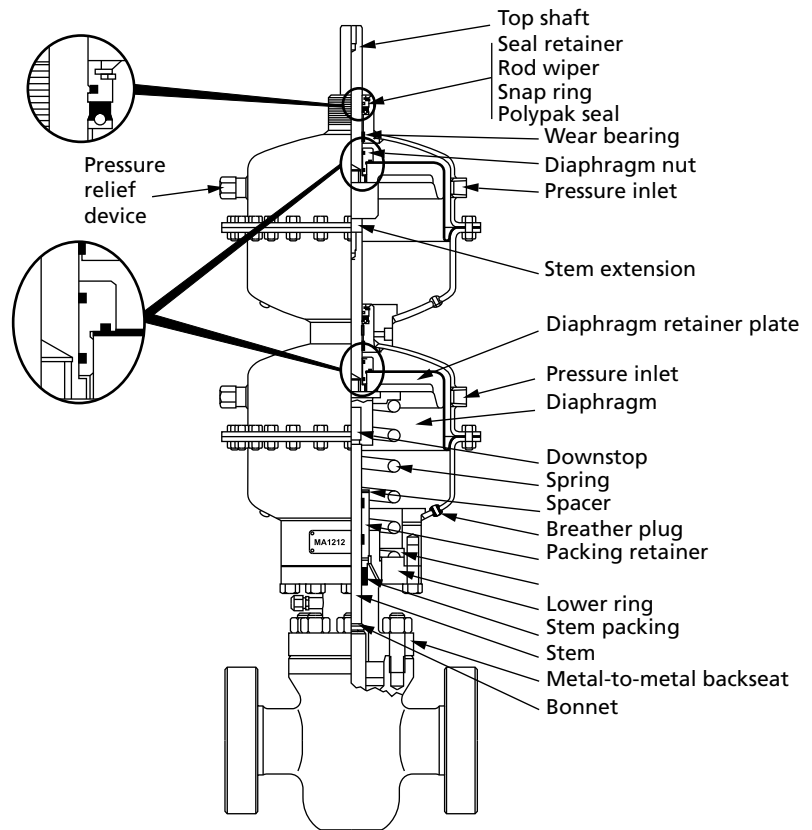

MA 2012 Series

For use with 2", 3" and 4"
(50 mm, 80 mm and 100 mm)
nominal gate valves
(Family Group Code Y55020).

The MA 2012 series increases
the area affected by applied
control pressure.

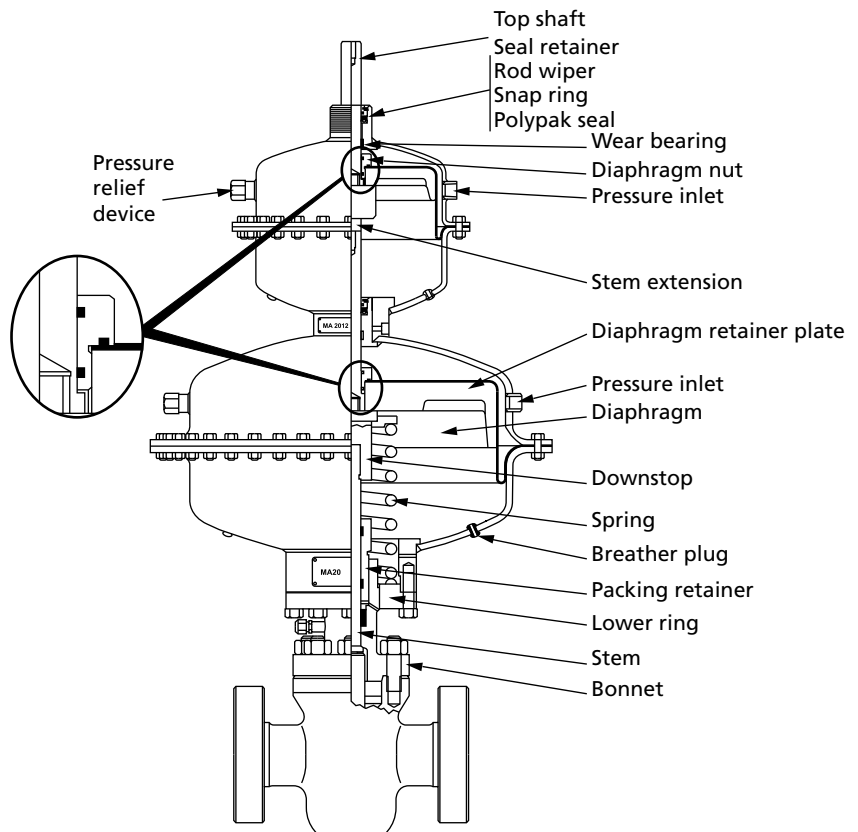

MA 2016 Series

For use with 2", 3", 4" and 6" (50 mm, 80 mm, 100 mm and 150 mm) nominal gate valves (Family Group Code Y55020).

The MA 2016 series increases the area affected by applied control pressure.

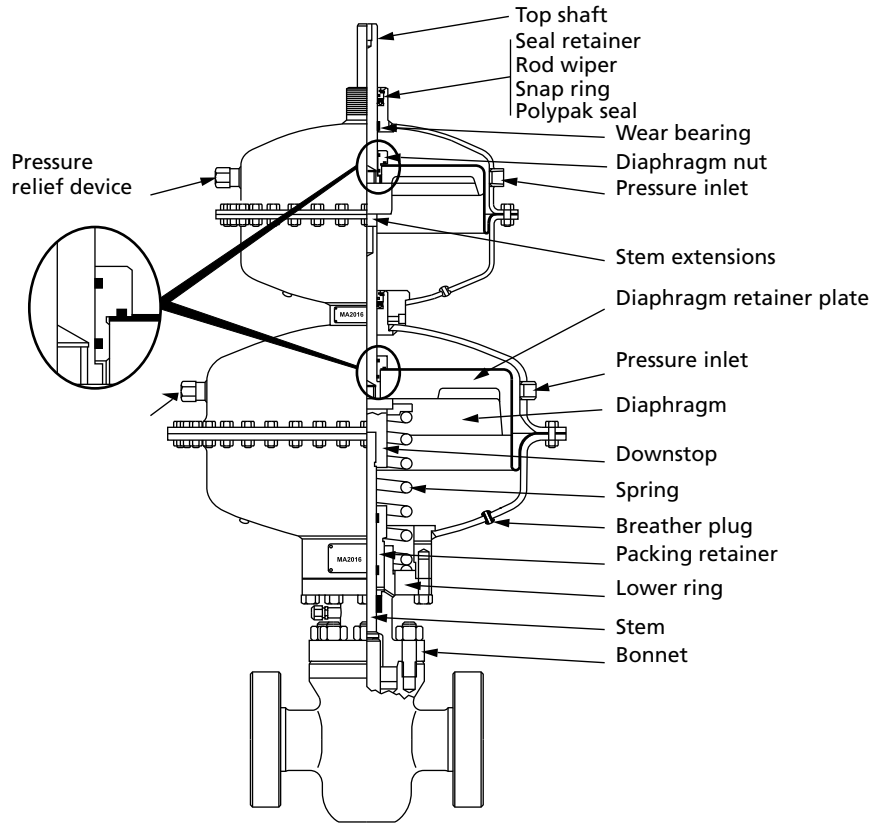

MA 2020 Series

For use with 2", 3", 4", 5", 6" and 8" (50 mm, 80 mm, 100 mm, 125 mm, 150 mm and 200 mm) nominal gate valves (Family Group Code Y55020).

The MA 2020 series increases the area affected by applied control pressure.

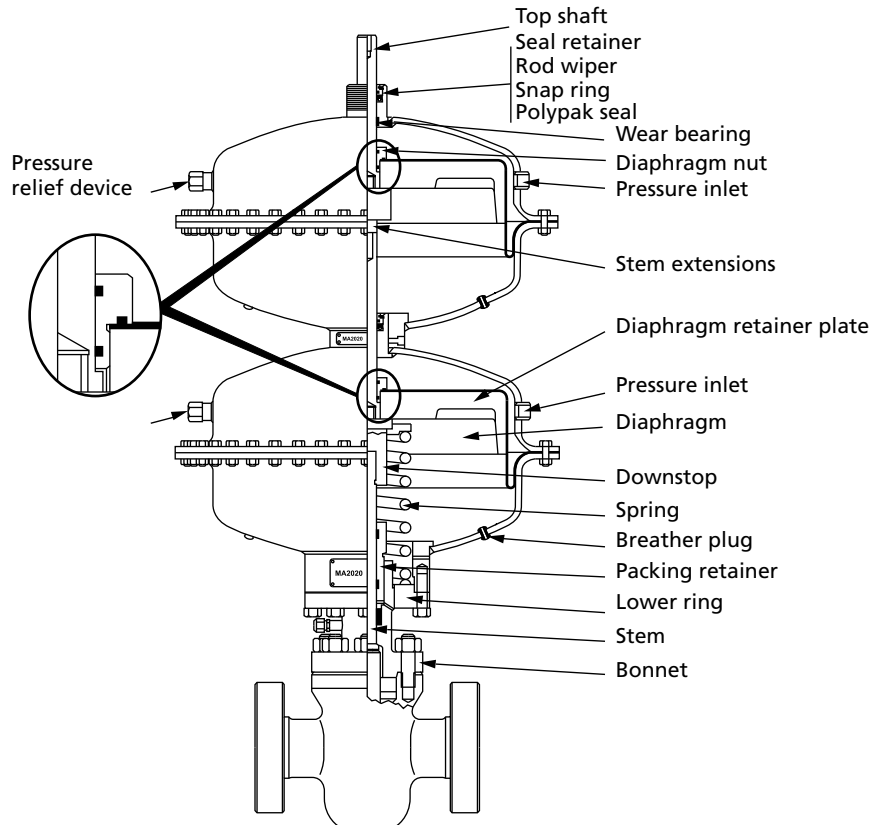

PNEUMATIC PISTON ACTUATOR

MP 13 Series

For use with 2", 3" and 4"
(50 mm, 80 mm and 100 mm)
nominal gate valves
(Family Group Code Y55013).

Description

Cameron's pneumatic piston actuator series is designed for use with all manufacturers' gate valves in nominal sizes of 2" to 4" (50 mm to 100 mm). Its remarkably simple design and operating principle make this piston actuator suitable for a variety of applications. Cameron's piston actuators are interchangeable and very versatile because they operate with many types of supply gas, compressed air, nitrogen or well gas.

Design Advantages

Stronger Actuator Mounting Arrangement

Unlike other designs, the mounting bolts on Cameron's actuators are positioned parallel to the centerline of the actuator, which loads the mounting bolts in tension. This design is not subject to bending and shear forces. This means it can withstand greater separation forces than other actuators on the market.

Corrosion-Resistant Materials

Cameron's piston actuators are manufactured to NACE MR0175. In addition, all non-stainless components are coated with Xylan to increase corrosion resistance.

Superior Diaphragm Design

Cameron's piston actuators utilize a single-piece stainless steel snap ring to facilitate easy cylinder removal. The dynamic piston has a large wear bearing that reduces any internal metal-to-metal contact.

Flexible Actuator Orientation

Connecting misaligned components with rigid tubing can be time-consuming and can induce high stress into the tubing connections. The MA lower ring is threaded to the bonnet, thus allowing rotation of the actuator to accommodate precise alignment.

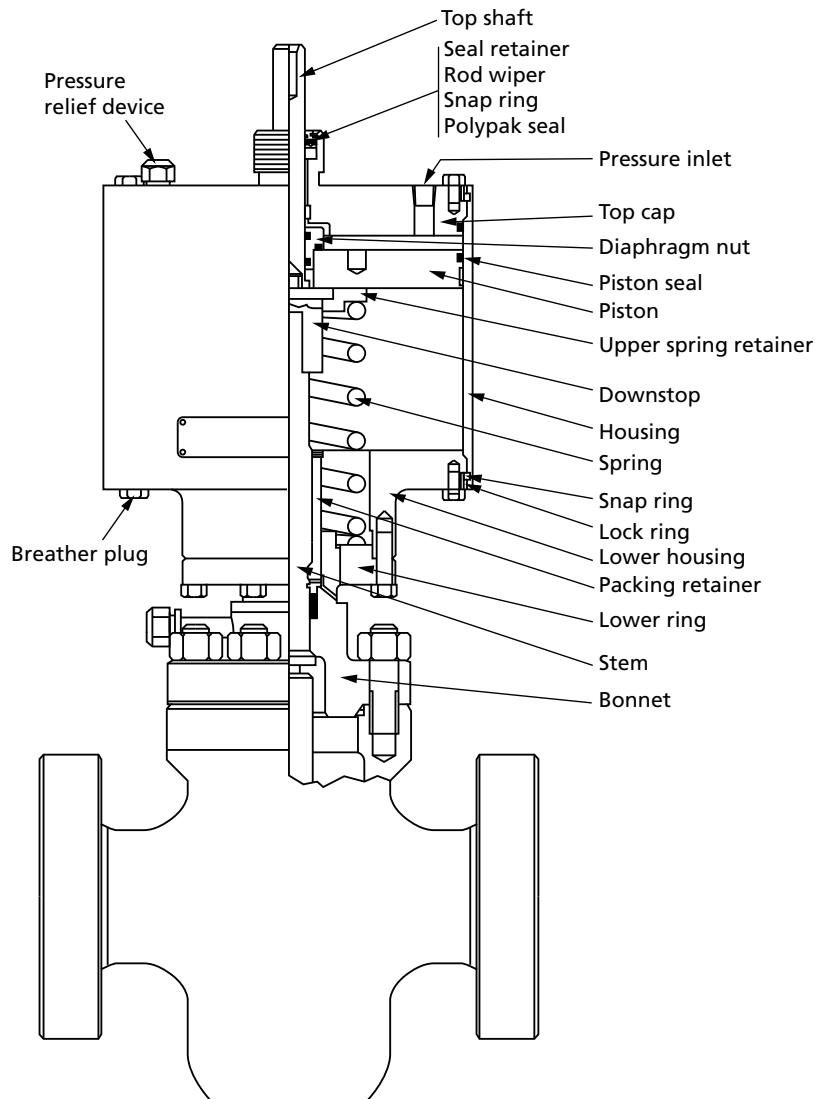

OPERATING SIZE REQUIREMENTS

Model M – 2” to 4” (50 mm to 100 mm) ASME Classes 150 to 1500

Valve Size in. (mm)	ASME Class	ASME Working Pressure (psig)	Stem Thread			Recommended Operating Thrust (lbf)	Recommended Operating Torque (ft-lbf)	Block-and-Bleed Thrust (lbf)	Block-and-Bleed Torque (ft-lbf)	Maximum Allowable Thrust (lbf)	Maximum Allowable Torque (ft-lbf)	Total Stem Travel in. (mm)	Stem Nut Turns-to-Open Valve
			Size in.	Pitch in.	Lead in.								
2 (50)	150	290	0.875	0.167	0.167	457	3	535	4	12,597	93	2.63 (67)	15.8
2 (50)	300	750	0.875	0.167	0.167	1183	9	1383	10	12,597	93	2.63 (67)	15.8
2 (50)	600	1500	0.875	0.167	0.167	2366	17	2766	20	12,597	93	2.63 (67)	15.8
2 (50)	900	2250	0.875	0.167	0.167	3549	26	4149	30	12,597	93	2.63 (67)	15.8
2 (50)	1500	3750	0.875	0.167	0.167	5914	43	6915	51	12,597	93	2.63 (67)	15.8
3 (80)	150	290	1.000	0.200	0.200	803	7	1115	9	16,027	136	4.03 (102)	20.2
3 (80)	300	750	1.000	0.200	0.200	2078	18	2884	25	16,027	136	4.03 (102)	20.2
3 (80)	600	1500	1.000	0.200	0.200	4155	35	5769	49	16,027	136	4.03 (102)	20.2
3 (80)	900	2250	1.000	0.200	0.200	6233	53	8653	74	16,027	136	4.03 (102)	20.2
3 (80)	1500	3750	1.000	0.200	0.200	10,388	88	14,422	123	16,027	136	4.03 (102)	20.2
4 (100)	150	290	1.250	0.250	0.250	1327	14	1783	19	25,442	271	4.88 (124)	19.5
4 (100)	300	750	1.250	0.250	0.250	3432	37	4610	49	25,442	271	4.88 (124)	19.5
4 (100)	600	1500	1.250	0.250	0.250	6864	73	9221	98	25,442	271	4.88 (124)	19.5
4 (100)	900	2250	1.250	0.250	0.250	10,297	110	13,831	147	25,442	271	4.88 (124)	19.5
4 (100)	1500	3750	1.250	0.250	0.250	17,161	183	23,052	245	25,442	271	4.88 (124)	19.5

Model C6B – 6” to 12” (150 mm to 300 mm) ASME Classes 600 to 900

Valve Size in. (mm)	ASME Class	ASME Working Pressure (psig)	Stem Thread			Recommended Operating Thrust (lbf)	Recommended Operating Torque (ft-lbf)	Block-and-Bleed Thrust (lbf)	Block-and-Bleed Torque (ft-lbf)	Maximum Allowable Thrust (lbf)	Maximum Allowable Torque (ft-lbf)	Total Stem Travel in. (mm)	Stem Nut Turns-to-Open Valve
			Size in.	Pitch in.	Lead in.								
6 (150)	600	1500	1.250	0.250	0.250	9839	105	14,307	152	26,783	283	7.25 (184)	29
6 (150)	900	2250	1.250	0.250	0.250	14,758	157	21,460	228	27,685	335	7.25 (184)	29
8 (200)	600	1500	1.750	0.250	0.250	17,099	237	21,507	298	45,807	557	9.25 (235)	37
8 (200)	900	2250	1.750	0.250	0.250	25,649	355	32,261	447	49,637	604	9.25 (235)	37
10 (250)	600	1500	1.750	0.250	0.250	23,859	330	29,078	403	46,726	569	11.25 (286)	45
10 (250)	900	2250	1.750	0.250	0.250	35,789	495	43,617	604	57,297	697	11.25 (286)	45
12 (300)	600	1500	1.750	0.250	0.250	32,032	443	41,381	573	69,033	840	13.31 (338)	53
12 (300)	900	2250	2.000	0.250	0.250	49,816	770	62,072	959	80,522	1109	13.31 (338)	53
14 (350)	150	290	1.500	1.390	0.400	7149	104	16,674	242	9053	131	14.75 (375)	36.875
14 (350)	600	1500	2.000	1.864	0.500	39,183	741	64,831	1226	46,824	886	14.75 (375)	29.50
16 (400)	150	290	1.500	1.390	0.400	9177	133	27,543	399	11,448	166	16.75 (425)	41.875
16 (400)	600	1500	2.000	1.864	0.500	49,676	940	69,091	1307	59,215	1120	16.75 (425)	33.50
18 (450)	150	290	1.500	1.390	0.400	11,594	168	22,596	327	13,960	202	18.50 (470)	46.25
18 (450)	600	1500	2.250	2.113	0.500	63,501	1303	98,175	2014	72,208	1481	18.75 (470)	37.50
20 (500)	150	290	1.750	1.614	0.500	14,380	249	31,621	548	17,230	298	20.75 (527)	41.50
20 (500)	600	1500	2.750	2.536	0.500	79,986	1858	145,272	3375	89,122	2070	20.75 (527)	41.50
24 (600)	150	290	2.000	1.864	0.500	20,606	390	21,390	405	26,347	498	25.125 (638)	50.25
24 (600)	600	1500	3.250	3.036	0.800	114,674	3510	219,495	6718	136,279	4171	25.00 (635)	31.25

- Note:
1. Recommended operating thrust and torque are the loads required to open or close the valve with full differential pressure across the gate. The operator should be sized for these values.
 2. Maximum allowable thrust and torque values are maximum allowable loads of the valve.
 3. When block-and-bleed or double block-and-bleed service is specified, operators should be sized for these values.
 4. Unless otherwise stated, handwheel rim pull for manual and motor operators shall not exceed 120 lb (54 kg).
 5. All torque and thrust values are based on maximum working pressure at ambient temperature.

Models C6, C2B, C2C – 6" to 36" (150 mm to 900 mm) ASME Classes 150 to 900

Valve Size in. (mm)	ASME Class	ASME Working Pressure (psig)	Stem Thread			Recommended Operating Thrust (lbf)	Recommended Operating Torque (ft-lbf)	Maximum Allowable Thrust (lbf)	Maximum Allowable Torque (ft-lbf)	Block-and-Bleed Thrust (lbf)	Block-and-Bleed Torque (ft-lbf)	Total Stem Travel in. (mm)	Stem Nut Turns-to-Open Valve
			Size in.	Pitch in.	Lead in.								
6 (150)	150	290	1.250	0.250	0.250	1902	18	31,785	307	2762	27	7.25 (184)	29
6 (150)	300	750	1.250	0.250	0.250	4919	47	31,785	307	7143	69	7.25 (184)	29
6 (150)	600	1500	1.250	0.250	0.250	9836	95	31,785	307	14,285	138	7.25 (184)	29
6 (150)	900	2250	1.250	0.250	0.250	14,757	142	31,785	307	21,428	207	7.25 (184)	29
8 (200)	150	290	1.500	0.250	0.250	3106	34	52,036	574	4153	46	9.25 (235)	37
8 (200)	300	750	1.500	0.250	0.250	8033	89	52,036	574	10,740	119	9.25 (235)	37
8 (200)	600	1500	1.500	0.250	0.250	16,067	177	52,036	574	21,481	237	9.25 (235)	37
8 (200)	900	2250	1.500	0.250	0.250	24,100	266	52,036	574	32,221	356	9.25 (235)	37
10 (250)	150	290	1.500	0.250	0.250	4413	49	52,036	574	5817	64	11.25 (286)	45
10 (250)	300	750	1.500	0.250	0.250	11,413	126	52,036	574	15,045	168	11.25 (286)	45
10 (250)	600	1500	1.500	0.250	0.250	22,828	252	52,036	574	30,090	332	11.25 (286)	45
10 (250)	900	2250	1.500	0.250	0.250	34,239	378	52,036	574	45,135	498	11.25 (286)	45
12 (300)	150	290	1.500	0.250	0.250	5993	66	52,036	574	7755	86	13.25 (337)	53
12 (300)	300	750	1.500	0.250	0.250	15,500	171	52,036	574	20,056	221	13.25 (337)	53
12 (300)	600	1500	1.500	0.250	0.250	30,999	342	52,036	574	40,113	443	13.25 (337)	53
12 (300)	900	2250	1.750	0.250	0.250	48,045	597	77,223	960	60,169	748	13.25 (337)	53
14 (350)	150	290	1.500	0.200	0.400	7149	95	54,521	722	9063	120	14.69 (373)	36.73
14 (350)	300	750	2.000	0.250	0.500	19,594	338	101,611	1754	23,439	405	14.69 (373)	29.38
14 (350)	600	1500	2.000	0.250	0.500	39,187	676	101,611	1754	46,878	809	14.69 (373)	29.38
14 (350)	900	2250	2.250	0.250	0.500	60,540	1129	135,875	2533	70,547	1315	14.69 (373)	29.38
16 (400)	150	290	1.500	0.200	0.400	9178	122	54,521	722	11,439	152	16.69 (424)	41.73
16 (400)	300	750	1.500	0.200	0.400	23,735	314	54,521	722	29,584	392	16.69 (424)	41.73
16 (400)	600	1500	2.000	0.250	0.500	49,680	857	101,611	1754	59,168	1021	16.69 (424)	33.38
16 (400)	900	2250	2.750	0.400	0.800	81,146	2040	180,794	4546	88,752	2232	16.69 (424)	20.86
18 (450)	150	290	1.500	0.200	0.400	11,594	154	54,521	722	13,974	185	18.44 (468)	46.10
18 (450)	300	750	1.750	0.250	0.500	30,500	484	72,304	1148	36,139	574	18.69 (475)	37.38
18 (450)	600	1500	2.250	0.250	0.500	63,504	1184	135,875	2533	72,278	1347	18.69 (475)	37.38
18 (450)	900	2250	2.750	0.400	0.800	99,884	2512	180,794	4546	108,418	2726	18.69 (475)	23.36
20 (500)	150	290	1.750	0.250	0.500	14,381	228	72,304	1148	17,245	274	20.75 (527)	41.50
20 (500)	300	750	2.000	0.250	0.500	37,782	652	101,611	1754	44,600	770	20.75 (527)	41.50
20 (500)	600	1500	2.750	0.400	0.800	79,982	2011	180,794	4546	89,200	2243	20.75 (527)	25.94
20 (500)	900	2250	3.000	0.400	0.800	122,624	3252	225,696	5986	133,801	3549	20.75 (527)	25.94
22 (550)	150	290	1.750	0.250	0.500	17,243	274	72,304	1148	21,470	341	22.94 (583)	45.88
22 (550)	300	750	2.250	0.250	0.500	45,845	855	135,875	2533	55,526	1035	22.94 (583)	45.88
22 (550)	600	1500	3.000	0.400	0.800	96,549	2561	225,696	5986	111,051	2945	22.94 (583)	28.68
24 (600)	150	290	2.000	0.250	0.500	20,605	356	101,611	1754	26,366	455	25.13 (638)	50.26
24 (600)	300	750	2.250	0.250	0.500	53,952	1006	135,875	2533	68,188	1271	25.13 (638)	50.26
24 (600)	600	1500	3.250	0.400	0.800	114,677	3200	275,560	7689	138,375	3806	25.13 (638)	31.41
24 (600)	900	2250	3.750	0.400	0.800	178,422	5474	390,393	11,977	204,563	6276	25.13 (638)	31.41
30 (750)	150	290	2.250	0.250	0.500	31,396	585	135,875	2533	42,018	783	31.25 (794)	62.50
30 (750)	300	750	3.000	0.400	0.800	83,626	2218	225,698	5986	108,866	2882	31.25 (794)	39.06
30 (750)	600	1500	3.750	0.400	0.800	173,437	5321	390,393	11,877	217,333	6668	31.25 (794)	39.06
36 (900)	150	290	2.750	0.400	0.800	44,184	1111	180,794	4546	57,303	1441	36.88 (937)	46.10
36 (900)	300	750	3.250	0.400	0.800	116,110	3240	275,560	7889	148,199	4135	36.88 (937)	46.10
36 (900)	600	1500	4.250	0.400	0.800	241,350	8075	525,088	17,568	296,397	9317	36.88 (937)	46.10

- Note:
1. Use recommended operating thrust and torque for sizing bevel gear operators.
 2. Use block-and-bleed thrust and torque for sizing power operators (electric, gas, hydraulic and more).
 3. Maximum operating thrust and torque are the maximum allowable for the valve.

TOPWORKS

Model M

Sizes 2" to 4" (50 mm to 100 mm)

Classes 150, 600, 900 and 1500

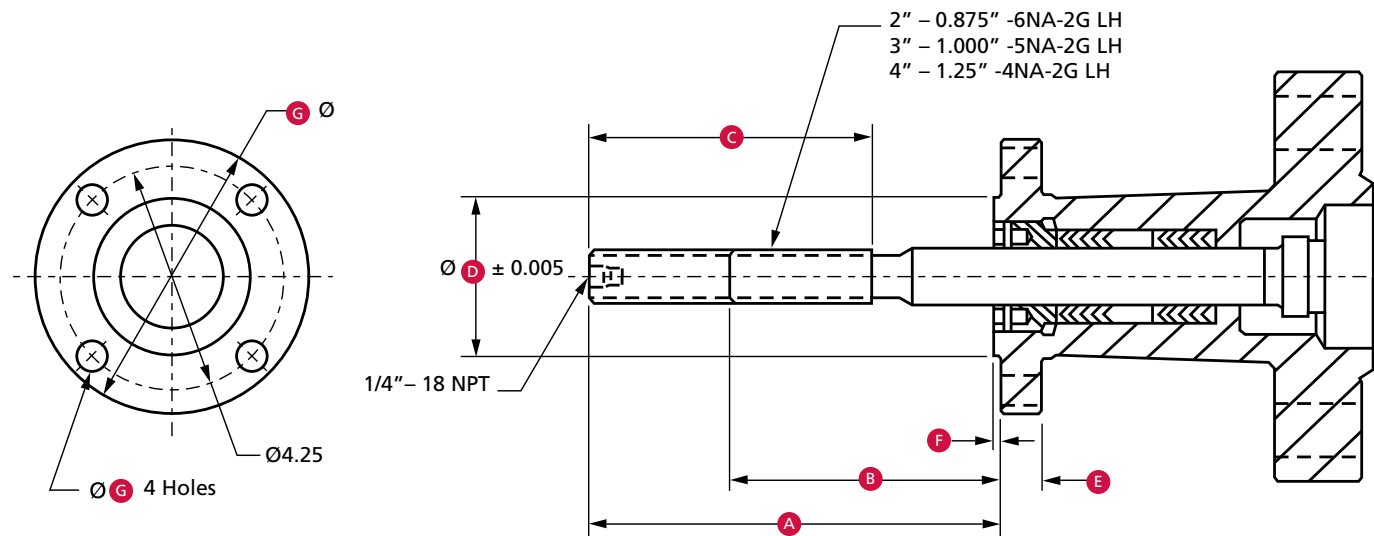

Model M

Size in. (mm)	ASME Class	Open A	Closed							
			B	C	D	E	F	G	H	J
2 (50)	600 and 1500	9.25 (234.95)	6.56 (166.62)	6.44 (163.58)	2.808 (71.32)	0.63 (16.00)	0.12 (3.05)	5.00 (127.00)	4.00 (101.60)	4 (101.60)
3 (80)	150 and 1500	12.00 (304.80)	7.97 (202.44)	7.75 (196.85)	2.808 (71.32)	0.63 (16.00)	0.12 (3.05)	5.00 (127.00)	4.00 (101.60)	4 (101.60)
4 (100)	150 and 600	15.00 (381.00)	10.12 (257.05)	9.95 (252.73)	3.308 (84.02)	0.625 (15.88)	0.12 (3.05)	5.25 (133.35)	4.25 (107.95)	4 (101.60)
4 (100)	900 and 1500	13.63 (346.20)	8.75 (222.25)	9.95 (252.73)	3.308 (84.02)	1.00 (25.40)	0.12 (3.05)	6.00 (152.40)	5.00 (127.00)	4 (101.60)

TOPWORKS

Model C6

Sizes 6" to 12" (150 mm to 300 mm)

Class 150

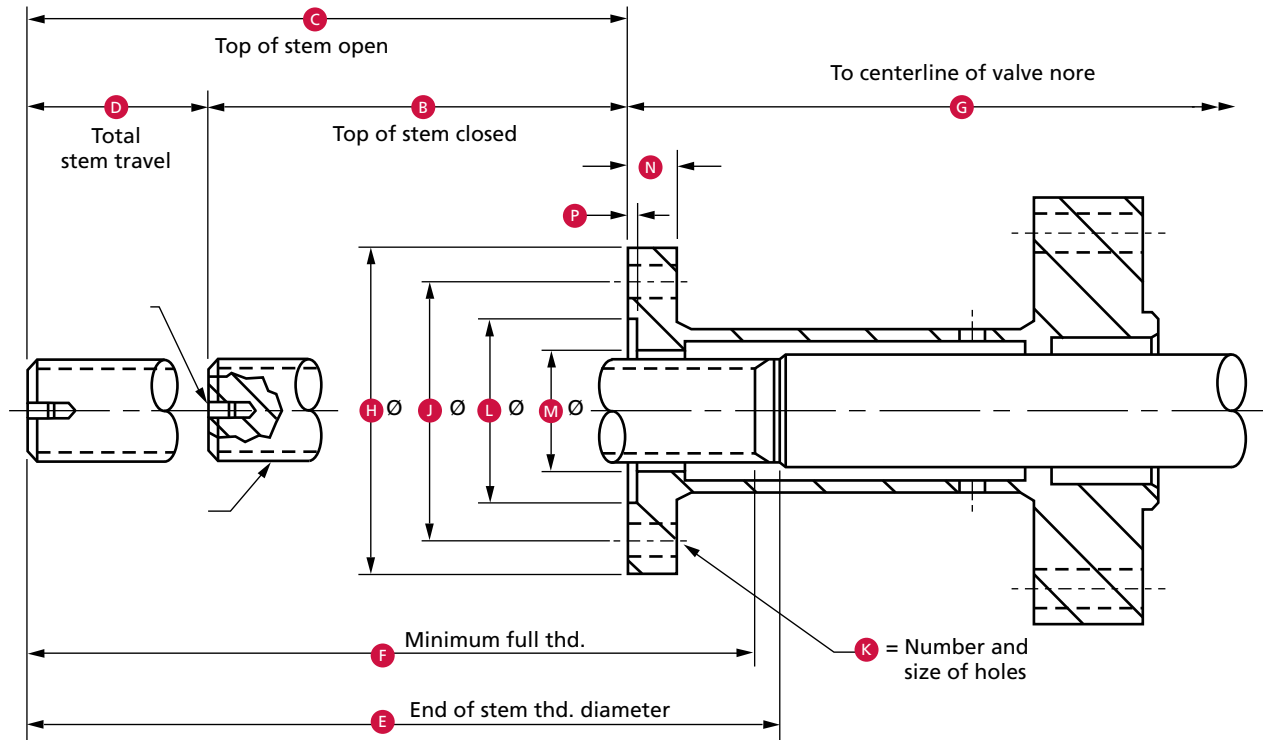

Model C6

Size in. (mm)	Series	ISO FLG	A -NA-2G-L.H. Single Lead Thd.	Closed		Open										
				B	C	D	E	F	G	H	J	K	L	M	N	P
6 (150)	150/3C	F14	1-1/2 - 0.250P - 0.250L	8.50 (215.90)	15.75 (400.05)	7.25 (184.15)	16.83 (427.48)	16.31 (414.27)	27.38 (695.45)	6.88 (174.75)	5.50 (139.70)	4 - 0.658 (4 - 16.71)	3.942 (100.127) 3.952 (100.381)	2.62 (66.55)	1.00 (25.40)	0.169 (4.29) 0.183 (4.65)
8 (200)	150/3C	F14	1-1/2 - 0.250P - 0.250L	10.19 (258.83)	19.44 (493.78)	9.25 (234.95)	20.58 (522.73)	20.06 (509.52)	35.44 (900.18)	6.88 (174.75)	5.50 (139.70)	4 - 0.688 (4 - 17.48)	3.942 (100.127) 3.952 (100.381)	2.62 (66.55)	1.00 (25.40)	0.169 (4.29) 0.183 (4.65)
10 (350)	150/3C	F14	1-1/2 - 0.250P - 0.250L	8.19 (208.03)	19.44 (493.78)	11.25 (285.75)	20.58 (522.73)	20.06 (509.52)	38.50 (977.90)	6.88 (174.75)	5.50 (139.70)	4 - 0.688 (4 - 17.48)	3.942 (100.127) 3.952 (100.381)	2.62 (66.55)	1.00 (25.40)	0.169 (4.29) 0.183 (4.65)
12 (300)	150/3C	F14	1-1/2 - 0.250P - 0.250L	9.69 (246.13)	23.00 (584.20)	13.31 (338.07)	24.20 (614.68)	23.69 (601.73)	44.00 (1117.60)	6.88 (174.75)	5.50 (139.70)	4 - 0.688 (4 - 17.48)	3.942 (100.127) 3.952 (100.381)	2.62 (66.55)	1.00 (25.40)	0.169 (4.29) 0.183 (4.65)

TOPWORKS

Model C6B

Sizes 6" to 12" (150 mm to 600 mm)

Classes 150, 600 and 900

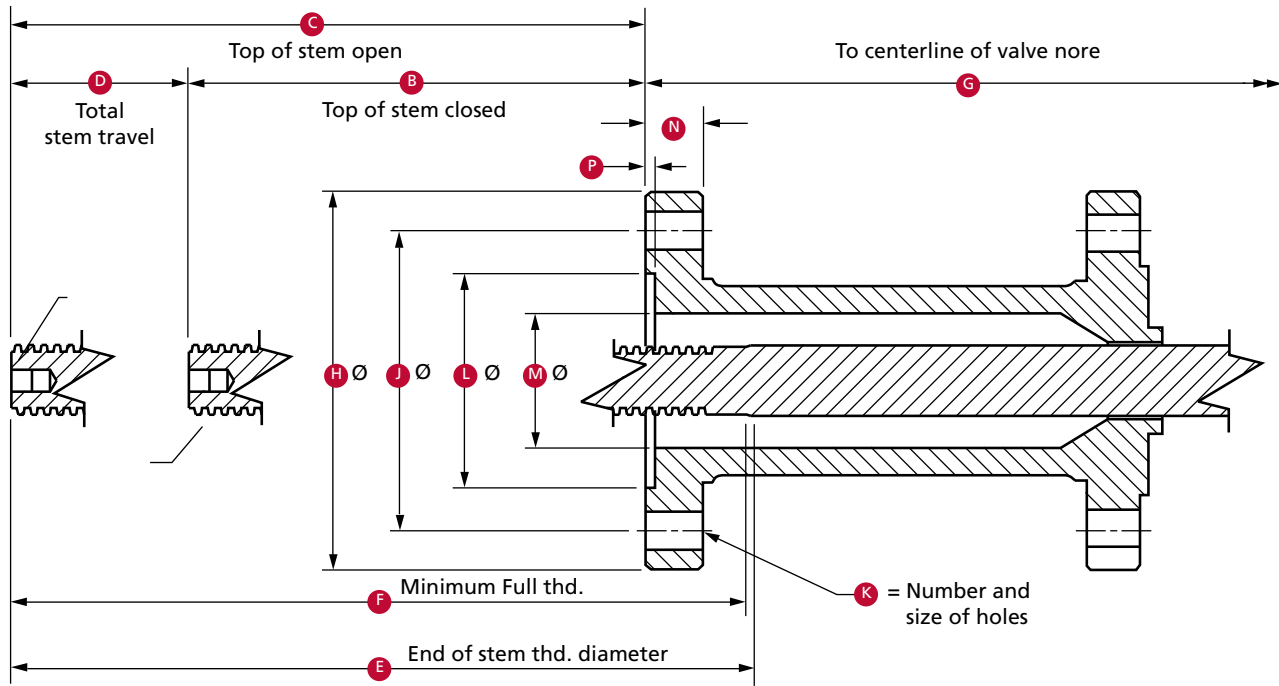

Model C6B

Size in. (mm)	Class	ISO FLG	ACME Stem A	Closed B	Open C	D	E	F	G	H	J	K	L	M	N	P
6 (150)	600 and 900	F14	1-1/4 - 0.250P - 0.250L	7.83 (198.88)	10.02 (254.51)	7.19 (182.63)	16.69 (423.93)	16.25 (412.75)	28.06 (712.72)	6.89 (175.01)	5.512 (140.00)	4 - 0.688 (4 - 17.48)	3.945 (100.203)	2.50 (63.50)	1.03 (26.16)	0.168 (4.267)
													3.955 (100.457)			0.188 (4.775)
8 (200)	600 and 900	F14	1-3/4 - 0.250P - 0.250L	10.17 (258.32)	19.37 (492.00)	9.20 (233.68)	20.44 (519.18)	20.00 (508.00)	35.41 (899.41)	6.89 (175.01)	5.512 (140.00)	4 - 0.688 (4 - 17.48)	3.945 (100.203)	2.50 (63.50)	1.03 (26.16)	0.168 (4.267)
													3.955 (100.457)			0.188 (4.775)
10 (250)	600	F14	1-3/4 - 0.250P - 0.250L	8.17 (207.52)	19.37 (492.00)	11.20 (284.48)	20.44 (519.18)	20.00 (508.00)	38.47 (977.14)	6.89 (175.01)	5.512 (140.00)	4 - 0.688 (4 - 17.48)	3.945 (100.203)	2.50 (63.50)	1.03 (26.16)	0.168 (4.267)
													3.955 (100.457)			0.188 (4.775)
10 (250)	900	F16	1-3/4 - 0.250P - 0.250L	8.17 (207.52)	19.37 (492.00)	11.20 (284.48)	20.44 (519.18)	20.00 (508.00)	38.47 (977.14)	8.27 (210.06)	6.496 (165.00)	4 - 0.812 (4 - 20.62)	5.240 (133.096)	2.50 (63.50)	1.50 (38.10)	0.220 (5.588)
													5.260 (133.604)			0.240 (6.096)
12 (300)	600	F16	1-3/4 - 0.250P - 0.250L	9.61 (244.09)	22.83 (579.88)	13.22 (335.79)	24.06 (611.12)	23.62 (599.95)	43.91 (1115.31)	8.27 (210.06)	6.496 (165.00)	4 - 0.812 (4 - 20.62)	5.240 (133.096)	2.50 (63.50)	1.50 (38.10)	0.220 (5.588)
													5.260 (133.604)			0.240 (6.096)
12 (300)	900	F16	2 - 0.250P - 0.250L	9.55 (242.57)	22.67 (575.82)	13.12 (333.25)	24.06 (611.12)	23.62 (599.95)	44.47 (1129.54)	8.27 (210.06)	6.496 (165.00)	4 - 0.812 (4 - 20.62)	5.240 (133.096)	3.25 (82.55)	1.50 (38.10)	0.220 (5.588)
													5.260 (133.604)			0.240 (6.096)
14 (350)	150	FA14	1-1/2 - 0.200P - 0.400L	10.68 (271.27)	25.34 (643.64)	14.66 (372.36)	26.39 (670.31)	25.69 (652.53)	46.50 (1181.10)	6.89 (175.01)	5.512 (140.00)	4 - 0.688 (4 - 17.48)	3.945 (100.203)	2.50 (63.50)	1.03 (26.16)	0.168 (4.267)
													3.955 (100.457)			0.188 (4.775)
14 (350)	600	FA16	2 - 0.250P - 0.500L	10.68 (271.27)	25.34 (643.64)	14.66 (372.36)	27.27 (692.66)	26.69 (677.93)	49.75 (1263.65)	8.25 (209.55)	6.500 (165.10)	4 - 0.812 (4 - 20.62)	5.010 (127.254)	2.88 (73.15)	1.50 (38.10)	0.220 (5.588)
													5.020 (127.508)			0.240 (6.096)
16 (400)	150	FA14	1-1/2 - 0.200P - 0.400L	10.38 (263.65)	27.07 (687.58)	16.69 (423.93)	28.14 (714.76)	27.56 (700.02)	51.37 (1304.80)	6.89 (175.01)	5.512 (140.00)	4 - 0.688 (4 - 17.48)	3.945 (100.203)	2.50 (63.50)	1.03 (26.16)	0.168 (4.267)
													3.955 (100.457)			0.188 (4.775)
16 (400)	600	FA25	2 - 0.250P - 0.500L	10.19 (258.83)	28.86 (733.04)	16.67 (423.42)	28.20 (716.28)	27.59 (700.79)	53.56 (1360.42)	11.50 (292.10)	10.000 (254.00)	8 - 0.688 (8 - 17.48)	6.010 (152.654)	3.12 (79.25)	2.00 (50.80)	0.220 (5.588)
													6.020 (152.908)			0.240 (6.096)
18 (450)	150	FA14	1-1/2 - 0.200P - 0.400L	11.68 (296.67)	30.09 (764.29)	18.41 (467.61)	31.14 (790.96)	27.56 (700.02)	57.00 (1447.80)	6.89 (175.01)	5.512 (140.00)	4 - 0.688 (4 - 17.48)	3.945 (100.203)	2.50 (63.50)	1.03 (26.16)	0.168 (4.267)
													3.955 (100.457)			0.188 (4.775)
18 (450)	600	FA25	2-1/4 - 0.250P - 0.500L	11.93 (303.02)	30.62 (777.75)	18.69 (474.73)	32.39 (822.71)	31.81 (807.97)	60.19 (1528.83)	11.50 (292.10)	10.000 (254.00)	8 - 0.688 (8 - 17.48)	6.010 (152.654)	3.00 (76.20)	2.36 (59.94)	0.220 (5.588)
													6.020 (152.908)			0.240 (6.096)
20 (500)	150	FA14	1-3/4 - 0.250P - 0.500L	10.97 (278.64)	31.69 (804.93)	20.72 (526.29)	32.83 (833.88)	32.25 (819.15)	62.28 (1581.91)	6.89 (175.01)	5.512 (140.00)	4 - 0.688 (4 - 17.48)	3.945 (100.203)	2.50 (63.50)	1.03 (26.16)	0.168 (4.267)
													3.955 (100.457)			0.188 (4.775)
20 (500)	600	FA30	2-3/4 - 0.400P - 0.800L	12.57 (319.28)	33.30 (845.82)	20.73 (526.54)	34.88 (885.95)	34.31 (872.24)	65.67 (1668.02)	13.62 (345.95)	11.750 (298.45)	8 - 0.875 (8 - 22.23)	7.010 (178.054)	3.50 (89.90)	2.75 (69.85)	0.220 (5.588)
													7.020 (178.308)			0.240 (6.096)
24 (600)	150	FA14	2 - 0.250P - 0.500L	11.03 (280.16)	36.14 (917.96)	25.11 (637.79)	37.02 (940.31)	36.44 (925.58)	75.61 (1920.49)	6.89 (175.01)	5.512 (140.00)	4 - 0.688 (4 - 17.48)	3.945 (100.203)	2.50 (63.50)	1.03 (26.16)	0.168 (4.267)
													3.955 (100.457)			0.188 (4.775)
24 (600)	600	FA35	3-1/4 - 0.400P - 0.800L	13.12 (333.25)	38.26 (971.80)	25.14 (638.56)	39.95 (1014.73)	39.38 (1000.25)	80.00 (2032.00)	16.12 (409.45)	14.000 (355.60)	8 - 1.120 (8 - 28.45)	8.510 (216.154)	4.50 (114.30)	3.00 (76.20)	0.223 (5.664)
													8.520 (216.408)			0.237 (6.020)

FLOW COEFFICIENTS (C_v)

The following chart outlines the C_v for through-conduit gate valves having end-to-end dimensions and bore diameters in compliance with API 6D standards.

C_v is the flow of water through the valve at 1 psi pressure drop in gal/min. Since C_v is a calculated number, the actual value may vary.

Valve Size in. (mm)	150	300	400	600	900	1500	2500
2 (50)	476	432	378	378	337	337	218
3 x 2 (80 x 50)	-	-	165	165	203	239	-
2-1/2 (65)	-	-	682	682	558	558	305
3 (80)	1358	1155	1053	1109	1072	966	474
4 x 3 (100 x 80)	-	-	534	529	597	677	624
4 (100)	2508	2176	1925	1944	1890	1730	725
6 x 4 (150 x 100)	-	-	886	944	943	1231	-
6 (150)	5402	5300	4860	4577	4383	3622	2510
8 x 6 (200 x 150)	2583	2499	-	3240	3588	2137	-
8 (200)	11,261	11,054	9345	8886	8416	6879	5227
10 x 8 (250 x 200)	-	5218	-	5036	7975	4859	-
12 x 8 (300 x 200)	-	3302	-	3892	-	-	-
10 (250)	19,181	18,856	15,771	14,533	14,087	11,283	8313
12 (300)	29,435	28,980	23,834	22,729	21,025	16,843	12,282
12 x 10 (300 x 250)	7875	-	-	12,799	7299	-	-
14 (350)	35,605	30,883	29,921	28,837	23,846	20,336	-
16 x 14 (400 x 350)	-	-	-	21,096	-	-	-
16 (400)	49,979	42,224	41,022	39,144	33,358	27,548	21,396
20 x 16 (500 x 400)	13,060	-	15,761	-	-	-	-
18 (450)	66,156	55,740	54,277	51,368	45,004	-	-
20 (500)	83,865	70,386	68,680	64,559	56,871	-	-
22 (550)	-	86,869	85,422	80,279	-	-	-
24 (600)	127,916	106,835	103,504	97,240	84,836	-	-
26 (650)	149,428	123,222	120,829	114,905	-	-	-
28 (700)	176,798	144,355	142,391	135,267	-	-	-
30 (750)	212,313	170,229	163,776	157,401	133,706	-	-
36 (900)	322,548	245,362	236,147	224,424	-	-	-

FLOW COEFFICIENTS (K_v)

The following chart outlines the K_v for through-conduit gate valves having end-to-end dimensions and bore diameters in compliance with API 6D.

K_v is the flow of water through the valve at 1 bar pressure drop in cu m/hr. Since K_v is a calculated number, the actual value may vary.

Valve Size in. (mm)	150	300	400	600	900	1500	2500
2 (50)	412	373	327	327	291	291	188
3 x 2 (80 x 50)	-	-	142	142	175	207	-
2-1/2 (65)	-	-	590	590	483	483	264
3 (80)	1175	999	911	959	927	835	410
4 x 3 (100 x 80)	-	-	462	458	516	585	540
4 (100)	2170	1882	1665	1682	1635	1496	627
6 x 4 (150 x 100)	-	-	766	817	816	1065	-
6 (150)	4673	4585	4204	3959	3792	3133	2172
8 x 6 (200 x 150)	2234	2162	-	2803	3103	1849	-
8 (200)	9742	9562	8084	7687	7280	5951	4522
10 x 8 (250 x 200)	-	4514	-	4356	6898	4204	-
12 x 8 (300 x 200)	-	2857	-	3367	-	-	-
10 (250)	16,592	16,312	13,643	12,572	12,186	9761	7191
12 (300)	25,463	25,070	20,617	19,662	18,188	14,570	10,624
12 x 10 (300 x 250)	6812	-	-	11,072	6314	-	-
14 (350)	30,800	26,715	25,883	24,945	20,628	17,591	-
16 x 14 (400 x 350)	-	-	-	18,249	-	-	-
16 (400)	43,234	36,526	35,486	33,862	28,856	23,831	18,509
20 x 16 (500 x 400)	11,298	-	13,634	-	-	-	-
18 (450)	57,228	48,218	46,953	44,436	38,930	-	-
20 (500)	72,547	60,888	59,412	55,847	49,196	-	-
22 (550)	-	75,147	73,894	69,445	-	-	-
24 (600)	110,654	92,417	89,536	84,117	73,388	-	-
26 (650)	129,263	106,593	104,523	99,399	-	-	-
28 (700)	152,939	124,874	123,175	117,013	-	-	-
30 (750)	183,661	147,257	141,674	136,160	115,662	-	-
36 (900)	279,021	212,251	204,279	194,138	-	-	-

TRIM CHART

Service	Trim Code	Body and Bonnet	Gate	Seat	Stem Seal	Stem	Bolting	Fittings	Temperature Range
Waterflood, Corrosive	T-10	WCC Carbon Steel, Internally Coated	Carbon Steel, ASME Classes 300-600, Low-Alloy Steel 900 Class, Nickel-Plated	Carbon Steel, Nickel-Plated PTFE Insert	PTFE	Low-Alloy Steel, Nickel-Plated	Alloy Steel, NACE	Stainless Steel	-20° F to 250° F (-29° C to 121° C)
Standard	T-11 2" to 4" only	WCC Carbon Steel	Carbon Steel, Low-Alloy Steel, Nickel-Plated	Carbon Steel, Nickel-Plated PTFE Insert	FKM Viton	Low-Alloy Steel, Nickel-Plated	Alloy Steel	Carbon Steel	-20° F to 250° F (-29° C to 121° C)
Corrosive Service	T-22	WCC Carbon Steel	410 Stainless Steel	410 Stainless Steel	PTFE	17-4 PH Stainless Steel	Alloy Steel	Stainless Steel	-20° F to 250° F (-29° C to 121° C)
Sour, Mildly Corrosive	T-24 2" and larger	WCC Carbon Steel	Carbon Steel, ASME Classes 300-600, Low-Alloy Steel 900 Class, Nickel-Plated	Carbon Steel, Nickel-Plated PTFE Insert	PTFE	Low-Alloy Steel, Nickel-Plated	Alloy Steel, NACE	Stainless Steel	-20° F to 250° F (-29° C to 121° C)
Low-Temperature, Non-Sour	T-36	LCC Carbon Steel, Impact-Tested	Carbon Steel, ASME Classes 300-600, Low-Alloy Steel 900 Class, Nickel-Plated	Carbon Steel, Nickel-Plated PTFE Insert	PTFE	Low-Alloy Steel, Impact-Tested, Nickel-Plated	Alloy Steel, Impact-Tested	Stainless Steel	-50° F to 250° F (-46° C to 121° C)
Low-Temperature, Sour	T-37	LCC Carbon Steel, Impact-Tested	Carbon Steel, ASME Classes 300-600, Low-Alloy Steel 900 Class, Nickel-Plated	Carbon Steel, Nickel-Plated PTFE Insert	PTFE	Low-Alloy Steel, Impact-Tested, Nickel-Plated	Alloy Steel, NACE, Impact-Tested	Stainless Steel	-50° F to 250° F (-46° C to 121° C)
Anhydrous Ammonia	T-88	WCC/A36 Carbon Steel	Carbon Steel, Low-Alloy Steel, Nickel-Plated	Carbon Steel, Nickel-Plated PTFE Insert	PTFE	Low-Alloy Steel, Nickel-Plated	Alloy Steel, NACE	Stainless Steel	-20° F to 250° F (-29° C to 121° C)
Standard	T-94	WCC Carbon Steel	Carbon Steel, ASME Classes 300-600, Low-Alloy Steel 900 Class, Nickel-Plated	Carbon Steel, Nickel-Plated PTFE Insert	Special	Low-Alloy Steel, Nickel-Plated	Alloy Steel	Carbon Steel	-20° F to 350° F (-29° C to 177° C)
MTBE	T-102 6" and larger	WCC Carbon Steel	Carbon Steel, ASME Classes 300-600, Low-Alloy Steel 900 Class, Nickel-Plated	Carbon Steel, Nickel-Plated PTFE Insert	PTFE	Low-Alloy Steel, Nickel-Plated	Alloy Steel	Carbon Steel	-20° F to 250° F (-29° C to 121° C)
Standard	T-101 6" and larger	WCC Carbon Steel	Carbon Steel, ASME Classes 300-600, Low-Alloy Steel 900 Class, Nickel-Plated	Carbon Steel, Nickel-Plated PTFE Insert	PTFE	Low-Alloy Steel, Nickel-Plated	Alloy Steel	Carbon Steel	-20° F to 250° F (-29° C to 121° C)

COMMON TRIMS

Waterflood (T-10) – Carbon steel body/bonnet with wetted surface, ENP-plated, internal parts of corrosion-resistant materials.

Model M (Sizes 2" to 4", (50 mm to 100 mm), Classes 600 through 1500) Standard (T-11) – For non-corrosive aromatic service with concentration of MTBE to 100%.

Corrosive Service – Internal Parts (T-22) – For substantially the same service as T-21, but where the corrosion resistance of internal parts is desirable. The valve internal sealing members are stainless steel to gain this corrosion resistance. This trim also is usable for mildly corrosive fluids and gases when limited corrosion of the internal body surfaces can be tolerated.

Sour Gas and Oil (NACE MR0175) (T-24) – Primarily for sour gas and oil (NACE MR0175) where resistance to H₂S embrittlement is required. Also suitable for other chemicals, products or hydrocarbons when H₂S is present. May be used when CO₂ is present in smaller amounts than H₂S.

Low-Temperature - 50° F (-46° C) NACE (T-36) – For essentially non-corrosive ladings, either liquid or gaseous. The pressure-retaining components (body, bonnet and bolting) are of impact-tested materials.

Low-Temperature Sour -50° F (-46° C) NACE (T-37) – Primarily for sour gas and oil (NACE MR0175) where resistance to H₂S embrittlement is required at -50° F (-46° C) service. The pressure-retaining components (body, bonnet and bolting) are of impact-tested materials. Also suitable for other chemicals, products or hydrocarbons when H₂S is present. Can be used when CO₂ is present in smaller amounts than H₂S.

Anhydrous Ammonia (T-88) – Special elastomers and stem nut for ammonia service

Fire-Tested to API 6FA (T-94) – These valves have been qualified as fire-tested and contain a special stem packing arrangement for essentially non-corrosive ladings. The elastomer O-rings used for seal and bonnet seals are of a material that will not swell and affect the operation of the valve. Typical examples of ladings are: gasoline, benzene, toluene, carbon-tetrachloride, 1,1, 1 trichloroethane, richloroethylene perchloroethylene and phosphate ester hydraulic fluids.

Aromatic (to 40% MTBE, Fire-Tested API 6FA or ISO 10497) (T-101) – For essentially non-corrosive, non-sour aromatic or non-aromatic service with methanol or ethanol based corrosion inhibitors where up to 40% MTBE may be present.

PARTIAL OPEN FLOW CHARACTERISTICS

The following graph approximates the flow coefficient, C_v or K_v , of gate valves as a function of the valve stroke going from closed to open. Note that this is an estimation only because of assumptions made in the valve stroke, as well as unpredictable flow characteristics around the gate-seat bore in the partially open position.

Gate valves are intended for on-off service. Intermittent throttling such as pressure equalization service is acceptable. Continuous throttling is not recommended. This information is provided only to facilitate the engineering of systems in the transition between open and closed positions of the valves. One example might be to evaluate the possibility of water hammer in liquid pipelines.

Partial Open Flow Characteristics (Through Conduit Gate Valves)

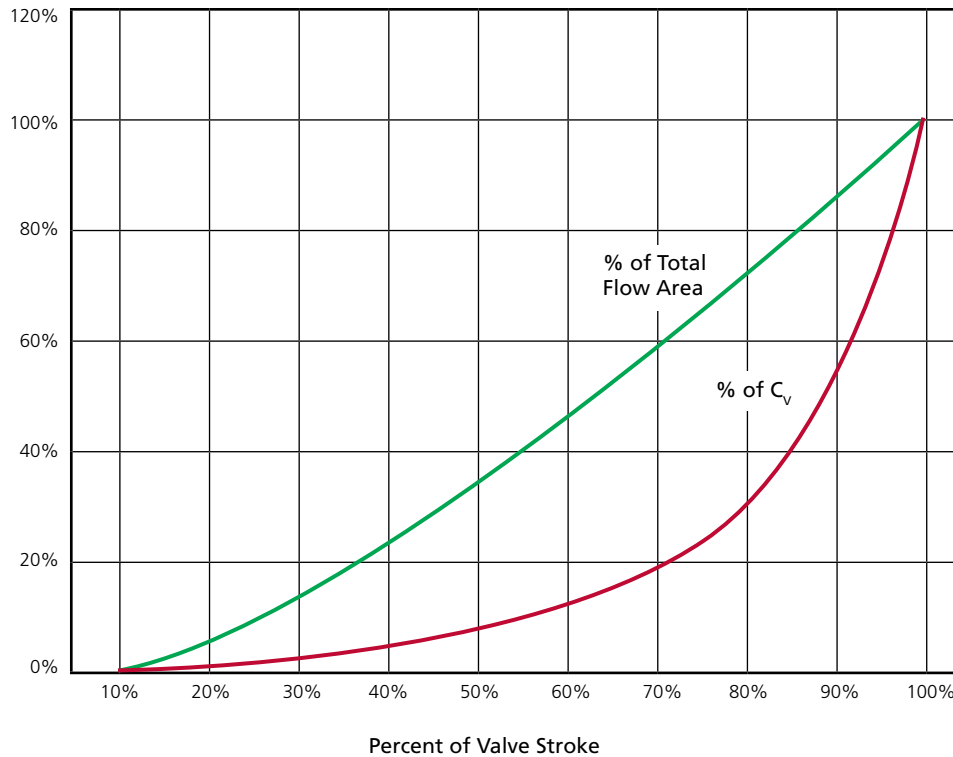

CAMSERV™ Aftermarket Services for Valves and Actuation

WE BUILD IT. WE BACK IT.



Global Network and Local Support

Cameron is well-positioned to deliver total aftermarket support, quickly and efficiently, with unmatched OEM expertise. Our highly skilled engineers and technicians are available around the clock, seven days a week, to respond to customer queries, troubleshoot problems and offer reliable solutions.

Easily Accessible Parts and Spare Valves

- OEM spare valves, actuators and parts (including non-Cameron brands)
- Handling, storage, packaging and delivery
- Dedicated stocking program



Comprehensive Aftermarket Services Portfolio

- Parts and spare valves
- Repair
- Field services
- Preventative maintenance
- Equipment testing and diagnostics
- Remanufacturing
- Asset preservation
- Customer property management
- Training and recertification services
- Warranty



Customized Total Valve Care™ (TVC) Programs

Customized asset management plans that optimize uptime, availability and dedicated services.

- Engineering consultancy
- Site management
- Flange management
- Startup and commissioning
- Spare parts and asset management
- Operational support



Trademark Information

WKM is a registered trademark of Cameron. CAMSERV is a trademark of Cameron.

This document contains references to registered trademarks or product designations, which are not owned by Cameron.

Trademark	Owner
Inconel	INCO Nickel Sales, Inc.
Monel	INCO Alloys International, Inc
Stellite	Stoody Deloro Stellite, Inc.
Teflon	E.I. Dupont De Nemours & Company
Viton	Dupont Dow Elastomers L.L.C.



3250 Briarpark Drive, Suite 300

Houston, TX 77042

USA

Toll Free 1 800 323 9160

Learn more about WKM gate valves at:

www.c-a-m.com/WKM

WKM@c-a-m.com



HSE Policy Statement

At Cameron, we are committed ethically, financially and personally to a working environment where no one gets hurt and nothing gets harmed.